

Date: December 21, 2023

From: Wight & Company
2500 North Frontage Road
Darien, IL 60561

To: All Downers Grove SD58 Referendum Project bidders.

SUBJECT: ADDENDUM NO.1 TO THE BID DOCUMENTS FOR:

Elementary Schools Phase 1 ERATE RFP

Project No: 220281

This addendum forms a part of the bidding and contract documents and modifies the original bid documents with Title Sheets dated 12/18/2023. Acknowledge receipt of this addendum when providing bid price. FAILURE TO DO SO MAY SUBJECT BIDDER TO DISQUALIFICATION.

DRAWINGS

None

SPECIFICATIONS

1. Section 002113-1 – INSTRUCTION TO BIDDERS
 - a. REVISE Optional Pre-Bid Meeting/Site Visit: from Thursday, January 8th, to Monday January 8th.

This Addendum consists of TWO (1) written addendum pages, ZERO (0) sheets, for a total of EIGHTTEEN (18) pages.

END OF ADDENDUM

REQUEST FOR PROPOSALS & INSTRUCTIONS
December 18th, 2023

DOWNERS GROVE GRADE SCHOOL DISTRICT 58

ELEMENTARY PHASE 1 SCHOOLS:

E-RATE RFP

Henry Puffer, Highland, Hillcrest, & Whittier Elementary Schools

OWNER:

Downers Grove Grade School District 58
2300 Warrenville Road, Suite 200NE
Downers Grove, IL 60515

ARCHITECT:

Wight & Company
2500 North Frontage Road
Darien, IL 60561

CONSTRUCTION MANAGER:

Bulley & Andrews, LLC
1755 West Armitage
Chicago, IL 60622

NOTICE TO VENDORS

Responses will be received by Downers Grove Grade School District 58 for the following project:

**E-Rate RFP: Elementary Phase 1 Schools
Henry Puffer, Highland, Hillcrest, & Whittier Elementary Schools**

Responses will be received until **12:00 p.m. local time on Tuesday, January 23rd, 2024** via email to jeichmiller@dg58.org.
Subject line: **Elementary Phase 1 School – E-Rate RFP**

All submissions must be submitted in accordance with the instructions contained in the Documents for the project. Security in the form of a bid bond in an amount equal to ten percent (10%) of the base bid amount shall be submitted with your submission. The bond shall be payable to the **Downers Grove Grade School District 58, 2300 Warrenville Road, Suite 200NE, Downers Grove, IL 60515**. All documents and information required by the instructions contained in the Documents for the project shall be completely submitted. **Incomplete, late or non-conforming responses will not be accepted.**

No submissions shall be withdrawn, cancelled or modified after the time for opening of bids without the Board's consent for a period of sixty (60) days after the scheduled time of bid opening.

The Documents for the project (which include the instructions for the project and other related documents) will be available by 5:00pm local time on Monday, December 18th, 2023 and may viewed/downloaded online without cost at the District's website. If required/desired all prints of the related documents are the responsibility of the contractor submitting on the project.

The Board reserves the right to reject any or all proposals or parts thereof, or waive any irregularities or informalities.

Any such decision shall be considered final.

A non-mandatory information session followed by site visits will take place starting at **2:30pm Central Time on Thursday, January 8th, 2024 at Henry Puffer Elementary School located at 2220 Haddow Ave, Downers Grove, IL 60515**. Interested parties may inspect the existing conditions and site logistics.

The successful firm shall comply with the provisions of the Illinois *Prevailing Wage Act*, specifically including the payment of the applicable prevailing wages to all laborers, workers, and mechanics performing work under the contract. If during the time period of the work, the prevailing wage rates change, the contractor shall be responsible for additional costs without any change to the contract amount. All bidders must comply with the Illinois Statutory requirements regarding labor, including Equal Employment Opportunity Laws.

For additional information on the project, contact James Eichmiller at jeichmiller@dg58.org or 630-719-2768. All questions must be received in writing, or via email, until 12:00 p.m. Monday January 12th, 2024.

Project:	DOWNERS GROVE GRADE SCHOOL DISTRICT 58 ELEMENTARY PHASE 1 SCHOOLS
Owner:	Downers Grove Grade School District 58
Architect/Engineer:	Wight & Company
Document Issue Date:	December 18th, 2023
Optional Pre-Bid Meeting/ Site Visit:	Monday (<i>Addendum 1</i>), January 8th, 2024 @ 2:30pm – at Henry Puffer Elementary School located at 2220 Haddow Ave, Downers Grove, IL 60515.
Bids Received:	Tuesday, January 23rd, 2024 at 12:00 p.m. Downers Grove Grade School District 58 District Service Center 1860 63rd Street Downers Grove, IL 60516 Assist. Sup. Technology & Learning: James Eichmiller Phone: 630-719-2768 Email: jeichmiller@dg58.org
Project Architect:	Wight & Company 2500 N. Frontage Road Darien, IL 60561 Senior Project Manager: Amy Tiberi Phone: 630-739-6494 Email: atiberi@wightco.com
Construction Manager:	Bulley & Andrews, LLC 1755 W. Armitage Ave. Chicago, IL 60622 Senior Project Manager: Ben Steele Phone: 630-220-3330 Email: bsteele@bulley.com

E-Rate RFP: PROPOSAL FORM

DOWNERS GROVE GRADE SCHOOL DISTRICT 58 ELEMENTARY PHASE 1 SCHOOLS:

Henry Puffer Elementary School

Highland Elementary School

Hillcrest Elementary School

Whittier Elementary School

Proposals are to be emailed to jeichmiller@dg58.org

CONTRACTOR INFORMATION

Company Name: _____

DATE:

Contact Name: _____

Address: _____

City, State, Zip Code: _____

Contact email: _____

Contact phone: _____

DOWNERS GROVE GRADE SCHOOL DISTRICT 58 ELEMENTARY PHASE 1 SCHOOLS – E-Rate RFP

E-Rate RFP: Elementary Phase 1 Schools

Henry Puffer, Highland, Hillcrest, & Whittier Elementary Schools

BASE BID

All work associated with “this subcontractor’s scope” as identified within the documents. Owner reserves the right to determine the responsible award based on the Base Bid for each school separately or combined.

BASE BID HENRY PUFFER ELEMENTARY SCHOOL \$ _____

BASE BID HIGHLAND ELEMENTARY SCHOOL \$ _____

BASE BID HILLCREST ELEMENTARY SCHOOL \$ _____

BASE BID WHITTIER ELEMENTARY SCHOOL \$ _____

BREAK OUT PRICING

Please note that breakout pricing is being requested for accounting purposes only. Breakout pricing will not be utilized to determine most responsible proposal.

Downer Grove SD 58
Elementary Schools Phase 1

220281

PA/CLOCK AT HENRY PUFFER ELEMENTARY SCHOOL \$ _____
PHONE AT HENRY PUFFER ELEMENTARY SCHOOL \$ _____

PA/CLOCK AT HIGHLAND ELEMENTARY SCHOOL \$ _____
PHONE AT HIGHLAND ELEMENTARY SCHOOL \$ _____

PA/CLOCK AT HILLCREST ELEMENTARY SCHOOL \$ _____
PHONE AT HILLCREST ELEMENTARY SCHOOL \$ _____

PA/CLOCK AT WHITTIER ELEMENTARY SCHOOL \$ _____
PHONE AT WHITTIER ELEMENTARY SCHOOL \$ _____

UNIT PRICES

Provide WAP ceiling data location consisting of two (2) category 6a 8p8c (rj45) jacks and two (2) category 6a cables to support customer provided and CIC installed wireless access points. CIC to furnish and install two (2) category 6a cables and two (2) category 6a 8p8c (rj45) jacks with a 25-foot service loop at this location. CIC to furnish and install two (2) category 6a cables and two (2) category 6a 8p8c (rj45) modular plugs at end of the 25-foot service loop coil. Refer to the specifications for cable and jack requirements.

\$ _____

Provide new data location. CIC to furnish and install one (1) category 6 cable and one (1) category 6 8p8c (rj45) jack. Refer to the Specification drawing for cable and jack requirements. CIC to coordinate Faceplate finish and height with architects.

\$ _____

ALTERNATES

All work associated with “this subcontractor’s scope” as identified within the documents

Alternate proposals are required by the Contract Documents or addenda thereto, vendor must complete the applicable alternate below by indicating how the alternate would increase their Base Bid. If the alternate below does not affect the cost of the bid, indicate by “\$0.00”. Alternates are not ordered for preference of acceptance. Owner reserves right to accept alternates as desired . Acceptance of alternate bids does not affect the project completion date.

ADD ALTERNATE 1a \$ _____
Henry Puffer Elementary School: WAP Locations (*as indicated on drawings*)

ADD ALTERNATE 1b \$ _____
Henry Puffer Elementary School: Projector Locations (*as indicated on drawings*)

ADD ALTERNATE 2a \$ _____
 Highland Elementary School: WAP Locations *(as indicated on drawings)*

ADD ALTERNATE 2b \$ _____
 Highland Elementary School: Projector Locations *(as indicated on drawings)*

ADD ALTERNATE 3a \$ _____
 Hillcrest Elementary School: WAP Locations *(as indicated on drawings)*

ADD ALTERNATE 3b \$ _____
 Hillcrest Elementary School: Projector Locations *(as indicated on drawings)*

ADD ALTERNATE 4a \$ _____
 Whittier Elementary School: WAP Locations *(as indicated on drawings)*

ADD ALTERNATE 4b \$ _____
 Whittier Elementary School: Projector Locations *(as indicated on drawings)*

SCHEDULE & COORDINATION

Indicate compliance by placing a X or checkmark in each row in space provided

<u>E-Rate contractor understands the scope of work included in the solicitation is party to and included within a larger renovation project at the noted sites within the District.</u>	
<u>E-Rate contractor understands that coordination with other entities employed by the District will be required to facilitate this work - this will include architecture, engineering, construction management, and installing contractors.</u>	
<u>E-Rate contractor acknowledges that other contractors will be occupying spaces of proposed improvements simultaneously, and is responsible for coordinating its work with other trades.</u>	
<u>E-Rate contractor acknowledges the schedule for this work will occur during Summer 2024 months, planned between June 17th and July 12th, 2024. These dates are subject to change based on coordination with the District architect, engineer, construction manager and installing contractors.</u>	
<u>E-Rate contractor acknowledges that the schedule at each school operates independently from the others.</u>	
<u>E- Rate contractor will allocate manpower accordingly to accommodate the schedule and scope of work in multiple areas and/or schools. This contractor is expected to provide multiple crews to work in multiple areas at the same time to maintain the individual school and overall district project schedule.</u>	
<u>Subcontractor dedicated onsite foreman shall provide at their own expense any necessary technology tools such as iPad or Tablets for collaborative software programs</u>	

<u>such as Procore, Bluebeam, dropbox, plan grid, CMIC, Bim 360, etc.. that are being implemented on the project</u>	
----------------------------------------------------------------------------------------------------------------------	--

BIDS SHALL BE ACCOMPANIED BY BID BOND OR SECURITY IN AN AMOUNT NOT LESS THAN TEN PERCENT (10%) OF THE AMOUNT OF THE TOTAL BID. ALL SIGNED AFFIDAVITS TO BE PROVIDED WITH BID SUBMISSION

Any and all exceptions to these specifications MUST be clearly and completely indicated on the proposal sheet.

Attach additional pages if necessary. **NOTE TO BIDDERS:** Please be advised that any exceptions to these specifications may cause your bid to be disqualified. Submit bids by SEALED BID ONLY.

THE SECTION BELOW MUST BE COMPLETED IN FULL AND SIGNED

The undersigned hereby certifies that they have read and understand the contents of this solicitation and agree to furnish at the prices shown any or all of the items above, subject to all instructions, conditions, specifications and attachments hereto. Failure to have read all the provisions of this solicitation shall not be cause to alter any resulting contract or to accept any request for additional compensation. By signing this document, the bidder hereby certifies that they are not barred from bidding on this contract as a result of a violation of either Section 33E-3 or 33E-4 of the Illinois Criminal Code of 2012, as amended.

In addition, the under signed hereby certifies they have received, reviewed and understand the contents of the following documents that will become a part of the Subcontract Agreement:

- Complete Set of, "E-Rate RFP" Plans Dated 12/18/2023 and Project Manual with Selected Specifications Dated 12/18/2023 for Downers Grove Grade School District 58 Additions and Renovations
- Addenda:
 - No. _____, dated _____
 - No. _____, dated _____
 - No. _____, dated _____
- 470 form and narrative _____
- Instruction to Bidders dated **December 18th, 2023**

Authorized Signature: _____

Company Name: _____

Typed/Printed Name: _____

Date: _____

Title: _____

Telephone

Number: _____

E-mail _____

Fax

Number: _____

- The vendor must include their SPIN number on the cost proposal.
- Alternative bids or substitutions are allowed but must be clearly identified and detailed as different from the specification.
- Subcontractors are permitted with permission. Vendors must identify the subcontractor and the Downers Grove School District 58 has the right to reject a subcontractor.
- Vendors will bid separately and allocate out all non-E-rate eligible hardware and software.
- Vendors are required to have a Service Center and Service Personnel within the state of Illinois.
- Vendors must have at least three (3) school references of the same size or larger than the Downers Grove School District 58
- Vendor must possess and prove/certify that it has certifications on all hardware and software included in the bid.
- The Downers Grove School District 58 reserves the right to reject all proposals.
- This bid is based on Downers Grove School District 58 Board of Education approval and does not bind the Downers Grove School District 58 into a contract or purchase.
- For each location bids/proposals are required to have separate costs by line item and must list the manufacturer's make and model/SKU number, quantity, unit cost and extended cost.
- If applicable, the vendor is to specify freight assurance fees, shipping charges, taxes, surcharges and contingency fees for eligible equipment.
 - E-Rate contractor understands the scope of work included in the solicitation is party to and included within a larger renovation project at the noted sites within the District..
 - E-Rate contractor understands that coordination with other entities employed by the District will be required to facilitate this work - this will include architecture, engineering, construction management, and installing contractors.
 - E-Rate contractor acknowledges that other contractors will be occupying spaces of proposed improvements simultaneously, and is responsible for coordinating its work with other trades.
 - E-Rate contractor acknowledges the schedule for this work will occur during Summer 2024 months, **planned between** June 17th and July 12th, 2024. **These dates are subject to change based on coordination with the District architect, engineer, construction manager and installing contractors.**
 - E-Rate contractor acknowledges that the schedule at each school operates independently from the others. E-Rate contractor will allocate manpower accordingly to accommodate the schedule and scope of work in multiple areas **and/or schools**. This contractor is expected to provide multiple crews to work in multiple areas at the same time to maintain the individual school and overall district project schedule.

Proposal Criteria: The Downers Grove School District 58 is seeking proposals from the most qualified vendors of Wiring system Infrastructure that can provide a very cost-effective price (#1 criteria), excellent reliability and proven, fast, effective service, (previous Downers Grove School District 58 experience is a plus), school district experience, equipment market share and references, and its point of presence within the Chicagoland area. The Downers Grove School District 58 will carefully weigh these criteria and decide based on the E-rate Decision Matrix as a basis.

E-rate Participation: It is imperative that the successful vendor participate in good standing with the Federal E-rate program and that the vendor can show at least three E-rate examples or references in the state of Illinois.

Please provide your Service Provider Identification Number (SPIN) _____.

Vendor must certify that it will annually certify itself with the E-rate program, via a Service Provider Annual Certification, or SPAC, so that the Downers Grove School District 58 will be assured that it will be able to collect from the program.

References: Preference will be given to vendors that have at least three (3) references in the state of Illinois.

Vendor Description: Please provide an overview of your company with the number of support personnel, annual sales, and school district success stories.

E-RATE FINANCIAL SUMMARY SECTION

HENRY PUFFER ELEMENTARY SCHOOL

Cost of Fiber Cabling and of Fiber Installation	\$ _____
Purchase of Fiber Installation	\$ _____
Cost of Cat 6a Cabling and 6a Installation	\$ _____
Cost of Cat 6a Installation	\$ _____
Purchase of Miscellaneous and Move of Equipment as specified	\$ _____
TOTAL E-RATE INSTALLATION AND CONFIGURATION COSTS	\$ _____

ONE-TIME COSTS

HIGHLAND ELEMENTARY SCHOOL

Cost of Fiber Cabling and of Fiber Installation	\$ _____
Purchase of Fiber Installation	\$ _____
Cost of Cat 6a Cabling and 6a Installation	\$ _____
Cost of Cat 6a Installation	\$ _____
Purchase of Miscellaneous and Move of Equipment as specified	\$ _____
TOTAL E-RATE INSTALLATION AND CONFIGURATION COSTS	\$ _____

ONE-TIME COSTS

HILLCREST ELEMENTARY SCHOOL

Cost of Fiber Cabling and of Fiber Installation	\$ _____
Purchase of Fiber Installation	\$ _____
Cost of Cat 6a Cabling and 6a Installation	\$ _____
Cost of Cat 6a Installation	\$ _____
Purchase of Miscellaneous and Move of Equipment as specified	\$ _____
TOTAL E-RATE INSTALLATION AND CONFIGURATION COSTS	\$ _____

ONE-TIME COSTS

WHITTIER ELEMENTARY SCHOOL

Cost of Fiber Cabling and of Fiber Installation	\$ _____
Purchase of Fiber Installation	\$ _____
Cost of Cat 6a Cabling and 6a Installation	\$ _____
Cost of Cat 6a Installation	\$ _____
Purchase of Miscellaneous and Move of Equipment as specified	\$ _____
TOTAL E-RATE INSTALLATION AND CONFIGURATION COSTS	\$ _____

ONE-TIME COSTS

GENERAL TERMS AND CONDITIONS

1. INTENT

- 1.1. The intention is to purchase services for construction of the new District 58 Additions and Renovations work.
- 1.2. The bidders should refer to and consider the following documents in preparing their bids:
 - 1.2.1. Complete Set of, "BID GROUP 2" Plans Dated 10/30/2023 and Project Manual with Selected Specifications Dated 10/30/2023 for Downers Grove Grade School District 58 Additions and Renovations
 - 1.2.2. All Associate Addendums
 - 1.2.3. Instruction to Bidders dated 12/18/2023

2. PREVAILING WAGE ACT

- 2.1. All laborers, workers and mechanics performing Work under the Contract shall not be paid less than the prevailing wage as found by the Illinois Department of Labor, and that Contractor and all Subcontractors shall in all other respects comply with the Prevailing Wage Act in carrying out Work under the Contract. If, during the course of Work under this Contract, the Department of Labor revises the prevailing rate of hourly wages to be paid under this contract, Contractor shall have the sole responsibility and duty to ensure that the revised prevailing rate of hourly wages is paid by Contractor and all Subcontractors to each worker to whom a revised rate is applicable. The prevailing rate of wages are revised by the Department of Labor and are available on the Department's official website. Revisions to the prevailing wage as set forth above shall not result in an increase in the Contract Sum. To the extent required by law, each Contractor and Subcontractor shall submit, on a monthly basis, a certified payroll to the Owner, evidencing the Contractor's and Subcontractor's compliance with the Prevailing Wage Act. Further all bonds required of the Contractor shall contain a provision as will guarantee the faithful performance of this prevailing wage clause.

3. AWARD

- 3.1. Bids shall be awarded to the responsible bidder, considering conformity with specifications, terms of delivery, and quality and serviceability, as determined by the Owner. Any such decision shall be considered final.
- 3.2. The bid price must be firm for at least sixty (60) calendar days after the latest date for submission of bids. The Owner reserves the right to reject any and all bids or any part thereof and to waive technicalities in the bidding.

4. TIME OF COMPLETION

- 4.1. Time is of the essence. Bidders should refer to and consider the Preliminary Project Schedule when preparing their bids.

5. BIDDER QUALIFICATIONS AND EVALUATION CRITERIA

- 5.1. All bidders must be qualified contractors and demonstrate the capability to provide services required in accordance with the bid specifications.

6. SECURITY GUARANTEE

- 6.1. Each bidder shall submit a Bid Bond in the amount of 10% of the Base Bid(s) to serve as a guarantee that the Contractor shall enter into a contract to perform the work identified herein, at the price bid. This security shall be retained by Downers Grove Grade School District 58 throughout the contract term to guarantee the Contractor's performance in accordance with the terms and conditions of the contract.
- 6.2. Any bid not complying with the Security requirement may be rejected as non-responsive.
- 6.3. A bidder may withdraw a bid at any time prior to the closing time for the receipt of bids. Any modification to a bid may be made only by substitution of another bid. However, no bidder shall withdraw, cancel or modify a bid for a period of sixty (60) calendar days after said closing time for the receipt of bids, nor shall the successful bidder withdraw, cancel or modify a bid after having been notified that said bid has been accepted by the Owner. Any bidder that withdraws, cancels or modifies a bid within said sixty (60) day period shall forfeit the Bid Bond.

7. CONTRACT BOND

7.1. A Payment and Performance Bond is required for this project in the amount of 100% of the contract sum.

8. ADDITIONAL INFORMATION

8.1. Should the bidder require additional information about this bid, submit questions via email to: jeichmiller@dg58.org. Questions are required no later noon than January 12th, 2024.

8.2. ANY and ALL changes to these specifications are valid only if they are included by written Addendum to All Bidders. No interpretation of the meaning of the plans, specifications or other contract documents will be made orally. Failure of any bidder to receive any such addendum or interpretation shall not relieve the bidder from obligation under this bid as submitted. All addenda so issued shall become part of the bid documents. Failure to request an interpretation constitutes a waiver to later claim that ambiguities or misunderstandings caused a bidder to improperly submit a bid.

9. DEFINITIONS

9.1. Base Bid is the sum stated in the Bid for which the Bidder offers to perform the Work described in the Bidding Documents as the base, to which Work may be added or from which Work may be deleted for sums stated in Alternate Bids or Unit Prices.

9.2. Alternate Bid is an amount stated in the Bid to be added to or deducted from the amount of the Base Bid if the corresponding change in the Work, as described in the Bidding Documents, is accepted.

9.3. Unit Price is an amount stated in the bid as a price per unit of measurement for materials, equipment or services, including all overhead and profit for a portion of the Work as described in the Bidding Documents. Bulley & Andrews may reject or negotiate any unit price considered excessive or unreasonable.

9.4. Owner is the person or entity identified as such in the Agreement and is referred to throughout the Contract Documents as if singular in number.

9.5. Architect is procured by the Owner who is lawfully licensed to practice architecture or an entity lawfully practicing architecture in the jurisdiction where the Project is located. That person or entity is identified as the Architect in the Agreement and is referred to throughout the Contract Documents as if singular in number.

9.6. Construction Manager is the person or entity identified as such in the Agreement and is referred to throughout the Contract Documents as if singular in number. The Construction Manager shall be lawfully licensed, if required in jurisdiction where the Project is located. The Construction Manager shall designate in writing a representative who shall have express authority to bind the Construction Manager/Contractor with respect to all matters related to the Contract. The term "Construction Manager" means the Construction Manager's authorized representative.

9.7. Contractor or Subcontractor is a person or entity who has a direct contract with the Construction Manager to perform a portion of the Work at the site. The term "subcontractor" is referred throughout the Contract Documents as if singular in number and means a Subcontractor or authorized representative of the Subcontractor. The term "Subcontractor" does not include a separate contractor or subcontractors of a separate contractor.

10. RESPONSIVE BID

10.1. A "Responsive Bid" is defined as a "bid which conforms in all material respects to the requirements set forth in the invitation for bids." Bidders are hereby notified that any exceptions to the requirements of this bid may be cause for rejection of the bid.

10.2. Bidders shall promptly notify Downers Grove Grade School District 58 of any ambiguity, inconsistency or error which they may discover upon examination of the bidding documents. Interpretations, corrections and

changes will be made by addendum. Each bidder shall ascertain prior to submitting a bid that all addenda have been received and acknowledged in the bid.

11. INSURANCE

11.1. The Contractor shall maintain for the duration of the contract insurance, which meets the Project Specification and Contract requirements.

12. CHANGE IN STATUS

12.1. The Contractor shall notify Construction Manager immediately of any change in its status resulting from any of the following: (a) vendor is acquired by another party; (b) vendor becomes insolvent; (c) vendor, voluntary or by operation law, becomes subject to the provisions of any chapter of the Bankruptcy Act; (d) vendor ceases to conduct its operations in normal course of business. Construction Manager shall have the option to terminate its contract with the vendor immediately on written notice based on any such change in status.

13. CHANGE ORDERS

13.1. In the event that a Change Order is required, the Contractor shall review the scope of work to be performed under the contract to suggest alternatives that can be implemented to offset the cost increase of any necessary changes without sacrificing the quality and/or scope of the contract specifications.

14. PRECEDENCE

14.1. In the event of inconsistencies within or between parts of the Contract Documents, or between the Contract Documents and applicable standards, codes, and ordinances, the Contractor shall provide the better quality or greater quantity of Work or comply with the more stringent requirements; either or both in accordance with the Architect's and Bulley & Andrew's interpretation.

15. VILLAGE CONTRACTOR'S LICENSE: Prior to commencing any work onsite, the awarded bidder must have a valid Village of Downers Grove Contractor's License on-file with the Development Department.

16. REPRESENTATIONS:

16.1. Each bidder warrants and represents that he or she has visited the site for the project and is familiar with the conditions under which the work will be performed.

16.2. Each bidder warrants and represents that it will furnish, with each request for payment, sworn statements and waivers of lien for itself and any of its subcontractors in form and substance satisfactory to Owner and such other forms as required by Owner, lender or title insurer, in order to assure an effective waiver of mechanic and materialmen liens in compliance with the laws of the State of Illinois.

Downers Grove Grade School District 58 Elementary Phase 1 Schools

CERTIFICATE OF COMPLIANCE AFFIDAVIT

THE UNDERSIGNED, BEING FIRST DULY SWORN ON OATH, DEPOSES AND STATES AS FOLLOWS:

1. That the undersigned has authority to make this certification on behalf of the bidder.

_____ Name of Company

2. That the undersigned has read the contents, in regard to disqualification of certain bidders which are contained on the following pages of the bid documents.
3. That the undersigned knows of his own knowledge that the bidder is not disqualified from submitting a bid under the aforesaid sections.

Authorized Signature _____

Type or Print Name _____

Title _____

SUBSCRIBED AND SWORN TO before me

this ____ day of _____, 20____.

Notary Public

Instructions: This is to be completely filled out and executed by the chief officer or the individual authorized to submit the certification.

Downers Grove Grade School District 58 Elementary Phase 1 Schools

ANTI-COLLUSION AFFIDAVIT AND BIDDER'S CERTIFICATION

THE UNDERSIGNED, BEING FIRST DULY SWORN ON OATH, DEPOSES AND STATES AS FOLLOWS:

1. That the undersigned has authority to make this certification on behalf of the bidder.

Name of Company

2. The party making the foregoing bid, that such bid is genuine and not collusive, or sham; that said bidder has not colluded, conspired, connived or agreed, directly or indirectly, with any person, to put in a sham bid or to refrain from participating and has not in any manner, directly or indirectly, sought by agreement or collusion, or communication or conference with any person; to fix the bid price element of said bid, or of that of any other bidder, or to secure any advantage against any other bidder or any person interested in the proposed contract.
3. The undersigned certifies that he is not barred from submitting a bid on this contract as a result of a conviction for the violation of State laws prohibiting bid-rigging or bid-rotating.

Authorized Signature _____

Type or Print Name _____

Title _____

SUBSCRIBED AND SWORN TO before me

this ____ day of _____, 20____.

Notary Public

Instructions: This is to be completely filled out and executed by the chief officer or the individual authorized to submit the certification.

Downers Grove Grade School District 58 Elementary Phase 1 Schools

(Vendors/Contractors with 25 or More Employees)

**CERTIFICATE OF COMPLIANCE WITH
ILLINOIS DRUG-FREE WORKPLACE ACT**

_____ (vendor/contractor), having 25 or more employees, does hereby certify pursuant to Section 3 of the *Illinois Drug-Free Workplace Act*, as amended (30 ILCS 580/3) that (he, she, it) shall provide a drug-free workplace for all employees engaged in the performance of work under the contract by complying with the requirements of the *Illinois Drug-Free Workplace Act*, as amended, (30 ILCS 580/1 et. seq.), and further certifies that (he, she, it) is not ineligible for award of this contract by reason of debarment for a violation of the *Illinois Drug-Free Workplace Act*, as amended (30 ILCS 580/1 et. seq.).

Vendor/Contractor

By: _____

Signature

Title

Date

Downer Grove Grade School District 58 Elementary Phase 1 Schools

(Individual Vendor/Contractor)

**CERTIFICATE OF COMPLIANCE WITH
ILLINOIS DRUG-FREE WORKPLACE ACT**

_____ (Individual Vendor/Contractor), does hereby certify pursuant to Section 4 of the *Illinois Drug-Free Workplace Act*, as amended (30 ILCS 580/4) that (he, she) will not engage in the unlawful manufacture, distribution, dispensation, possession, or use of a controlled substance in the performance of the contract and that (he, she) is not ineligible for award of this contract by reason of disbarment for a violation of the *Illinois Drug-Free Workplace Act*, as amended (30 ILCS 580/1 et. seq.).

Individual Vendor/Contractor

By: _____

Signature

Date

Downers Grove Grade School District 58 Elementary Phase 1 Schools

**CERTIFICATE REGARDING
SEXUAL HARASSMENT POLICY**

_____ (Vendor/Contractor), does hereby certify pursuant to Section 2-105 of the *Illinois Human Rights Act*, as amended (775 ILCS 5/2-105) that (he, she, it) has a written sexual harassment policy that includes, at the minimum, the following information: (1) the illegality of sexual harassment; (2) the definition of sexual harassment under State law; (3) a description of sexual harassment, utilizing examples; (4) an internal complaint process including penalties; (5) the legal recourse, investigative and complaint process available through the Department of Human Rights and Human Rights Commission; (6) directions on how to contact the Department of Human Rights and Human Rights Commission; and (7) protection against retaliation.

Name of Vendor/Contractor

By: _____
Signature

Title

Date



Project Manual For:

Downers Grove SD 58 Referendum Projects

Elementary Schools Phase 1

E-Rate RFP

December 18, 2023

**Prepared For
Downers Grove Grade School District 58
2300 Warrenville Rd.
Suite 200 NE
Downers Grove, Illinois 60515**



Prepared by:
Wight & Company
2500 North Frontage Road
Darien, IL 60561
630-969-7000
A/E Project No. 220281

SECTION 000110 - TABLE OF CONTENTS

SPECIFICATIONS FOR CONSTRUCTION

Project: Downers Grove SD 58 Referendum Projects
Elementary Schools Phase 1
Project Number: 220281

Owner: Board of Education
Downers Grove Grade School District 58
2300 Warrenville Road
Suite 200 NE
Downers Grove, Illinois 60515

Architect: Wight and Company
2500 North Frontage Road
Darien, Illinois 60561
630-969-7000

Division	Section Title
----------	---------------

SPECIFICATIONS GROUP

General Requirements Subgroup

DIVISION 00 – PROCUREMENT AND CONTRACTING REQUIREMENTS

002113 INVITATION TO BID & INSTRUCTIONS TO BIDDERS

DIVISION 01 - GENERAL REQUIREMENTS

012300 ALTERNATES
012500 SUBSTITUTION PROCEDURES
012519 SUBSTITUTION REQUEST FORM
012600 CONTRACT MODIFICATION PROCEDURES
013200 CONSTRUCTION PROGRESS DOCUMENTATION
013300 SUBMITTAL PROCEDURES
014000 QUALITY REQUIREMENTS
014200 REFERENCES
016000 PRODUCT REQUIREMENTS
017300 EXECUTION REQUIREMENTS
017700 CLOSEOUT PROCEDURES
017823 OPERATION AND MAINTENANCE DATA
017839 PROJECT RECORD DOCUMENTS
017900 DEMONSTRATION AND TRAINING
019113 GENERAL COMMISSIONING REQUIREMENTS

Facility Services Subgroup

DIVISION 27 - LOW VOLTAGE SYSTEMS

271000 COMMON WORK RESULTS FOR COMMUNICATIONS CABLING SYSTEMS
271100 BACKBONE COMMUNICATIONS CABLING

271200	HORIZONTAL COMMUNICATIONS CABLING
271300	INTERIOR COMMUNICATIONS PATHWAYS
271500	TELECOMMUNICATIONS ROOM REQUIREMENTS
271600	TELECOMMUNICATIONS GROUNDING REQUIREMENTS
271700	TESTING IDENTIFICATION AND ADMINISTRATION REQUIREMENTS
271800	CUTOVER AND TRAINING REQUIREMENTS
271900	SUPPORT AND WARRANTY REQUIREMENTS

END OF TABLE OF CONTENTS

REQUEST FOR PROPOSALS & INSTRUCTIONS
December 18th, 2023

DOWNERS GROVE GRADE SCHOOL DISTRICT 58

ELEMENTARY PHASE 1 SCHOOLS:

E-RATE RFP

Henry Puffer, Highland, Hillcrest, & Whittier Elementary Schools

OWNER:

Downers Grove Grade School District 58
2300 Warrenville Road, Suite 200NE
Downers Grove, IL 60515

ARCHITECT:

Wight & Company
2500 North Frontage Road
Darien, IL 60561

CONSTRUCTION MANAGER:

Bulley & Andrews, LLC
1755 West Armitage
Chicago, IL 60622

NOTICE TO VENDORS

Responses will be received by Downers Grove Grade School District 58 for the following project:

**E-Rate RFP: Elementary Phase 1 Schools
Henry Puffer, Highland, Hillcrest, & Whittier Elementary Schools**

Responses will be received until **12:00 p.m. local time on Tuesday, January 23rd, 2024** via email to jeichmiller@dg58.org.
Subject line: **Elementary Phase 1 School – E-Rate RFP**

All submissions must be submitted in accordance with the instructions contained in the Documents for the project. Security in the form of a bid bond in an amount equal to ten percent (10%) of the base bid amount shall be submitted with your submission. The bond shall be payable to the **Downers Grove Grade School District 58, 2300 Warrenville Road, Suite 200NE, Downers Grove, IL 60515**. All documents and information required by the instructions contained in the Documents for the project shall be completely submitted. **Incomplete, late or non-conforming responses will not be accepted.**

No submissions shall be withdrawn, cancelled or modified after the time for opening of bids without the Board's consent for a period of sixty (60) days after the scheduled time of bid opening.

The Documents for the project (which include the instructions for the project and other related documents) will be available by 5:00pm local time on Monday, December 18th, 2023 and may viewed/downloaded online without cost at the District's website. If required/desired all prints of the related documents are the responsibility of the contractor submitting on the project.

The Board reserves the right to reject any or all proposals or parts thereof, or waive any irregularities or informalities.

Any such decision shall be considered final.

A non-mandatory information session followed by site visits will take place starting at **2:30pm Central Time on Thursday, January 8th, 2024 at Henry Puffer Elementary School located at 2220 Haddow Ave, Downers Grove, IL 60515**. Interested parties may inspect the existing conditions and site logistics.

The successful firm shall comply with the provisions of the Illinois *Prevailing Wage Act*, specifically including the payment of the applicable prevailing wages to all laborers, workers, and mechanics performing work under the contract. If during the time period of the work, the prevailing wage rates change, the contractor shall be responsible for additional costs without any change to the contract amount. All bidders must comply with the Illinois Statutory requirements regarding labor, including Equal Employment Opportunity Laws.

For additional information on the project, contact James Eichmiller at jeichmiller@dg58.org or 630-719-2768. All questions must be received in writing, or via email, until 12:00 p.m. Monday January 12th, 2024.

Project:	DOWNERS GROVE GRADE SCHOOL DISTRICT 58 ELEMENTARY PHASE 1 SCHOOLS
Owner:	Downers Grove Grade School District 58
Architect/Engineer:	Wight & Company
Document Issue Date:	December 18th, 2023
Optional Pre-Bid Meeting/ Site Visit:	Thursday, January 8th, 2024 @ 2:30pm – at Henry Puffer Elementary School located at 2220 Hadow Ave, Downers Grove, IL 60515.
Bids Received:	Tuesday, January 23rd, 2024 at 12:00 p.m. Downers Grove Grade School District 58 District Service Center 1860 63rd Street Downers Grove, IL 60516 Assist. Sup. Technology & Learning: James Eichmiller Phone: 630-719-2768 Email: jeichmiller@dg58.org
Project Architect:	Wight & Company 2500 N. Frontage Road Darien, IL 60561 Senior Project Manager: Amy Tiberi Phone: 630-739-6494 Email: atiberi@wightco.com
Construction Manager:	Bulley & Andrews, LLC 1755 W. Armitage Ave. Chicago, IL 60622 Senior Project Manager: Ben Steele Phone: 630-220-3330 Email: bsteele@bulley.com

E-Rate RFP: PROPOSAL FORM

DOWNERS GROVE GRADE SCHOOL DISTRICT 58 ELEMENTARY PHASE 1 SCHOOLS:

Henry Puffer Elementary School

Highland Elementary School

Hillcrest Elementary School

Whittier Elementary School

Proposals are to be emailed to jeichmiller@dg58.org

CONTRACTOR INFORMATION

Company Name: _____

DATE:

Contact Name: _____

Address: _____

City, State, Zip Code: _____

Contact email: _____

Contact phone: _____

DOWNERS GROVE GRADE SCHOOL DISTRICT 58 ELEMENTARY PHASE 1 SCHOOLS – E-Rate RFP

E-Rate RFP: Elementary Phase 1 Schools

Henry Puffer, Highland, Hillcrest, & Whittier Elementary Schools

BASE BID

All work associated with “this subcontractor’s scope” as identified within the documents. Owner reserves the right to determine the responsible award based on the Base Bid for each school separately or combined.

BASE BID HENRY PUFFER ELEMENTARY SCHOOL \$ _____

BASE BID HIGHLAND ELEMENTARY SCHOOL \$ _____

BASE BID HILLCREST ELEMENTARY SCHOOL \$ _____

BASE BID WHITTIER ELEMENTARY SCHOOL \$ _____

BREAK OUT PRICING

Please note that breakout pricing is being requested for accounting purposes only. Breakout pricing will not be utilized to determine most responsible proposal.

Downer Grove SD 58
Elementary Schools Phase 1

220281

PA/CLOCK AT HENRY PUFFER ELEMENTARY SCHOOL \$ _____
PHONE AT HENRY PUFFER ELEMENTARY SCHOOL \$ _____

PA/CLOCK AT HIGHLAND ELEMENTARY SCHOOL \$ _____
PHONE AT HIGHLAND ELEMENTARY SCHOOL \$ _____

PA/CLOCK AT HILLCREST ELEMENTARY SCHOOL \$ _____
PHONE AT HILLCREST ELEMENTARY SCHOOL \$ _____

PA/CLOCK AT WHITTIER ELEMENTARY SCHOOL \$ _____
PHONE AT WHITTIER ELEMENTARY SCHOOL \$ _____

UNIT PRICES

Provide WAP ceiling data location consisting of two (2) category 6a 8p8c (rj45) jacks and two (2) category 6a cables to support customer provided and CIC installed wireless access points. CIC to furnish and install two (2) category 6a cables and two (2) category 6a 8p8c (rj45) jacks with a 25-foot service loop at this location. CIC to furnish and install two (2) category 6a cables and two (2) category 6a 8p8c (rj45) modular plugs at end of the 25-foot service loop coil. Refer to the specifications for cable and jack requirements.

\$ _____

Provide new data location. CIC to furnish and install one (1) category 6 cable and one (1) category 6 8p8c (rj45) jack. Refer to the Specification drawing for cable and jack requirements. CIC to coordinate Faceplate finish and height with architects.

\$ _____

ALTERNATES

All work associated with “this subcontractor’s scope” as identified within the documents

Alternate proposals are required by the Contract Documents or addenda thereto, vendor must complete the applicable alternate below by indicating how the alternate would increase their Base Bid. If the alternate below does not affect the cost of the bid, indicate by “\$0.00”. Alternates are not ordered for preference of acceptance. Owner reserves right to accept alternates as desired . Acceptance of alternate bids does not affect the project completion date.

ADD ALTERNATE 1a \$ _____
Henry Puffer Elementary School: WAP Locations (*as indicated on drawings*)

ADD ALTERNATE 1b \$ _____
Henry Puffer Elementary School: Projector Locations (*as indicated on drawings*)

ADD ALTERNATE 2a \$ _____
 Highland Elementary School: WAP Locations *(as indicated on drawings)*

ADD ALTERNATE 2b \$ _____
 Highland Elementary School: Projector Locations *(as indicated on drawings)*

ADD ALTERNATE 3a \$ _____
 Hillcrest Elementary School: WAP Locations *(as indicated on drawings)*

ADD ALTERNATE 3b \$ _____
 Hillcrest Elementary School: Projector Locations *(as indicated on drawings)*

ADD ALTERNATE 4a \$ _____
 Whittier Elementary School: WAP Locations *(as indicated on drawings)*

ADD ALTERNATE 4b \$ _____
 Whittier Elementary School: Projector Locations *(as indicated on drawings)*

SCHEDULE & COORDINATION

Indicate compliance by placing a X or checkmark in each row in space provided

<u>E-Rate contractor understands the scope of work included in the solicitation is party to and included within a larger renovation project at the noted sites within the District.</u>	
<u>E-Rate contractor understands that coordination with other entities employed by the District will be required to facilitate this work - this will include architecture, engineering, construction management, and installing contractors.</u>	
<u>E-Rate contractor acknowledges that other contractors will be occupying spaces of proposed improvements simultaneously, and is responsible for coordinating its work with other trades.</u>	
<u>E-Rate contractor acknowledges the schedule for this work will occur during Summer 2024 months, planned between June 17th and July 12th, 2024. These dates are subject to change based on coordination with the District architect, engineer, construction manager and installing contractors.</u>	
<u>E-Rate contractor acknowledges that the schedule at each school operates independently from the others.</u>	
<u>E- Rate contractor will allocate manpower accordingly to accommodate the schedule and scope of work in multiple areas and/or schools. This contractor is expected to provide multiple crews to work in multiple areas at the same time to maintain the individual school and overall district project schedule.</u>	
<u>Subcontractor dedicated onsite foreman shall provide at their own expense any necessary technology tools such as iPad or Tablets for collaborative software programs</u>	

<u>such as Procore, Bluebeam, dropbox, plan grid, CMIC, Bim 360, etc.. that are being implemented on the project</u>	
----------------------------------------------------------------------------------------------------------------------	--

BIDS SHALL BE ACCOMPANIED BY BID BOND OR SECURITY IN AN AMOUNT NOT LESS THAN TEN PERCENT (10%) OF THE AMOUNT OF THE TOTAL BID. ALL SIGNED AFFIDAVITS TO BE PROVIDED WITH BID SUBMISSION

Any and all exceptions to these specifications MUST be clearly and completely indicated on the proposal sheet.

Attach additional pages if necessary. **NOTE TO BIDDERS:** Please be advised that any exceptions to these specifications may cause your bid to be disqualified. Submit bids by SEALED BID ONLY.

THE SECTION BELOW MUST BE COMPLETED IN FULL AND SIGNED

The undersigned hereby certifies that they have read and understand the contents of this solicitation and agree to furnish at the prices shown any or all of the items above, subject to all instructions, conditions, specifications and attachments hereto. Failure to have read all the provisions of this solicitation shall not be cause to alter any resulting contract or to accept any request for additional compensation. By signing this document, the bidder hereby certifies that they are not barred from bidding on this contract as a result of a violation of either Section 33E-3 or 33E-4 of the Illinois Criminal Code of 2012, as amended.

In addition, the under signed hereby certifies they have received, reviewed and understand the contents of the following documents that will become a part of the Subcontract Agreement:

- Complete Set of, "E-Rate RFP" Plans Dated 12/18/2023 and Project Manual with Selected Specifications Dated 12/18/2023 for Downers Grove Grade School District 58 Additions and Renovations
- Addenda:
 - No. _____, dated _____
 - No. _____, dated _____
 - No. _____, dated _____
- 470 form and narrative _____
- Instruction to Bidders dated **December 18th, 2023**

Authorized Signature: _____

Company Name: _____

Typed/Printed Name: _____

Date: _____

Title: _____

Telephone

Number: _____

E-mail _____

Fax

Number: _____

- The vendor must include their SPIN number on the cost proposal.
- Alternative bids or substitutions are allowed but must be clearly identified and detailed as different from the specification.
- Subcontractors are permitted with permission. Vendors must identify the subcontractor and the Downers Grove School District 58 has the right to reject a subcontractor.
- Vendors will bid separately and allocate out all non-E-rate eligible hardware and software.
- Vendors are required to have a Service Center and Service Personnel within the state of Illinois.
- Vendors must have at least three (3) school references of the same size or larger than the Downers Grove School District 58
- Vendor must possess and prove/certify that it has certifications on all hardware and software included in the bid.
- The Downers Grove School District 58 reserves the right to reject all proposals.
- This bid is based on Downers Grove School District 58 Board of Education approval and does not bind the Downers Grove School District 58 into a contract or purchase.
- For each location bids/proposals are required to have separate costs by line item and must list the manufacturer's make and model/SKU number, quantity, unit cost and extended cost.
- If applicable, the vendor is to specify freight assurance fees, shipping charges, taxes, surcharges and contingency fees for eligible equipment.
 - E-Rate contractor understands the scope of work included in the solicitation is party to and included within a larger renovation project at the noted sites within the District..
 - E-Rate contractor understands that coordination with other entities employed by the District will be required to facilitate this work - this will include architecture, engineering, construction management, and installing contractors.
 - E-Rate contractor acknowledges that other contractors will be occupying spaces of proposed improvements simultaneously, and is responsible for coordinating its work with other trades.
 - E-Rate contractor acknowledges the schedule for this work will occur during Summer 2024 months, **planned between** June 17th and July 12th, 2024. **These dates are subject to change based on coordination with the District architect, engineer, construction manager and installing contractors.**
 - E-Rate contractor acknowledges that the schedule at each school operates independently from the others. E-Rate contractor will allocate manpower accordingly to accommodate the schedule and scope of work in multiple areas **and/or schools**. This contractor is expected to provide multiple crews to work in multiple areas at the same time to maintain the individual school and overall district project schedule.

Proposal Criteria: The Downers Grove School District 58 is seeking proposals from the most qualified vendors of Wiring system Infrastructure that can provide a very cost-effective price (#1 criteria), excellent reliability and proven, fast, effective service, (previous Downers Grove School District 58 experience is a plus), school district experience, equipment market share and references, and its point of presence within the Chicagoland area. The Downers Grove School District 58 will carefully weigh these criteria and decide based on the E-rate Decision Matrix as a basis.

E-rate Participation: It is imperative that the successful vendor participate in good standing with the Federal E-rate program and that the vendor can show at least three E-rate examples or references in the state of Illinois.

Please provide your Service Provider Identification Number (SPIN) _____.

Vendor must certify that it will annually certify itself with the E-rate program, via a Service Provider Annual Certification, or SPAC, so that the Downers Grove School District 58 will be assured that it will be able to collect from the program.

References: Preference will be given to vendors that have at least three (3) references in the state of Illinois.

Vendor Description: Please provide an overview of your company with the number of support personnel, annual sales, and school district success stories.

E-RATE FINANCIAL SUMMARY SECTION

HENRY PUFFER ELEMENTARY SCHOOL

Cost of Fiber Cabling and of Fiber Installation	\$ _____
Purchase of Fiber Installation	\$ _____
Cost of Cat 6a Cabling and 6a Installation	\$ _____
Cost of Cat 6a Installation	\$ _____
Purchase of Miscellaneous and Move of Equipment as specified	\$ _____
TOTAL E-RATE INSTALLATION AND CONFIGURATION COSTS	\$ _____

ONE-TIME COSTS

HIGHLAND ELEMENTARY SCHOOL

Cost of Fiber Cabling and of Fiber Installation	\$ _____
Purchase of Fiber Installation	\$ _____
Cost of Cat 6a Cabling and 6a Installation	\$ _____
Cost of Cat 6a Installation	\$ _____
Purchase of Miscellaneous and Move of Equipment as specified	\$ _____
TOTAL E-RATE INSTALLATION AND CONFIGURATION COSTS	\$ _____

ONE-TIME COSTS

HILLCREST ELEMENTARY SCHOOL

Cost of Fiber Cabling and of Fiber Installation	\$ _____
Purchase of Fiber Installation	\$ _____
Cost of Cat 6a Cabling and 6a Installation	\$ _____
Cost of Cat 6a Installation	\$ _____
Purchase of Miscellaneous and Move of Equipment as specified	\$ _____
TOTAL E-RATE INSTALLATION AND CONFIGURATION COSTS	\$ _____

ONE-TIME COSTS

WHITTIER ELEMENTARY SCHOOL

Cost of Fiber Cabling and of Fiber Installation	\$ _____
Purchase of Fiber Installation	\$ _____
Cost of Cat 6a Cabling and 6a Installation	\$ _____
Cost of Cat 6a Installation	\$ _____
Purchase of Miscellaneous and Move of Equipment as specified	\$ _____
TOTAL E-RATE INSTALLATION AND CONFIGURATION COSTS	\$ _____

ONE-TIME COSTS

GENERAL TERMS AND CONDITIONS

1. INTENT

- 1.1. The intention is to purchase services for construction of the new District 58 Additions and Renovations work.
- 1.2. The bidders should refer to and consider the following documents in preparing their bids:
 - 1.2.1. Complete Set of, "BID GROUP 2" Plans Dated 10/30/2023 and Project Manual with Selected Specifications Dated 10/30/2023 for Downers Grove Grade School District 58 Additions and Renovations
 - 1.2.2. All Associate Addendums
 - 1.2.3. Instruction to Bidders dated 12/18/2023

2. PREVAILING WAGE ACT

- 2.1. All laborers, workers and mechanics performing Work under the Contract shall not be paid less than the prevailing wage as found by the Illinois Department of Labor, and that Contractor and all Subcontractors shall in all other respects comply with the Prevailing Wage Act in carrying out Work under the Contract. If, during the course of Work under this Contract, the Department of Labor revises the prevailing rate of hourly wages to be paid under this contract, Contractor shall have the sole responsibility and duty to ensure that the revised prevailing rate of hourly wages is paid by Contractor and all Subcontractors to each worker to whom a revised rate is applicable. The prevailing rate of wages are revised by the Department of Labor and are available on the Department's official website. Revisions to the prevailing wage as set forth above shall not result in an increase in the Contract Sum. To the extent required by law, each Contractor and Subcontractor shall submit, on a monthly basis, a certified payroll to the Owner, evidencing the Contractor's and Subcontractor's compliance with the Prevailing Wage Act. Further all bonds required of the Contractor shall contain a provision as will guarantee the faithful performance of this prevailing wage clause.

3. AWARD

- 3.1. Bids shall be awarded to the responsible bidder, considering conformity with specifications, terms of delivery, and quality and serviceability, as determined by the Owner. Any such decision shall be considered final.
- 3.2. The bid price must be firm for at least sixty (60) calendar days after the latest date for submission of bids. The Owner reserves the right to reject any and all bids or any part thereof and to waive technicalities in the bidding.

4. TIME OF COMPLETION

- 4.1. Time is of the essence. Bidders should refer to and consider the Preliminary Project Schedule when preparing their bids.

5. BIDDER QUALIFICATIONS AND EVALUATION CRITERIA

- 5.1. All bidders must be qualified contractors and demonstrate the capability to provide services required in accordance with the bid specifications.

6. SECURITY GUARANTEE

- 6.1. Each bidder shall submit a Bid Bond in the amount of 10% of the Base Bid(s) to serve as a guarantee that the Contractor shall enter into a contract to perform the work identified herein, at the price bid. This security shall be retained by Downers Grove Grade School District 58 throughout the contract term to guarantee the Contractor's performance in accordance with the terms and conditions of the contract.
- 6.2. Any bid not complying with the Security requirement may be rejected as non-responsive.
- 6.3. A bidder may withdraw a bid at any time prior to the closing time for the receipt of bids. Any modification to a bid may be made only by substitution of another bid. However, no bidder shall withdraw, cancel or modify a bid for a period of sixty (60) calendar days after said closing time for the receipt of bids, nor shall the successful bidder withdraw, cancel or modify a bid after having been notified that said bid has been accepted by the Owner. Any bidder that withdraws, cancels or modifies a bid within said sixty (60) day period shall forfeit the Bid Bond.

7. CONTRACT BOND

7.1. A Payment and Performance Bond is required for this project in the amount of 100% of the contract sum.

8. ADDITIONAL INFORMATION

8.1. Should the bidder require additional information about this bid, submit questions via email to: jeichmiller@dg58.org. Questions are required no later noon than January 12th, 2024.

8.2. ANY and ALL changes to these specifications are valid only if they are included by written Addendum to All Bidders. No interpretation of the meaning of the plans, specifications or other contract documents will be made orally. Failure of any bidder to receive any such addendum or interpretation shall not relieve the bidder from obligation under this bid as submitted. All addenda so issued shall become part of the bid documents. Failure to request an interpretation constitutes a waiver to later claim that ambiguities or misunderstandings caused a bidder to improperly submit a bid.

9. DEFINITIONS

9.1. Base Bid is the sum stated in the Bid for which the Bidder offers to perform the Work described in the Bidding Documents as the base, to which Work may be added or from which Work may be deleted for sums stated in Alternate Bids or Unit Prices.

9.2. Alternate Bid is an amount stated in the Bid to be added to or deducted from the amount of the Base Bid if the corresponding change in the Work, as described in the Bidding Documents, is accepted.

9.3. Unit Price is an amount stated in the bid as a price per unit of measurement for materials, equipment or services, including all overhead and profit for a portion of the Work as described in the Bidding Documents. Bulley & Andrews may reject or negotiate any unit price considered excessive or unreasonable.

9.4. Owner is the person or entity identified as such in the Agreement and is referred to throughout the Contract Documents as if singular in number.

9.5. Architect is procured by the Owner who is lawfully licensed to practice architecture or an entity lawfully practicing architecture in the jurisdiction where the Project is located. That person or entity is identified as the Architect in the Agreement and is referred to throughout the Contract Documents as if singular in number.

9.6. Construction Manager is the person or entity identified as such in the Agreement and is referred to throughout the Contract Documents as if singular in number. The Construction Manager shall be lawfully licensed, if required in jurisdiction where the Project is located. The Construction Manager shall designate in writing a representative who shall have express authority to bind the Construction Manager/Contractor with respect to all matters related to the Contract. The term "Construction Manager" means the Construction Manager's authorized representative.

9.7. Contractor or Subcontractor is a person or entity who has a direct contract with the Construction Manager to perform a portion of the Work at the site. The term "subcontractor" is referred throughout the Contract Documents as if singular in number and means a Subcontractor or authorized representative of the Subcontractor. The term "Subcontractor" does not include a separate contractor or subcontractors of a separate contractor.

10. RESPONSIVE BID

10.1. A "Responsive Bid" is defined as a "bid which conforms in all material respects to the requirements set forth in the invitation for bids." Bidders are hereby notified that any exceptions to the requirements of this bid may be cause for rejection of the bid.

10.2. Bidders shall promptly notify Downers Grove Grade School District 58 of any ambiguity, inconsistency or error which they may discover upon examination of the bidding documents. Interpretations, corrections and

changes will be made by addendum. Each bidder shall ascertain prior to submitting a bid that all addenda have been received and acknowledged in the bid.

11. INSURANCE

11.1. The Contractor shall maintain for the duration of the contract insurance, which meets the Project Specification and Contract requirements.

12. CHANGE IN STATUS

12.1. The Contractor shall notify Construction Manager immediately of any change in its status resulting from any of the following: (a) vendor is acquired by another party; (b) vendor becomes insolvent; (c) vendor, voluntary or by operation law, becomes subject to the provisions of any chapter of the Bankruptcy Act; (d) vendor ceases to conduct its operations in normal course of business. Construction Manager shall have the option to terminate its contract with the vendor immediately on written notice based on any such change in status.

13. CHANGE ORDERS

13.1. In the event that a Change Order is required, the Contractor shall review the scope of work to be performed under the contract to suggest alternatives that can be implemented to offset the cost increase of any necessary changes without sacrificing the quality and/or scope of the contract specifications.

14. PRECEDENCE

14.1. In the event of inconsistencies within or between parts of the Contract Documents, or between the Contract Documents and applicable standards, codes, and ordinances, the Contractor shall provide the better quality or greater quantity of Work or comply with the more stringent requirements; either or both in accordance with the Architect's and Bulley & Andrew's interpretation.

15. VILLAGE CONTRACTOR'S LICENSE: Prior to commencing any work onsite, the awarded bidder must have a valid Village of Downers Grove Contractor's License on-file with the Development Department.

16. REPRESENTATIONS:

16.1. Each bidder warrants and represents that he or she has visited the site for the project and is familiar with the conditions under which the work will be performed.

16.2. Each bidder warrants and represents that it will furnish, with each request for payment, sworn statements and waivers of lien for itself and any of its subcontractors in form and substance satisfactory to Owner and such other forms as required by Owner, lender or title insurer, in order to assure an effective waiver of mechanic and materialmen liens in compliance with the laws of the State of Illinois.

Downers Grove Grade School District 58 Elementary Phase 1 Schools

CERTIFICATE OF COMPLIANCE AFFIDAVIT

THE UNDERSIGNED, BEING FIRST DULY SWORN ON OATH, DEPOSES AND STATES AS FOLLOWS:

1. That the undersigned has authority to make this certification on behalf of the bidder.

Name of Company

2. That the undersigned has read the contents, in regard to disqualification of certain bidders which are contained on the following pages of the bid documents.
3. That the undersigned knows of his own knowledge that the bidder is not disqualified from submitting a bid under the aforesaid sections.

Authorized Signature _____

Type or Print Name _____

Title _____

SUBSCRIBED AND SWORN TO before me

this ____ day of _____, 20____.

Notary Public

Instructions: This is to be completely filled out and executed by the chief officer or the individual authorized to submit the certification.

Downers Grove Grade School District 58 Elementary Phase 1 Schools

ANTI-COLLUSION AFFIDAVIT AND BIDDER'S CERTIFICATION

THE UNDERSIGNED, BEING FIRST DULY SWORN ON OATH, DEPOSES AND STATES AS FOLLOWS:

1. That the undersigned has authority to make this certification on behalf of the bidder.

Name of Company

2. The party making the foregoing bid, that such bid is genuine and not collusive, or sham; that said bidder has not colluded, conspired, connived or agreed, directly or indirectly, with any person, to put in a sham bid or to refrain from participating and has not in any manner, directly or indirectly, sought by agreement or collusion, or communication or conference with any person; to fix the bid price element of said bid, or of that of any other bidder, or to secure any advantage against any other bidder or any person interested in the proposed contract.
3. The undersigned certifies that he is not barred from submitting a bid on this contract as a result of a conviction for the violation of State laws prohibiting bid-rigging or bid-rotating.

Authorized Signature _____

Type or Print Name _____

Title _____

SUBSCRIBED AND SWORN TO before me

this ____ day of _____, 20____.

Notary Public

Instructions: This is to be completely filled out and executed by the chief officer or the individual authorized to submit the certification.

Downers Grove Grade School District 58 Elementary Phase 1 Schools

(Vendors/Contractors with 25 or More Employees)

**CERTIFICATE OF COMPLIANCE WITH
ILLINOIS DRUG-FREE WORKPLACE ACT**

_____ (vendor/contractor), having 25 or more employees, does hereby certify pursuant to Section 3 of the *Illinois Drug-Free Workplace Act*, as amended (30 ILCS 580/3) that (he, she, it) shall provide a drug-free workplace for all employees engaged in the performance of work under the contract by complying with the requirements of the *Illinois Drug-Free Workplace Act*, as amended, (30 ILCS 580/1 et. seq.), and further certifies that (he, she, it) is not ineligible for award of this contract by reason of debarment for a violation of the *Illinois Drug-Free Workplace Act*, as amended (30 ILCS 580/1 et. seq.).

Vendor/Contractor

By: _____

Signature

Title

Date

Downer Grove Grade School District 58 Elementary Phase 1 Schools

(Individual Vendor/Contractor)

**CERTIFICATE OF COMPLIANCE WITH
ILLINOIS DRUG-FREE WORKPLACE ACT**

_____ (Individual Vendor/Contractor), does hereby certify pursuant to Section 4 of the *Illinois Drug-Free Workplace Act*, as amended (30 ILCS 580/4) that (he, she) will not engage in the unlawful manufacture, distribution, dispensation, possession, or use of a controlled substance in the performance of the contract and that (he, she) is not ineligible for award of this contract by reason of disbarment for a violation of the *Illinois Drug-Free Workplace Act*, as amended (30 ILCS 580/1 et. seq.).

Individual Vendor/Contractor

By: _____

Signature

Date

Downers Grove Grade School District 58 Elementary Phase 1 Schools

**CERTIFICATE REGARDING
SEXUAL HARASSMENT POLICY**

_____ (Vendor/Contractor), does hereby certify pursuant to Section 2-105 of the *Illinois Human Rights Act*, as amended (775 ILCS 5/2-105) that (he, she, it) has a written sexual harassment policy that includes, at the minimum, the following information: (1) the illegality of sexual harassment; (2) the definition of sexual harassment under State law; (3) a description of sexual harassment, utilizing examples; (4) an internal complaint process including penalties; (5) the legal recourse, investigative and complaint process available through the Department of Human Rights and Human Rights Commission; (6) directions on how to contact the Department of Human Rights and Human Rights Commission; and (7) protection against retaliation.

Name of Vendor/Contractor

By: _____
Signature

Title

Date

SECTION 012300 - ALTERNATES

PART 1 - GENERAL

1.1 RELATED DOCUMENTS

- A. Drawings and general provisions of the Contract, including General and Supplementary Conditions and other Division 01 Specification Sections, apply to this Section.

1.2 SUMMARY

- A. Section includes administrative and procedural requirements for alternates.

1.3 DEFINITIONS

- A. Alternate: An amount proposed by bidders and stated on the Bid Form for certain work defined in the Bidding Requirements that may be added to or deducted from the base bid amount if Owner decides to accept a corresponding change either in the amount of construction to be completed or in the products, materials, equipment, systems, or installation methods described in the Contract Documents.
 - 1. Alternates described in this Section are part of the Work only if enumerated in the Agreement.
 - 2. The cost or credit for each alternate is the net addition to or deduction from the Contract Sum to incorporate alternate into the Work. No other adjustments are made to the Contract Sum.

1.4 PROCEDURES

- A. Coordination: Modify or adjust affected adjacent work as necessary to completely integrate work of the alternate into Project.
 - 1. Include as part of each alternate, miscellaneous devices, accessory objects, and similar items incidental to or required for a complete installation whether or not indicated as part of alternate.
 - 2. Include as part of each alternate, costs of related coordination, modification, or adjustment incidental to or required for a complete installation whether or not mentioned as part of the Alternate.
- B. Notification: Immediately following award of the Contract, notify each party involved, in writing, of the status of each alternate. Indicate if alternates have been accepted, rejected, or deferred for later consideration. Include a complete description of negotiated modifications to alternates.
- C. Execute accepted alternates under the same conditions as other work of the Contract.

- D. Schedule: A schedule of alternates is included at the end of this Section. Specification Sections referenced in schedule contain requirements for materials necessary to achieve the work described under each alternate.

PART 2 - PRODUCTS (Not Used)

PART 3 - EXECUTION

3.1 SCHEDULE OF ALTERNATES

- A. As indicated on Drawings.

END OF SECTION 012300

SECTION 012500 – SUBSTITUTION PROCEDURES

PART 1 - GENERAL

1.1 RELATED DOCUMENTS

- A. Drawings and general provisions of the Contract, including General and Supplementary Conditions and other Division 01 Specification Sections, apply to this Section.

1.2 SUMMARY

- A. Section includes administrative and procedural requirements for substitutions.
- B. Related Requirements:
 - 1. Division 01 Section "Alternates" for products selected under an alternate.
 - 2. Division 01 Section "Product Requirements" for requirements for submitting comparable product submittals for products by listed manufacturers.

1.3 DEFINITIONS

- A. Substitutions: Changes in products, materials, equipment, and methods of construction from those required by the Contract Documents and proposed by Contractor.
 - 1. Substitutions for Cause: Changes proposed by Contractor that are required due to changed Project conditions, such as unavailability of product, regulatory changes, or unavailability of required warranty terms.
 - 2. Substitutions for Convenience: Changes proposed by Contractor or Owner that are not required in order to meet other Project requirements but may offer advantage to Contractor or Owner.

1.4 ACTION SUBMITTALS

- A. Substitution Requests: Submit three copies of each request for consideration. Identify product or fabrication or installation method to be replaced. Include Specification Section number and title and Drawing numbers and titles.
 - 1. Substitution Request Form: Use facsimile of form provided in Project Manual.
 - 2. Documentation: Show compliance with requirements for substitutions and the following, as applicable:
 - a. Statement indicating why specified product or fabrication or installation cannot be provided, if applicable.
 - b. Coordination information, including a list of changes or modifications needed to other parts of the Work and to construction performed by Owner

- and separate contractors, that will be necessary to accommodate proposed substitution.
- c. Detailed comparison of significant qualities of proposed substitution with those of the Work specified. Include annotated copy of applicable specification section. Significant qualities may include attributes such as performance, weight, size, durability, visual effect, sustainable design characteristics, warranties, and specific features and requirements indicated. Indicate deviations, if any, from the Work specified.
 - d. Product Data, including drawings and descriptions of products and fabrication and installation procedures.
 - e. Samples, where applicable or requested.
 - f. Certificates and qualification data, where applicable or requested.
 - g. List of similar installations for completed projects with project names and addresses and names and addresses of architects and owners.
 - h. Material test reports from a qualified testing agency indicating and interpreting test results for compliance with requirements indicated.
 - i. Research reports evidencing compliance with building code in effect for Project, from ICC-ES.
 - j. Detailed comparison of Contractor's construction schedule using proposed substitution with products specified for the Work, including effect on the overall Contract Time. If specified product or method of construction cannot be provided within the Contract Time, include letter from manufacturer, on manufacturer's letterhead, stating date of receipt of purchase order, lack of availability, or delays in delivery.
 - k. Cost information, including a proposal of change, if any, in the Contract Sum.
 - l. Contractor's certification that proposed substitution complies with requirements in the Contract Documents except as indicated in substitution request, is compatible with related materials, and is appropriate for applications indicated.
 - m. Contractor's waiver of rights to additional payment or time that may subsequently become necessary because of failure of proposed substitution to produce indicated results.
3. Architect's Action: If necessary, Architect will request additional information or documentation for evaluation within seven days of receipt of a request for substitution. Architect will notify Contractor of acceptance or rejection of proposed substitution within 15 days of receipt of request, or seven days of receipt of additional information or documentation, whichever is later.
- a. Forms of Acceptance: Change Order, Construction Change Directive, or Architect's Supplemental Instructions for minor changes in the Work.
 - b. Use product specified if Architect does not issue a decision on use of a proposed substitution within time allocated.

1.5 QUALITY ASSURANCE

- A. Compatibility of Substitutions: Investigate and document compatibility of proposed substitution with related products and materials. Engage qualified testing agency to perform compatibility tests recommended by manufacturers.

1.6 PROCEDURES

- A. Coordination: Modify or adjust affected work as necessary to integrate work of the approved substitutions.

PART 2 - PRODUCTS

2.1 SUBSTITUTIONS

- A. Substitutions for Cause: Submit requests for substitution immediately upon discovery of need for change, but not later than 15 days prior to time required for preparation and review of related submittals.
 - 1. Conditions: Architect will consider Contractor's request for substitution when the following conditions are satisfied. If the following conditions are not satisfied, Architect will return requests without action, except to record noncompliance with these requirements:
 - a. Requested substitution is consistent with the Contract Documents and will produce indicated results.
 - b. Requested substitution provides sustainable design characteristics that specified product provided.
 - c. Substitution request is fully documented and properly submitted.
 - d. Requested substitution will not adversely affect Contractor's construction schedule.
 - e. Requested substitution has received necessary approvals of authorities having jurisdiction.
 - f. Requested substitution is compatible with other portions of the Work.
 - g. Requested substitution has been coordinated with other portions of the Work.
 - h. Requested substitution provides specified warranty.
 - i. If requested substitution involves more than one contractor, requested substitution has been coordinated with other portions of the Work, is uniform and consistent, is compatible with other products, and is acceptable to all contractors involved.
- B. Substitutions for Convenience: Not Allowed.

PART 3 - EXECUTION (Not Used)

END OF SECTION 012500

SECTION 012519 – SUBSTITUTION REQUEST FORM

Please refer to Section 016000 – Product Requirements. Substitution requests will not be considered without submittal of this completed form.

REFERENCE TO: Elementary Schools Phase 1 Project No. 220281

Having reviewed the requirements for the above Project, we hereby submit for consideration the following item in lieu of the specified item.

1. Section: _____ Specified Item: _____

2. Proposed Substitution: _____

3. Reason for Substitution: _____

4. Supporting Data Attached: _____

Yes _____ No _____ Technical data, including laboratory tests, if applicable.

Yes _____ No _____ Complete information on changes to Drawings/ Specifications that proposed substitution will require for proper installation.

Yes _____ No _____ Effects of substitution on drawing dimensions.

5. Yes _____ No _____ The undersigned will pay for changes to the building and systems design, including engineering and detailing costs caused by the requested substitution.

6. Yes _____ No _____ Does the substitution effect other trades? Describe:

7. Describe differences between proposed substitution and specified item:

8. Yes _____ No _____ Maintenance and services parts will be as readily available as for specified item.

9. Yes _____ No _____ Manufacturer's guarantees for the proposed and specified items are the same; describe differences:

The undersigned state that the function, appearance and quality of the proposed substitution are equivalent or superior to the specified item:

Submitted by:

Company: _____

For Use by Architect:

Address: _____

Accepted: _____ Accepted as noted: _____

Not Accepted _____ Received too late: _____

By: _____

By: _____

Date: _____

Date: _____

Telephone: _____

Remarks: _____

SECTION 012600 - CONTRACT MODIFICATION PROCEDURES

PART 1 - GENERAL

1.1 RELATED DOCUMENTS

- A. Drawings and general provisions of the Contract, including General and Supplementary Conditions and other Division 01 Specification Sections, apply to this Section.

1.2 SUMMARY

- A. Section specifies administrative and procedural requirements for handling and processing Contract modifications.
- B. Related Requirements:
 - 1. Division 01 Section "Substitution Procedures" for administrative procedures for handling requests for substitutions made after the Contract award.

1.3 MINOR CHANGES IN THE WORK

- A. Architect will issue supplemental instructions authorizing Minor Changes in the Work, not involving adjustment to the Contract Sum or the Contract Time, on AIA Document G710, "Architect's Supplemental Instructions."

1.4 PROPOSAL REQUESTS

- A. Owner-Initiated Proposal Requests: Architect will issue a detailed description of proposed changes in the Work that may require adjustment to the Contract Sum or the Contract Time. If necessary, the description will include supplemental or revised Drawings and Specifications.
 - 1. Proposal Requests issued by Architect are not instructions either to stop work in progress or to execute the proposed change.
 - 2. Within 10 days after receipt of Proposal Request, submit a detailed quotation of cost adjustments to the Contract Sum and the Contract Time necessary to execute the change.
 - a. Include a list of quantities of products required or eliminated and unit costs, with total amount of purchases and credits to be made. Provide a detailed labor, material and equipment breakdown.
 - b. Indicate applicable taxes, delivery charges, equipment rental, and amounts of trade discounts.

- c. Allow, for changes in the work other than that covered by Allowances, Alternates, or Unit Prices, an added percentage to compensate for the Contractor's profit margin, on the following basis:
 - 1) For work performed by the Contractor's own forces, 10 percent.
 - 2) For work performed by Subcontractors to the contractor, 5 percent.
 - d. Include an updated Contractor's Construction Schedule that indicates the effect of the change, including, but not limited to, changes in activity duration, start and finish times, and activity relationship.
- B. Contractor-Initiated Proposals: If latent or unforeseen conditions require modifications to the Contract, Contractor may propose changes by submitting a request for a change to Architect.
- 1. Include a statement outlining reasons for the change and the effect of the change on the Work. Provide a complete description of the proposed change. Indicate the effect of the proposed change on the Contract Sum and the Contract Time.
 - 2. Include a list of quantities of products required or eliminated and unit costs, with total amount of purchases and credits to be made. If requested, furnish survey data to substantiate quantities.
 - 3. Indicate applicable taxes, delivery charges, equipment rental, and amounts of trade discounts.
 - 4. Allow, for changes in the work other than that covered by Allowances, Alternates, or Unit Prices, an added percentage to compensate for the Contractor's profit margin, on the following basis:
 - a. For work performed by the Contractor's own forces, 10 percent.
 - b. For work performed by Subcontractors to the contractor, 5 percent.
 - 5. Include an updated Contractor's Construction Schedule that indicates the effect of the change, including, but not limited to, changes in activity duration, start and finish times, and activity relationship.
 - 6. Comply with requirements in Division 01 Section "Substitution Procedures" if the proposed change requires substitution of one product or system for product or system specified.

1.5 ADMINISTRATIVE CHANGE ORDERS

- A. Unit-Price Adjustment: See Division 01 Section "Unit Prices" for administrative procedures for preparation of Change Order Proposal for adjusting the Contract Sum to reflect measured scope of unit-price work.

1.6 CHANGE ORDER PROCEDURES

- A. On Owner's approval of a Proposal Request, Architect will issue a Change Order for signatures of Owner and Contractor.

1.7 CONSTRUCTION CHANGE DIRECTIVE

- A. Construction Change Directive: Architect may issue a Construction Change Directive on AIA Document G714. Construction Change Directive instructs Contractor to proceed with a change in the Work, for subsequent inclusion in a Change Order.
 - 1. Construction Change Directive contains a complete description of change in the Work. It also designates method to be followed to determine change in the Contract Sum or the Contract Time.
- B. Documentation: Maintain detailed records on a time and material basis of work required by the Construction Change Directive.
 - 1. After completion of change, submit an itemized account and supporting data necessary to substantiate cost and time adjustments to the Contract.

PART 2 - PRODUCTS (Not Used)

PART 3 - EXECUTION (Not Used)

END OF SECTION 012600

SECTION 013200 - CONSTRUCTION PROGRESS DOCUMENTATION

PART 1 - GENERAL

1.1 RELATED DOCUMENTS

- A. Drawings and general provisions of the Contract, including General and Supplementary Conditions and other Division 01 Specification Sections, apply to this Section.

1.2 SUMMARY

- A. Section includes administrative and procedural requirements for documenting the progress of construction during performance of the Work, including the following:

1. Startup construction schedule.
2. Contractor's construction schedule.
3. Construction schedule updating reports.
4. Daily construction reports.
5. Site condition reports.
6. Special reports.
7. Construction photographs.

- B. Related Requirements:

1. Division 01 Section "Submittal Procedures" for submitting schedules and reports.
2. Division 01 Section "Quality Requirements" for submitting a schedule of tests and inspections.

1.3 DEFINITIONS

- A. Activity: A discrete part of a project that can be identified for planning, scheduling, monitoring, and controlling the construction project. Activities included in a construction schedule consume time and resources.

- B. Event: The starting or ending point of an activity.

- C. Float: The measure of leeway in starting and completing an activity.

1. Float is not for the exclusive use or benefit of either Owner or Contractor, but is a jointly owned, expiring Project resource available to both parties as needed to meet schedule milestones and Contract completion date.
2. Free float is the amount of time an activity can be delayed without adversely affecting the early start of the following activity.
3. Total float is the measure of leeway in starting or completing an activity without adversely affecting the planned Project completion date.

- D. Major Area: A story of construction, a separate building, or a similar significant construction element.
- E. Milestone: A key or critical point in time for reference or measurement.

1.4 INFORMATIONAL SUBMITTALS

- A. Format for Submittals: Submit required submittals in the following format:
 - 1. Working electronic copy of schedule file, where indicated.
 - 2. PDF electronic file.
- B. Startup construction schedule.
 - 1. Approval of cost-loaded, startup construction schedule will not constitute approval of schedule of values for cost-loaded activities.
- C. Startup Network Diagram: Of size required to display entire network for entire construction period. Show logic ties for activities.
- D. Contractor's Construction Schedule: Initial schedule, of size required to display entire schedule for entire construction period.
 - 1. Submit a working electronic copy of schedule, using software indicated, and labeled to comply with requirements for submittals. Include type of schedule (initial or updated) and date on label.
- E. Construction Schedule Updating Reports: Submit with Applications for Payment.
- F. Daily Construction Reports: Submit at weekly intervals.
- G. Material Location Reports: Submit at weekly intervals.
- H. Site Condition Reports: Submit at time of discovery of differing conditions.
- I. Special Reports: Submit at time of unusual event.
- J. Construction Photographs: Submit digital photograph image files within three days of taking photographs.
 - 1. Digital Camera: Minimum sensor resolution of 8 megapixels.
 - 2. Format: Minimum 3200 by 2400 pixels, in unaltered original files, with same aspect ratio as the sensor, uncropped, date and time stamped, in folder named by date of photograph, accompanied by key plan file.
 - 3. Identification: Provide the following information with each image description in file metadata tag:
 - a. Name of Project.
 - b. Name and contact information for photographer.
 - c. Name of Architect.
 - d. Name of Contractor.

- e. Date photograph was taken.
- f. Description of vantage point, indicating location, direction (by compass point), and elevation or story of construction.
- g. Unique sequential identifier keyed to accompanying key plan.

1.5 COORDINATION

- A. Coordinate Contractor's construction schedule with the schedule of values, list of subcontracts, submittal schedule, progress reports, payment requests, and other required schedules and reports.
 1. Secure time commitments for performing critical elements of the Work from entities involved.
 2. Coordinate each construction activity in the network with other activities and schedule them in proper sequence.

PART 2 - PRODUCTS

2.1 CONTRACTOR'S CONSTRUCTION SCHEDULE, GENERAL

- A. Time Frame: Extend schedule from date established for commencement of the Work to date of final completion.
 1. Contract completion date shall not be changed by submission of a schedule that shows an early completion date, unless specifically authorized by Change Order.
- B. Activities: Treat each story or separate area as a separate numbered activity for each principal element of the Work. Comply with the following:
 1. Activity Duration: Define activities so no activity is longer than 20 days, unless specifically allowed by Architect.
 2. Procurement Activities: Include procurement process activities for long lead items and major items, requiring a cycle of more than 60 days, as separate activities in schedule. Procurement cycle activities include, but are not limited to, submittals, approvals, purchasing, fabrication, and delivery.
 3. Submittal Review Time: Include review and resubmittal times indicated in Division 01 Section "Submittal Procedures" in schedule. Coordinate submittal review times in Contractor's Construction Schedule with Submittals Schedule.
 4. Startup and Testing Time: Include not less than 15 days for startup and testing.
 5. Substantial Completion: Indicate completion in advance of date established for Substantial Completion, and allow time for Architect's administrative procedures necessary for certification of Substantial Completion.
 6. Punch List and Final Completion: Include not more than 30 days for completion of punch list items and final completion.

- C. Constraints: Include constraints and work restrictions indicated in the Contract Documents and as follows in schedule, and show how the sequence of the Work is affected.
1. Phasing: Arrange list of activities on schedule by phase.
 2. Work under More Than One Contract: Include a separate activity for each contract.
 3. Work by Owner: Include a separate activity for each portion of the Work performed by Owner.
 4. Products Ordered in Advance: Include a separate activity for each product. Include delivery date indicated in Division 01 Section "Summary." Delivery dates indicated stipulate the earliest possible delivery date.
 5. Owner-Furnished Products: Include a separate activity for each product. Include delivery date indicated in Division 01 Section "Summary." Delivery dates indicated stipulate the earliest possible delivery date.
 6. Work Restrictions: Show the effect of the following items on the schedule:
 - a. Coordination with existing construction.
 - b. Limitations of continued occupancies.
 - c. Uninterruptible services.
 - d. Partial occupancy before Substantial Completion.
 - e. Use of premises restrictions.
 - f. Provisions for future construction.
 - g. Seasonal variations.
 - h. Environmental control.
- D. Cost Correlation: At the head of schedule, provide a cost correlation line, indicating planned and actual costs. On the line, show dollar volume of the Work performed as of dates used for preparation of payment requests.
1. Refer to Division 01 Section "Payment Procedures" for cost reporting and payment procedures.

2.2 STARTUP CONSTRUCTION SCHEDULE

- A. Bar-Chart Schedule: Submit preliminary horizontal bar-chart-type construction schedule within seven days of date established for the Notice to Proceed.
- B. Preparation: Indicate each significant construction activity separately. Identify first workday of each week with a continuous vertical line. Outline significant construction activities for first 60 days of construction. Include skeleton diagram for the remainder of the Work and a cash requirement prediction based on indicated activities.

2.3 CONTRACTOR'S CONSTRUCTION SCHEDULE (GANTT CHART)

- A. Gantt-Chart Schedule: Submit a comprehensive, fully developed, horizontal Gantt-chart-type, Contractor's Construction Schedule within 30 days of date established for commencement of the Work. Base schedule on the Preliminary Construction Schedule and whatever updating and feedback was received since the start of Project.

- B. Preparation: Indicate each significant construction activity separately. Identify first workday of each week with a continuous vertical line.
 - 1. For construction activities that require 3 months or longer to complete, indicate an estimated completion percentage in 10 percent increments within time bar.

2.4 REPORTS

- A. Daily Construction Reports: Prepare a daily construction report recording the following information concerning events at Project site:
 - 1. List of subcontractors at Project site.
 - 2. List of separate contractors at Project site.
 - 3. Approximate count of personnel at Project site.
 - 4. Equipment at Project site.
 - 5. Material deliveries.
 - 6. High and low temperatures and general weather conditions, including presence of rain or snow.
 - 7. Accidents.
 - 8. Meetings and significant decisions.
 - 9. Unusual events (see special reports).
 - 10. Stoppages, delays, shortages, and losses.
 - 11. Meter readings and similar recordings.
 - 12. Emergency procedures.
 - 13. Orders and requests of authorities having jurisdiction.
 - 14. Change Orders received and implemented.
 - 15. Construction Change Directives received and implemented.
 - 16. Services connected and disconnected.
 - 17. Partial completions and occupancies.
 - 18. Substantial Completions authorized.
- B. Site Condition Reports: Immediately on discovery of a difference between site conditions and the Contract Documents, prepare and submit a detailed report. Submit with a Request for Information. Include a detailed description of the differing conditions, together with recommendations for changing the Contract Documents.

2.5 SPECIAL REPORTS

- A. General: Submit special reports directly to Owner within one day of an occurrence. Distribute copies of report to parties affected by the occurrence.
- B. Reporting Unusual Events: When an event of an unusual and significant nature occurs at Project site, whether or not related directly to the Work, prepare and submit a special report. List chain of events, persons participating, response by Contractor's personnel, evaluation of results or effects, and similar pertinent information. Advise Owner in advance when these events are known or predictable.

PART 3 - EXECUTION

3.1 CONTRACTOR'S CONSTRUCTION SCHEDULE

- A. Contractor's Construction Schedule Updating: At monthly intervals, update schedule to reflect actual construction progress and activities. Issue schedule one week before each regularly scheduled progress meeting.
 - 1. Revise schedule immediately after each meeting or other activity where revisions have been recognized or made. Issue updated schedule concurrently with the report of each such meeting.
 - 2. Include a report with updated schedule that indicates every change, including, but not limited to, changes in logic, durations, actual starts and finishes, and activity durations.
 - 3. As the Work progresses, indicate Actual Completion percentage for each activity.
- B. Distribution: Distribute copies of approved schedule to Architect, Owner, separate contractors, testing and inspecting agencies, and other parties identified by Contractor with a need-to-know schedule responsibility.
 - 1. Post copies in Project meeting rooms and temporary field offices.
 - 2. When revisions are made, distribute updated schedules to the same parties and post in the same locations. Delete parties from distribution when they have completed their assigned portion of the Work and are no longer involved in performance of construction activities.

3.2 CONSTRUCTION PHOTOGRAPHS

- A. General: Take photographs using the maximum range of depth of field, and that are in focus, to clearly show the Work. Photographs with blurry or out-of-focus areas will not be accepted.
 - 1. Maintain key plan with each set of construction photographs that identifies each photographic location.
- B. Digital Images: Submit digital images exactly as originally recorded in the digital camera, without alteration, manipulation, editing, or modifications using image-editing software.
 - 1. Date and Time: Include date and time in file name for each image.
 - 2. Field Office Images: Maintain one set of images accessible in the field office at Project site, available at all times for reference. Identify images in the same manner as those submitted to Architect.
- C. Preconstruction Photographs: Before starting construction, take photographs of Project site and surrounding properties from different vantage points, as directed by Architect. Show existing conditions adjacent to property.
 - 1. Flag construction limits before taking construction photographs.

2. Take 20 photographs to show existing conditions adjacent to property before starting the Work.
 3. Take 20 photographs of existing buildings either on or adjoining property to accurately record physical conditions at start of construction.
 4. Take additional photographs as required to record settlement or cracking of adjacent structures, pavements, and improvements.
- D. Periodic Construction Photographs: Take 20 photographs monthly, coinciding with cutoff date associated with each Application for Payment. Photographer shall select vantage points to best show status of construction and progress since last photographs were taken.
- E. Final Completion Construction Photographs: Take 20 photographs after date of Substantial Completion for submission as Project Record Documents. Architect will direct photographer for desired vantage points.
1. Do not include date stamp.

END OF SECTION 013200

SECTION 013300 – SUBMITTAL PROCEDURES

PART 1 - GENERAL

1.1 RELATED DOCUMENTS

- A. Drawings and general provisions of the Contract, including General and Supplementary Conditions and other Division 01 Specification Sections, apply to this Section.

1.2 SUMMARY

- A. Section includes requirements for the submittal schedule and administrative and procedural requirements for submitting Shop Drawings, Product Data, Samples, and other submittals.
- B. Related Requirements:
 - 1. Division 01 Section "Payment Procedures" for submitting Applications for Payment and the schedule of values.
 - 2. Division 01 Section "Construction Progress Documentation" for submitting schedules and reports, including Contractor's construction schedule.
 - 3. Division 01 Section "Operation and Maintenance Data" for submitting operation and maintenance manuals.
 - 4. Division 01 Section "Project Record Documents" for submitting record Drawings, record Specifications, and record Product Data.

1.3 DEFINITIONS

- A. Action Submittals: Written and graphic information and physical samples that require Architect's responsive action. Action submittals are those submittals indicated in individual Specification Sections as "action submittals."
- B. Informational Submittals: Written and graphic information and physical samples that do not require Architect's responsive action. Submittals may be rejected for not complying with requirements. Informational submittals are those submittals indicated in individual Specification Sections as "informational submittals."
- C. Portable Document Format (PDF): An open standard file format licensed by Adobe Systems used for representing documents in a device-independent and display resolution-independent fixed-layout document format.

1.4 ACTION SUBMITTALS

- A. Submittal Schedule: Submit a schedule of submittals, arranged in chronological order by dates required by construction schedule. Include time required for review, ordering,

manufacturing, fabrication, and delivery when establishing dates. Include additional time required for making corrections or revisions to submittals noted by Architect and additional time for handling and reviewing submittals required by those corrections.

1. Coordinate submittal schedule with list of subcontracts, the schedule of values, and Contractor's construction schedule.
2. Submit concurrently with the first complete submittal of Contractor's construction schedule.
 - a. Submit revised submittal schedule to reflect changes in current status and timing for submittals.
3. Format: Arrange the following information in a tabular format:
 - a. Scheduled date for first submittal.
 - b. Specification Section number and title.
 - c. Submittal category: Action; informational.
 - d. Name of subcontractor.
 - e. Description of the Work covered.
 - f. Scheduled date for Architect's final release or approval.
 - g. Scheduled date of fabrication.

1.5 SUBMITTAL ADMINISTRATIVE REQUIREMENTS

- A. Architect's Digital Data Files: Electronic digital data files of the Contract Drawings will be provided by Architect for Contractor's use in preparing submittals.
 1. Architect will furnish Contractor one set of digital data drawing files of the Contract Drawings for use in preparing Shop Drawings and Project record drawings.
 - a. Architect makes no representations as to the accuracy or completeness of digital data drawing files as they relate to the Contract Drawings.
 - b. Digital Drawing Software Program: The Contract Drawings are available in AutoCAD Architecture 2008.
 - c. Contractor shall execute a data licensing agreement in the form of Agreement included in Project Manual.
 - d. The following digital data files will be furnished for each appropriate discipline:
 - 1) Floor plans.
 - 2) Reflected ceiling plans.
- B. Coordination: Coordinate preparation and processing of submittals with performance of construction activities.
 1. Coordinate each submittal with fabrication, purchasing, testing, delivery, other submittals, and related activities that require sequential activity.

2. Submit all submittal items required for each Specification Section concurrently unless partial submittals for portions of the Work are indicated on approved submittal schedule.
 3. Submit action submittals and informational submittals required by the same Specification Section as separate packages under separate transmittals.
 4. Coordinate transmittal of different types of submittals for related parts of the Work so processing will not be delayed because of need to review submittals concurrently for coordination.
 - a. Architect reserves the right to withhold action on a submittal requiring coordination with other submittals until related submittals are received.
- C. Processing Time: Allow time for submittal review, including time for resubmittals, as follows. Time for review shall commence on Architect's receipt of submittal. No extension of the Contract Time will be authorized because of failure to transmit submittals enough in advance of the Work to permit processing, including resubmittals.
1. Initial Review: Allow 10 days for initial review of each submittal. Allow additional time if coordination with subsequent submittals is required. Architect will advise Contractor when a submittal being processed must be delayed for coordination.
 2. Intermediate Review: If intermediate submittal is necessary, process it in same manner as initial submittal.
 3. Resubmittal Review: Allow 10 days for review of each resubmittal.
- D. Electronic Submittals: Identify and incorporate information in each electronic submittal file as follows:
1. Assemble complete submittal package into a single indexed file incorporating submittal requirements of a single Specification Section and transmittal form with links enabling navigation to each item.
 2. Name file with submittal number or other unique identifier, including revision identifier.
 - a. File name shall use project identifier and Specification Section number followed by a decimal point and then a sequential number (e.g., LNHS-061000.01). Resubmittals shall include an alphabetic suffix after another decimal point (e.g., LNHS-061000.01.A).
 3. Provide means for insertion to permanently record Contractor's review and approval markings and action taken by Architect.
 4. Transmittal Form for Electronic Submittals: Use software-generated form from electronic project management software or electronic form acceptable to Architect, containing the following information:
 - a. Project name.
 - b. Date.
 - c. Name and address of Architect.
 - d. Name of Contractor.
 - e. Name of firm or entity that prepared submittal.
 - f. Names of subcontractor, manufacturer, and supplier.
 - g. Category and type of submittal.

- h. Submittal purpose and description.
 - i. Specification Section number and title.
 - j. Specification paragraph number or drawing designation and generic name for each of multiple items.
 - k. Drawing number and detail references, as appropriate.
 - l. Location(s) where product is to be installed, as appropriate.
 - m. Related physical samples submitted directly.
 - n. Indication of full or partial submittal.
 - o. Transmittal number, numbered consecutively.
 - p. Submittal and transmittal distribution record.
 - q. Other necessary identification.
 - r. Remarks.
- 5. Metadata: Include the following information as keywords in the electronic submittal file metadata:
 - a. Project name.
 - b. Number and title of appropriate Specification Section.
 - c. Manufacturer name.
 - d. Product name.
- E. Options: Identify options requiring selection by Architect.
- F. Deviations and Additional Information: On an attached separate sheet, prepared on Contractor's letterhead, record relevant information, requests for data, revisions other than those requested by Architect on previous submittals, and deviations from requirements in the Contract Documents, including minor variations and limitations. Include same identification information as related submittal.
- G. Resubmittals: Make resubmittals in same form and number of copies as initial submittal.
 - 1. Note date and content of previous submittal.
 - 2. Note date and content of revision in label or title block and clearly indicate extent of revision.
 - 3. Resubmit submittals until they are marked with approval notation from Architect's action stamp.
- H. Distribution: Furnish copies of final submittals to manufacturers, subcontractors, suppliers, fabricators, installers, authorities having jurisdiction, and others as necessary for performance of construction activities. Show distribution on transmittal forms.
- I. Use for Construction: Retain complete copies of submittals on Project site. Use only final action submittals that are marked with approval notation from Architect's action stamp.

PART 2 - PRODUCTS

2.1 SUBMITTAL PROCEDURES

- A. General Submittal Procedure Requirements: Prepare and submit submittals required by individual Specification Sections. Types of submittals are indicated in individual Specification Sections.
1. Submit electronic submittals via procore as PDF electronic files.
 - a. Architect will return annotated file. Annotate and retain one copy of file as an electronic Project record document file.
 - b. *Contractors dedicated onsite foreman shall provide at their own expense any necessary technology tools such as iPad or Tablets for collaborative software programs such as Procore, Bluebeam, dropbox, plan grid, CMIC, Bim 360, etc.. That are being implemented on the project.*
 2. Action Submittals: Submit three paper copies of each submittal unless otherwise indicated. Architect will return two copies.
 3. Informational Submittals: Submit two paper copies of each submittal unless otherwise indicated. Architect will not return copies.
 4. Certificates and Certifications Submittals: Provide a statement that includes signature of entity responsible for preparing certification. Certificates and certifications shall be signed by an officer or other individual authorized to sign documents on behalf of that entity.
 - a. Provide a digital signature with digital certificate on electronically submitted certificates and certifications where indicated.
- B. Product Data: Collect information into a single submittal for each element of construction and type of product or equipment.
1. If information must be specially prepared for submittal because standard published data are not suitable for use, submit as Shop Drawings, not as Product Data.
 2. Mark each copy of each submittal to show which products and options are applicable.
 3. Include the following information, as applicable:
 - a. Manufacturer's catalog cuts.
 - b. Manufacturer's product specifications.
 - c. Standard color charts.
 - d. Statement of compliance with specified referenced standards.
 - e. Testing by recognized testing agency.
 - f. Application of testing agency labels and seals.
 - g. Notation of coordination requirements.
 - h. Availability and delivery time information.

4. For equipment, include the following in addition to the above, as applicable:
 - a. Wiring diagrams showing factory-installed wiring.
 - b. Printed performance curves.
 - c. Operational range diagrams.
 - d. Clearances required to other construction, if not indicated on accompanying Shop Drawings.
 5. Submit Product Data before or concurrent with Samples.
 6. Submit Product Data in the following format:
 - a. PDF electronic file.
- C. Shop Drawings: Prepare Project-specific information, drawn accurately to scale. Do not base Shop Drawings on reproductions of the Contract Documents or standard printed data, unless submittal based on Architect's digital data drawing files is otherwise permitted.
1. Preparation: Fully illustrate requirements in the Contract Documents. Include the following information, as applicable:
 - a. Identification of products.
 - b. Schedules.
 - c. Compliance with specified standards.
 - d. Notation of coordination requirements.
 - e. Notation of dimensions established by field measurement.
 - f. Relationship and attachment to adjoining construction clearly indicated.
 - g. Seal and signature of professional engineer if specified.
 2. Sheet Size: Except for templates, patterns, and similar full-size drawings, submit Shop Drawings on sheets at least 8-1/2 by 11 inches, but no larger than 30 by 42 inches.
 3. Submit Shop Drawings in the following format:
 - a. PDF electronic file.
- D. Samples: Submit Samples for review of kind, color, pattern, and texture for a check of these characteristics with other elements and for a comparison of these characteristics between submittal and actual component as delivered and installed.
1. Transmit Samples that contain multiple, related components such as accessories together in one submittal package.
 2. Identification: Attach label on unexposed side of Samples that includes the following:
 - a. Generic description of Sample.
 - b. Product name and name of manufacturer.
 - c. Sample source.
 - d. Number and title of applicable Specification Section.
 - e. Specification paragraph number and generic name of each item.

3. For projects where electronic submittals are required, provide corresponding electronic submittal of Sample transmittal, digital image file illustrating Sample characteristics, and identification information for record.
 4. Disposition: Maintain sets of approved Samples at Project site, available for quality-control comparisons throughout the course of construction activity. Sample sets may be used to determine final acceptance of construction associated with each set.
 - a. Samples that may be incorporated into the Work are indicated in individual Specification Sections. Such Samples must be in an undamaged condition at time of use.
 - b. Samples not incorporated into the Work, or otherwise designated as Owner's property, are the property of Contractor.
 5. Samples for Initial Selection: Submit manufacturer's color charts consisting of units or sections of units showing the full range of colors, textures, and patterns available.
 - a. Number of Samples: Submit two full sets of available choices where color, pattern, texture, or similar characteristics are required to be selected from manufacturer's product line. Architect will return submittal with options selected.
 6. Samples for Verification: Submit full-size units or Samples of size indicated, prepared from same material to be used for the Work, cured and finished in manner specified, and physically identical with material or product proposed for use, and that show full range of color and texture variations expected. Samples include, but are not limited to, the following: partial sections of manufactured or fabricated components; small cuts or containers of materials; complete units of repetitively used materials; swatches showing color, texture, and pattern; color range sets; and components used for independent testing and inspection.
 - a. Number of Samples: Submit three sets of Samples. Architect will retain two Sample sets; remainder will be returned. Mark up and retain one returned Sample set as a project record sample.
 - 1) Submit a single Sample where assembly details, workmanship, fabrication techniques, connections, operation, and other similar characteristics are to be demonstrated.
 - 2) If variation in color, pattern, texture, or other characteristic is inherent in material or product represented by a Sample, submit at least three sets of paired units that show approximate limits of variations.
- E. Product Schedule: As required in individual Specification Sections, prepare a written summary indicating types of products required for the Work and their intended location. Include the following information in tabular form:
1. Type of product. Include unique identifier for each product indicated in the Contract Documents or assigned by Contractor if none is indicated.
 2. Manufacturer and product name, and model number if applicable.

3. Number and name of room or space.
 4. Location within room or space.
 5. Submit product schedule in the following format:
 - a. PDF electronic file.
- F. Coordination Drawing Submittals: Comply with requirements specified in Division 01 Section "Project Management and Coordination."
- G. Contractor's Construction Schedule: Comply with requirements specified in Division 01 Section "Construction Progress Documentation."
- H. Application for Payment and Schedule of Values: Comply with requirements specified in Division 01 Section "Payment Procedures."
- I. Test and Inspection Reports and Schedule of Tests and Inspections Submittals: Comply with requirements specified in Division 01 Section "Quality Requirements."
- J. Closeout Submittals and Maintenance Material Submittals: Comply with requirements specified in Division 01 Section "Closeout Procedures."
- K. Maintenance Data: Comply with requirements specified in Division 01 Section "Operation and Maintenance Data."
- L. Sustainable Design Submittals: Comply with requirements specified in Division 01 Section "Sustainable Design Requirements."
- M. Qualification Data: Prepare written information that demonstrates capabilities and experience of firm or person. Include lists of completed projects with project names and addresses, contact information of architects and owners, and other information specified.
- N. Installer Certificates: Submit written statements on manufacturer's letterhead certifying that Installer complies with requirements in the Contract Documents and, where required, is authorized by manufacturer for this specific Project.
- O. Manufacturer Certificates: Submit written statements on manufacturer's letterhead certifying that manufacturer complies with requirements in the Contract Documents. Include evidence of manufacturing experience where required.
- P. Product Certificates: Submit written statements on manufacturer's letterhead certifying that product complies with requirements in the Contract Documents.
- Q. Material Certificates: Submit written statements on manufacturer's letterhead certifying that material complies with requirements in the Contract Documents.
- R. Material Test Reports: Submit reports written by a qualified testing agency, on testing agency's standard form, indicating and interpreting test results of material for compliance with requirements in the Contract Documents.

- S. Product Test Reports: Submit written reports indicating that current product produced by manufacturer complies with requirements in the Contract Documents. Base reports on evaluation of tests performed by manufacturer and witnessed by a qualified testing agency, or on comprehensive tests performed by a qualified testing agency.
- T. Research Reports: Submit written evidence, from a model code organization acceptable to authorities having jurisdiction, that product complies with building code in effect for Project. Include the following information:
 - 1. Name of evaluation organization.
 - 2. Date of evaluation.
 - 3. Time period when report is in effect.
 - 4. Product and manufacturers' names.
 - 5. Description of product.
 - 6. Test procedures and results.
 - 7. Limitations of use.
- U. Preconstruction Test Reports: Submit reports written by a qualified testing agency, on testing agency's standard form, indicating and interpreting results of tests performed before installation of product, for compliance with performance requirements in the Contract Documents.
- V. Compatibility Test Reports: Submit reports written by a qualified testing agency, on testing agency's standard form, indicating and interpreting results of compatibility tests performed before installation of product. Include written recommendations for primers and substrate preparation needed for adhesion.
- W. Field Test Reports: Submit written reports indicating and interpreting results of field tests performed either during installation of product or after product is installed in its final location, for compliance with requirements in the Contract Documents.
- X. Design Data: Prepare and submit written and graphic information, including, but not limited to, performance and design criteria, list of applicable codes and regulations, and calculations. Include list of assumptions and other performance and design criteria and a summary of loads. Include load diagrams if applicable. Provide name and version of software, if any, used for calculations. Include page numbers.

2.2 DELEGATED-DESIGN SERVICES

- A. Performance and Design Criteria: Where professional design services or certifications by a design professional are specifically required of Contractor by the Contract Documents, provide products and systems complying with specific performance and design criteria indicated.
 - 1. If criteria indicated are not sufficient to perform services or certification required, submit a written request for additional information to Architect.

PART 3 - EXECUTION

3.1 CONTRACTOR'S REVIEW

- A. Action and Informational Submittals: Review each submittal and check for coordination with other Work of the Contract and for compliance with the Contract Documents. Note corrections and field dimensions. Mark with approval stamp before submitting to Architect.
- B. Project Closeout and Maintenance Material Submittals: See requirements in Division 01 Section "Closeout Procedures."
- C. Approval Stamp: Stamp each submittal with a uniform, approval stamp. Include Project name and location, submittal number, Specification Section title and number, name of reviewer, date of Contractor's approval, and statement certifying that submittal has been reviewed, checked, and approved for compliance with the Contract Documents.

3.2 ARCHITECT'S ACTION

- A. Action Submittals: Architect will review each submittal, make marks to indicate corrections or revisions required, and return it. Architect will stamp each submittal with an action stamp and will mark stamp appropriately to indicate action.
- B. Informational Submittals: Architect will review each submittal and will not return it, or will return it if it does not comply with requirements. Architect will forward each submittal to appropriate party.
- C. Partial submittals prepared for a portion of the Work will be reviewed when use of partial submittals has received prior approval from Architect.
- D. Incomplete submittals are unacceptable, will be considered nonresponsive, and will be returned for resubmittal without review.
- E. Submittals not required by the Contract Documents may be returned by the Architect without action.

END OF SECTION 013300

SECTION 014000 - QUALITY REQUIREMENTS

PART 1 - GENERAL

1.1 RELATED DOCUMENTS

- A. Drawings and general provisions of the Contract, including General and Supplementary Conditions and other Division 01 Specification Sections, apply to this Section.

1.2 SUMMARY

- A. Section includes administrative and procedural requirements for quality assurance and quality control.
- B. Testing and inspecting services are required to verify compliance with requirements specified or indicated. These services do not relieve Contractor of responsibility for compliance with the Contract Document requirements.
 - 1. Specific quality-control requirements for individual construction activities are specified in the Sections that specify those activities. Requirements in those Sections may also cover production of standard products.
 - 2. Specified tests, inspections, and related actions do not limit Contractor's quality-control procedures that facilitate compliance with the Contract Document requirements.
 - 3. Requirements for Contractor to provide quality-control services required by Architect, Owner, or authorities having jurisdiction are not limited by provisions of this Section.

1.3 DEFINITIONS

- A. Quality-Assurance Services: Activities, actions, and procedures performed before and during execution of the Work to guard against defects and deficiencies and ensure that proposed construction complies with requirements.
- B. Quality-Control Services: Tests, inspections, procedures, and related actions during and after execution of the Work to evaluate that completed construction complies with requirements. Services do not include contract enforcement activities performed by Architect.
- C. Mockups: Full-size, physical example assemblies to illustrate finishes and materials. Mockups are used to verify selections made under Sample submittals, to demonstrate aesthetic effects and, where indicated, qualities of materials and execution, and to review construction, coordination, testing, or operation; they are not Samples. Mockups establish the standard by which the Work will be judged.

- D. Preconstruction Testing: Tests and inspections performed specifically for Project before products and materials are incorporated into the Work, to verify performance or compliance with specified criteria.
- E. Product Testing: Tests and inspections that are performed by an NRTL, an NVLAP, or a testing agency qualified to conduct product testing and acceptable to authorities having jurisdiction, to establish product performance and compliance with specified requirements.
- F. Source Quality-Control Testing: Tests and inspections that are performed at the source, e.g., plant, mill, factory, or shop.
- G. Field Quality-Control Testing: Tests and inspections that are performed on-site for installation of the Work and for completed Work.
- H. Testing Agency: An entity engaged to perform specific tests, inspections, or both. Testing laboratory shall mean the same as testing agency.
- I. Installer/Applicator/Erector: Contractor or another entity engaged by Contractor as an employee, Subcontractor, or Sub-subcontractor, to perform a particular construction operation, including installation, erection, application, and similar operations.
 - 1. Use of trade-specific terminology in referring to a trade or entity does not require that certain construction activities be performed by accredited or unionized individuals, or that requirements specified apply exclusively to specific trade(s).
- J. Experienced: When used with an entity or individual, "experienced" means having successfully completed a minimum of five previous projects similar in nature, size, and extent to this Project; being familiar with special requirements indicated; and having complied with requirements of authorities having jurisdiction.

1.4 CONFLICTING REQUIREMENTS

- A. Referenced Standards: If compliance with two or more standards is specified and the standards establish different or conflicting requirements for minimum quantities or quality levels, comply with the most stringent requirement. Refer conflicting requirements that are different, but apparently equal, to Architect for a decision before proceeding.
- B. Minimum Quantity or Quality Levels: The quantity or quality level shown or specified shall be the minimum provided or performed. The actual installation may comply exactly with the minimum quantity or quality specified, or it may exceed the minimum within reasonable limits. To comply with these requirements, indicated numeric values are minimum or maximum, as appropriate, for the context of requirements. Refer uncertainties to Architect for a decision before proceeding.

1.5 INFORMATIONAL SUBMITTALS

- A. Testing Agency Qualifications: For testing agencies specified in "Quality Assurance" Article to demonstrate their capabilities and experience. Include proof of qualifications in the form of a recent report on the inspection of the testing agency by a recognized authority.
- B. Schedule of Tests and Inspections: Prepare in tabular form and include the following:
 - 1. Specification Section number and title.
 - 2. Description of test and inspection.
 - 3. Identification of applicable standards.
 - 4. Identification of test and inspection methods.
 - 5. Number of tests and inspections required.
 - 6. Time schedule or time span for tests and inspections.
 - 7. Entity responsible for performing tests and inspections.
 - 8. Requirements for obtaining samples.
 - 9. Unique characteristics of each quality-control service.

1.6 REPORTS AND DOCUMENTS

- A. Test and Inspection Reports: Prepare and submit certified written reports specified in other Sections. Include the following:
 - 1. Date of issue.
 - 2. Project title and number.
 - 3. Name, address, and telephone number of testing agency.
 - 4. Dates and locations of samples and tests or inspections.
 - 5. Names of individuals making tests and inspections.
 - 6. Description of the Work and test and inspection method.
 - 7. Identification of product and Specification Section.
 - 8. Complete test or inspection data.
 - 9. Test and inspection results and an interpretation of test results.
 - 10. Ambient conditions at time of sample taking and testing and inspecting.
 - 11. Comments or professional opinion on whether tested or inspected Work complies with the Contract Document requirements.
 - 12. Name and signature of laboratory inspector.
 - 13. Recommendations on retesting and reinspecting.
- B. Manufacturer's Technical Representative's Field Reports: Prepare written information documenting manufacturer's technical representative's tests and inspections specified in other Sections. Include the following:
 - 1. Name, address, and telephone number of technical representative making report.
 - 2. Statement on condition of substrates and their acceptability for installation of product.
 - 3. Statement that products at Project site comply with requirements.
 - 4. Summary of installation procedures being followed, whether they comply with requirements and, if not, what corrective action was taken.

5. Results of operational and other tests and a statement of whether observed performance complies with requirements.
 6. Statement whether conditions, products, and installation will affect warranty.
 7. Other required items indicated in individual Specification Sections.
- C. Factory-Authorized Service Representative's Reports: Prepare written information documenting manufacturer's factory-authorized service representative's tests and inspections specified in other Sections. Include the following:
1. Name, address, and telephone number of factory-authorized service representative making report.
 2. Statement that equipment complies with requirements.
 3. Results of operational and other tests and a statement of whether observed performance complies with requirements.
 4. Statement whether conditions, products, and installation will affect warranty.
 5. Other required items indicated in individual Specification Sections.
- D. Permits, Licenses, and Certificates: For Owner's records, submit copies of permits, licenses, certifications, inspection reports, releases, jurisdictional settlements, notices, receipts for fee payments, judgments, correspondence, records, and similar documents, established for compliance with standards and regulations bearing on performance of the Work.

1.7 QUALITY ASSURANCE

- A. General: Qualifications paragraphs in this article establish the minimum qualification levels required; individual Specification Sections specify additional requirements.
- B. Manufacturer Qualifications: A firm experienced in manufacturing products or systems similar to those indicated for this Project and with a record of successful in-service performance, as well as sufficient production capacity to produce required units.
- C. Fabricator Qualifications: A firm experienced in producing products similar to those indicated for this Project and with a record of successful in-service performance, as well as sufficient production capacity to produce required units.
- D. Installer Qualifications: A firm or individual experienced in installing, erecting, or assembling work similar in material, design, and extent to that indicated for this Project, whose work has resulted in construction with a record of successful in-service performance.
- E. Professional Engineer Qualifications: A professional engineer who is legally qualified to practice in jurisdiction where Project is located and who is experienced in providing engineering services of the kind indicated. Engineering services are defined as those performed for installations of the system, assembly, or product that are similar in material, design, and extent to those indicated for this Project.
- F. Specialists: Certain Specification Sections require that specific construction activities shall be performed by entities who are recognized experts in those operations.

Specialists shall satisfy qualification requirements indicated and shall be engaged for the activities indicated.

1. Requirements of authorities having jurisdiction shall supersede requirements for specialists.
- G. Testing Agency Qualifications: An NRTL, an NVLAP, or an independent agency with the experience and capability to conduct testing and inspecting indicated, as documented according to ASTM E 329; and with additional qualifications specified in individual Sections; and, where required by authorities having jurisdiction, that is acceptable to authorities.
1. NRTL: A nationally recognized testing laboratory according to 29 CFR 1910.7.
 2. NVLAP: A testing agency accredited according to NIST's National Voluntary Laboratory Accreditation Program.
- H. Manufacturer's Technical Representative Qualifications: An authorized representative of manufacturer who is trained and approved by manufacturer to observe and inspect installation of manufacturer's products that are similar in material, design, and extent to those indicated for this Project.
- I. Factory-Authorized Service Representative Qualifications: An authorized representative of manufacturer who is trained and approved by manufacturer to inspect installation of manufacturer's products that are similar in material, design, and extent to those indicated for this Project.
- J. Preconstruction Testing: Where testing agency is indicated to perform preconstruction testing for compliance with specified requirements for performance and test methods, comply with the following:
1. Contractor responsibilities include the following:
 - a. Provide test specimens representative of proposed products and construction.
 - b. Submit specimens in a timely manner with sufficient time for testing and analyzing results to prevent delaying the Work.
 - c. Provide sizes and configurations of test assemblies, mockups, and laboratory mockups to adequately demonstrate capability of products to comply with performance requirements.
 - d. Build laboratory mockups at testing facility using personnel, products, and methods of construction indicated for the completed Work.
 - e. When testing is complete, remove test specimens, assemblies, and mockups, and laboratory mockups; do not reuse products on Project.
 2. Testing Agency Responsibilities: Submit a certified written report of each test, inspection, and similar quality-assurance service to Architect, with copy to Contractor. Interpret tests and inspections and state in each report whether tested and inspected work complies with or deviates from the Contract Documents.

- K. Mockups: Before installing portions of the Work requiring mockups, build mockups for each form of construction and finish required to comply with the following requirements, using materials indicated for the completed Work:
1. Build mockups in location and of size indicated or, if not indicated, as directed by Architect.
 2. Notify Architect seven days in advance of dates and times when mockups will be constructed.
 3. Employ supervisory personnel who will oversee mockup construction. Employ workers that will be employed during the construction at Project.
 4. Demonstrate the proposed range of aesthetic effects and workmanship.
 5. Obtain Architect's approval of mockups before starting work, fabrication, or construction.
 - a. Allow seven days for initial review and each re-review of each mockup.
 6. Maintain mockups during construction in an undisturbed condition as a standard for judging the completed Work.
 7. Demolish and remove mockups when directed, unless otherwise indicated.

1.8 QUALITY CONTROL

- A. Owner Responsibilities: Where quality-control services are indicated as Owner's responsibility, Owner will engage a qualified testing agency to perform these services.
1. Owner will furnish Contractor with names, addresses, and telephone numbers of testing agencies engaged and a description of the types of testing and inspecting they are engaged to perform.
 2. Costs for retesting and reinspecting construction that replaces or is necessitated by work that failed to comply with the Contract Documents will be charged to Contractor, and the Contract Sum will be adjusted by Change Order.
- B. Contractor Responsibilities: Tests and inspections not explicitly assigned to Owner are Contractor's responsibility. Perform additional quality-control activities required to verify that the Work complies with requirements, whether specified or not.
1. Unless otherwise indicated, provide quality-control services specified and those required by authorities having jurisdiction. Perform quality-control services required of Contractor by authorities having jurisdiction, whether specified or not.
 2. Where services are indicated as Contractor's responsibility, engage a qualified testing agency to perform these quality-control services.
 - a. Contractor shall not employ the same entity engaged by Owner, unless agreed to in writing by Owner.
 3. Notify testing agencies at least 24 hours in advance of time when Work that requires testing or inspecting will be performed.
 4. Where quality-control services are indicated as Contractor's responsibility, submit a certified written report, in duplicate, of each quality-control service.

5. Testing and inspecting requested by Contractor and not required by the Contract Documents are Contractor's responsibility.
 6. Submit additional copies of each written report directly to authorities having jurisdiction, when they so direct.
- C. **Manufacturer's Field Services:** Where indicated, engage a factory-authorized service representative to inspect field-assembled components and equipment installation, including service connections. Report results in writing as specified in Section 013300 "Submittal Procedures."
- D. **Manufacturer's Technical Services:** Where indicated, engage a manufacturer's technical representative to observe and inspect the Work. Manufacturer's technical representative's services include participation in preinstallation conferences, examination of substrates and conditions, verification of materials, observation of Installer activities, inspection of completed portions of the Work, and submittal of written reports.
- E. **Retesting/Reinspecting:** Regardless of whether original tests or inspections were Contractor's responsibility, provide quality-control services, including retesting and reinspecting, for construction that replaced Work that failed to comply with the Contract Documents.
- F. **Testing Agency Responsibilities:** Cooperate with Architect and Contractor in performance of duties. Provide qualified personnel to perform required tests and inspections.
1. Notify Architect and Contractor promptly of irregularities or deficiencies observed in the Work during performance of its services.
 2. Determine the location from which test samples will be taken and in which in-situ tests are conducted.
 3. Conduct and interpret tests and inspections and state in each report whether tested and inspected work complies with or deviates from requirements.
 4. Submit a certified written report, in duplicate, of each test, inspection, and similar quality-control service through Contractor.
 5. Do not release, revoke, alter, or increase the Contract Document requirements or approve or accept any portion of the Work.
 6. Do not perform any duties of Contractor.
- G. **Associated Services:** Cooperate with agencies performing required tests, inspections, and similar quality-control services, and provide reasonable auxiliary services as requested. Notify agency sufficiently in advance of operations to permit assignment of personnel. Provide the following:
1. Access to the Work.
 2. Incidental labor and facilities necessary to facilitate tests and inspections.
 3. Adequate quantities of representative samples of materials that require testing and inspecting. Assist agency in obtaining samples.
 4. Facilities for storage and field-curing of test samples.
 5. Delivery of samples to testing agencies.

6. Preliminary design mix proposed for use for material mixes that require control by testing agency.
 7. Security and protection for samples and for testing and inspecting equipment at Project site.
- H. Coordination: Coordinate sequence of activities to accommodate required quality-assurance and quality-control services with a minimum of delay and to avoid necessity of removing and replacing construction to accommodate testing and inspecting.
1. Schedule times for tests, inspections, obtaining samples, and similar activities.
- I. Schedule of Tests and Inspections: Prepare a schedule of tests, inspections, and similar quality-control services required by the Contract Documents. Submit schedule within 20 days of date established for the Notice to Proceed.
1. Distribution: Distribute schedule to Owner, Architect, Construction Manager, testing agencies, and each party involved in performance of portions of the Work where tests and inspections are required.

1.9 SPECIAL TESTS AND INSPECTIONS

- A. Special Tests and Inspections: Owner will engage a qualified testing agency to conduct special tests and inspections required by authorities having jurisdiction as the responsibility of Owner.
1. Verifying that manufacturer maintains detailed fabrication and quality-control procedures and reviews the completeness and adequacy of those procedures to perform the Work.
 2. Notifying Architect and Contractor promptly of irregularities and deficiencies observed in the Work during performance of its services.
 3. Submitting a certified written report of each test, inspection, and similar quality-control service to Architect with copy to Contractor and to authorities having jurisdiction.
 4. Submitting a final report of special tests and inspections at Substantial Completion, which includes a list of unresolved deficiencies.
 5. Interpreting tests and inspections and stating in each report whether tested and inspected work complies with or deviates from the Contract Documents.
 6. Retesting and reinspecting corrected work.

PART 2 - PRODUCTS (Not Used)

PART 3 - EXECUTION

3.1 TEST AND INSPECTION LOG

- A. Test and Inspection Log: Prepare a record of tests and inspections. Include the following:
 - 1. Date test or inspection was conducted.
 - 2. Description of the Work tested or inspected.
 - 3. Date test or inspection results were transmitted to Architect.
 - 4. Identification of testing agency or special inspector conducting test or inspection.
- B. Maintain log at Project site. Post changes and revisions as they occur. Provide access to test and inspection log for Architect's reference during normal working hours.

3.2 REPAIR AND PROTECTION

- A. General: On completion of testing, inspecting, sample taking, and similar services, repair damaged construction and restore substrates and finishes.
 - 1. Provide materials and comply with installation requirements specified in other Specification Sections or matching existing substrates and finishes. Restore patched areas and extend restoration into adjoining areas with durable seams that are as invisible as possible. Comply with the Contract Document requirements for cutting and patching in Section 017300 "Execution."
- B. Protect construction exposed by or for quality-control service activities.
- C. Repair and protection are Contractor's responsibility, regardless of the assignment of responsibility for quality-control services.

END OF SECTION 014000

SECTION 014200 - REFERENCES

PART 1 - GENERAL

1.1 RELATED DOCUMENTS

- A. Drawings and general provisions of the Contract, including General and Supplementary Conditions and other Division 01 Specification Sections, apply to this Section.

1.2 DEFINITIONS

- A. General: Basic Contract definitions are included in the Conditions of the Contract.
- B. "Approved:" When used to convey Architect's action on Contractor's submittals, applications, and requests, "approved" is limited to Architect's duties and responsibilities as stated in the Conditions of the Contract.
- C. "Directed:" A command or instruction by Architect. Other terms including "requested," "authorized," "selected," "approved," "required," and "permitted" have the same meaning as "directed."
- D. "Indicated:" Requirements expressed by graphic representations or in written form on Drawings, in Specifications, and in other Contract Documents. Other terms including "shown," "noted," "scheduled," and "specified" have the same meaning as "indicated."
- E. "Regulations:" Laws, ordinances, statutes, and lawful orders issued by authorities having jurisdiction, and rules, conventions, and agreements within the construction industry that control performance of the Work.
- F. "Furnish:" Supply and deliver to Project site, ready for unloading, unpacking, assembly, installation, and similar operations.
- G. "Install:" Operations at Project site including unloading, temporarily storing, unpacking, assembling, erecting, placing, anchoring, applying, working to dimension, finishing, curing, protecting, cleaning, and similar operations.
- H. "Provide:" Furnish and install, complete and ready for the intended use.
- I. "Project Site:" Space available for performing construction activities. The extent of Project site is shown on Drawings and may or may not be identical with the description of the land on which Project is to be built.

1.3 INDUSTRY STANDARDS

- A. Applicability of Standards: Unless the Contract Documents include more stringent requirements, applicable construction industry standards have the same force and

effect as if bound or copied directly into the Contract Documents to the extent referenced. Such standards are made a part of the Contract Documents by reference.

- B. Publication Dates: Comply with standards in effect as of date of the Contract Documents, unless otherwise indicated.
- C. Copies of Standards: Each entity engaged in construction on Project must be familiar with industry standards applicable to its construction activity. Copies of applicable standards are not bound with the Contract Documents.
 - 1. Where copies of standards are needed to perform a required construction activity, obtain copies directly from publication source and make them available on request.

1.4 ABBREVIATIONS AND ACRONYMS

- A. Abbreviations and Acronyms: Where abbreviations and acronyms are used in Specifications or other Contract Documents, they shall mean the recognized name of the entity indicated in Gale Research's "Encyclopedia of Associations" or in Columbia Books' "National Trade & Professional Associations of the U.S."

PART 2 - PRODUCTS (Not Used)

PART 3 - EXECUTION (Not Used)

END OF SECTION 014200

SECTION 016000 - PRODUCT REQUIREMENTS

PART 1 - GENERAL

1.1 RELATED DOCUMENTS

- A. Drawings and general provisions of the Contract, including General and Supplementary Conditions and other Division 01 Specification Sections, apply to this Section.

1.2 SUMMARY

- A. Section includes administrative and procedural requirements for selection of products for use in Project; product delivery, storage, and handling; manufacturers' standard warranties on products; special warranties; and comparable products.
- B. Related Requirements:
 - 1. Division 01 Section "Alternates" for products selected under an alternate.
 - 2. Division 01 Section "Substitution Procedures" for requests for substitutions.
 - 3. Division 01 Section "References" for applicable industry standards for products specified.

1.3 DEFINITIONS

- A. Products: Items obtained for incorporating into the Work, whether purchased for Project or taken from previously purchased stock. The term "product" includes the terms "material," "equipment," "system," and terms of similar intent.
 - 1. Named Products: Items identified by manufacturer's product name, including make or model number or other designation shown or listed in manufacturer's published product literature, that is current as of date of the Contract Documents.
 - 2. New Products: Items that have not previously been incorporated into another project or facility. Products salvaged or recycled from other projects are not considered new products.
 - 3. Comparable Product: Product that is demonstrated and approved through submittal process to have the indicated qualities related to type, function, dimension, in-service performance, physical properties, appearance, and other characteristics that equal or exceed those of specified product.
- B. Basis-of-Design Product Specification: A specification in which a specific manufacturer's product is named and accompanied by the words "basis-of-design product," including make or model number or other designation, to establish the significant qualities related to type, function, dimension, in-service performance, physical properties, appearance, and other characteristics for purposes of evaluating comparable products of additional manufacturers named in the specification.

1.4 ACTION SUBMITTALS

- A. Comparable Product Requests: Submit request for consideration of each comparable product. Identify product or fabrication or installation method to be replaced. Include Specification Section number and title and Drawing numbers and titles.
 - 1. Include data to indicate compliance with the requirements specified in "Comparable Products" Article.
 - 2. Architect's Action: If necessary, Architect will request additional information or documentation for evaluation within one week of receipt of a comparable product request. Architect will notify Contractor of approval or rejection of proposed comparable product request within 15 days of receipt of request, or seven days of receipt of additional information or documentation, whichever is later.
 - a. Form of Approval: As specified in Division 01 Section "Submittal Procedures."
 - b. Use product specified if Architect does not issue a decision on use of a comparable product request within time allocated.
- B. Basis-of-Design Product Specification Submittal: Comply with requirements in Division 01 Section "Submittal Procedures." Show compliance with requirements.

1.5 QUALITY ASSURANCE

- A. Compatibility of Options: If Contractor is given option of selecting between two or more products for use on Project, select product compatible with products previously selected, even if previously selected products were also options.

1.6 PRODUCT DELIVERY, STORAGE, AND HANDLING

- A. Deliver, store, and handle products using means and methods that will prevent damage, deterioration, and loss, including theft and vandalism. Comply with manufacturer's written instructions.
- B. Delivery and Handling:
 - 1. Schedule delivery to minimize long-term storage at Project site and to prevent overcrowding of construction spaces.
 - 2. Coordinate delivery with installation time to ensure minimum holding time for items that are flammable, hazardous, easily damaged, or sensitive to deterioration, theft, and other losses.
 - 3. Deliver products to Project site in an undamaged condition in manufacturer's original sealed container or other packaging system, complete with labels and instructions for handling, storing, unpacking, protecting, and installing.
 - 4. Inspect products on delivery to determine compliance with the Contract Documents and to determine that products are undamaged and properly protected.

C. Storage:

1. Store products to allow for inspection and measurement of quantity or counting of units.
2. Store materials in a manner that will not endanger Project structure.
3. Store products that are subject to damage by the elements, under cover in a weathertight enclosure above ground, with ventilation adequate to prevent condensation.
4. Protect foam plastic from exposure to sunlight, except to extent necessary for period of installation and concealment.
5. Comply with product manufacturer's written instructions for temperature, humidity, ventilation, and weather-protection requirements for storage.
6. Protect stored products from damage and liquids from freezing.
7. Provide a secure location and enclosure at Project site for storage of materials and equipment by Owner's construction forces. Coordinate location with Owner.

1.7 PRODUCT WARRANTIES

- A. Warranties specified in other Sections shall be in addition to, and run concurrent with, other warranties required by the Contract Documents. Manufacturer's disclaimers and limitations on product warranties do not relieve Contractor of obligations under requirements of the Contract Documents.
1. **Manufacturer's Warranty:** Written warranty furnished by individual manufacturer for a particular product and specifically endorsed by manufacturer to Owner.
 2. **Special Warranty:** Written warranty required by the Contract Documents to provide specific rights for Owner.
- B. **Special Warranties:** Prepare a written document that contains appropriate terms and identification, ready for execution.
1. **Manufacturer's Standard Form:** Modified to include Project-specific information and properly executed.
 2. **Specified Form:** When specified forms are included with the Specifications, prepare a written document using indicated form properly executed.
 3. See Divisions 02 through 33 Sections for specific content requirements and particular requirements for submitting special warranties.
- C. **Submittal Time:** Comply with requirements in Division 01 Section "Closeout Procedures."

PART 2 - PRODUCTS

2.1 PRODUCT SELECTION PROCEDURES

- A. General Product Requirements: Provide products that comply with the Contract Documents, are undamaged and, unless otherwise indicated, are new at time of installation.
1. Provide products complete with accessories, trim, finish, fasteners, and other items needed for a complete installation and indicated use and effect.
 2. Standard Products: If available, and unless custom products or nonstandard options are specified, provide standard products of types that have been produced and used successfully in similar situations on other projects.
 3. Owner reserves the right to limit selection to products with warranties not in conflict with requirements of the Contract Documents.
 4. Where products are accompanied by the term "as selected," Architect will make selection.
 5. Descriptive, performance, and reference standard requirements in the Specifications establish salient characteristics of products.
 6. Or Equal: For products specified by name and accompanied by the term "or equal," or "or approved equal," or "or approved," comply with requirements in "Comparable Products" Article to obtain approval for use of an unnamed product.
- B. Product Selection Procedures:
1. Product: Where Specifications name a single manufacturer and product, provide the named product that complies with requirements. Comparable products or substitutions for Contractor's convenience will not be considered.
 2. Manufacturer/Source: Where Specifications name a single manufacturer or source, provide a product by the named manufacturer or source that complies with requirements. Comparable products or substitutions for Contractor's convenience will not be considered.
 3. Products:
 - a. Restricted List: Where Specifications include a list of names of both manufacturers and products, provide one of the products listed that complies with requirements.
 - b. Nonrestricted List: Where Specifications include a list of names of both available manufacturers and products, provide one of the products listed, or an unnamed product, that complies with requirements. Comply with requirements in "Comparable Products" Article for consideration of an unnamed product.
 4. Manufacturers:
 - a. Restricted List: Where Specifications include a list of manufacturers' names, provide a product by one of the manufacturers listed that complies with requirements.
 - b. Nonrestricted List: Where Specifications include a list of available manufacturers, provide a product by one of the manufacturers listed, or a

product by an unnamed manufacturer, that complies with requirements. Comply with requirements in "Comparable Products" Article for consideration of an unnamed manufacturer's product.

5. Basis-of-Design Product: Where Specifications name a product, or refer to a product indicated on Drawings, and include a list of manufacturers, provide the specified or indicated product or a comparable product by one of the other named manufacturers. Drawings and Specifications indicate sizes, profiles, dimensions, and other characteristics that are based on the product named. Comply with requirements in "Comparable Products" Article for consideration of an unnamed product by one of the other named manufacturers.
- C. Visual Matching Specification: Where Specifications require "match Architect's sample", provide a product that complies with requirements and matches Architect's sample. Architect's decision will be final on whether a proposed product matches.
 1. If no product available within specified category matches and complies with other specified requirements, comply with requirements in Division 01 Section "Substitution Procedures" for proposal of product.
- D. Visual Selection Specification: Where Specifications include the phrase "as selected by Architect from manufacturer's full range" or similar phrase, select a product that complies with requirements. Architect will select color, gloss, pattern, density, or texture from manufacturer's product line that includes both standard and premium items.

2.2 COMPARABLE PRODUCTS

- A. Conditions for Consideration: Architect will consider Contractor's request for comparable product when the following conditions are satisfied. If the following conditions are not satisfied, Architect may return requests without action, except to record noncompliance with these requirements:
 1. Evidence that the proposed product does not require revisions to the Contract Documents, that it is consistent with the Contract Documents and will produce the indicated results, and that it is compatible with other portions of the Work.
 2. Detailed comparison of significant qualities of proposed product with those named in the Specifications. Significant qualities include attributes such as performance, weight, size, durability, visual effect, and specific features and requirements indicated.
 3. Evidence that proposed product provides specified warranty.
 4. List of similar installations for completed projects with project names and addresses and names and addresses of architects and owners, if requested.
 5. Samples, if requested.

PART 3 - EXECUTION (Not Used)

END OF SECTION 016000

SECTION 017300 - EXECUTION REQUIREMENTS

PART 1 - GENERAL

1.1 RELATED DOCUMENTS

- A. Drawings and general provisions of the Contract, including General and Supplementary Conditions and other Division 01 Specification Sections, apply to this Section.

1.2 SUMMARY

- A. Section includes general procedural requirements governing execution of the Work including, but not limited to, the following:
 - 1. Cutting and patching.
 - 2. Progress cleaning.
 - 3. Protection of installed construction.
- B. Related Requirements:
 - 1. Division 01 Section "Summary" for limits on use of Project site.
 - 2. Division 02 Section "Selective Demolition" for demolition and removal of selected portions of the building.

1.3 DEFINITIONS

- A. Cutting: Removal of in-place construction necessary to permit installation or performance of other work.
- B. Patching: Fitting and repair work required to restore construction to original conditions after installation of other work.

1.4 QUALITY ASSURANCE

- A. Cutting and Patching: Comply with requirements for and limitations on cutting and patching of construction elements.
 - 1. Construction Elements: Do not cut and patch other construction elements or components in a manner that could change their load-carrying capacity, that results in reducing their capacity to perform as intended, or that results in increased maintenance or decreased operational life or safety.
 - 2. Visual Elements: Do not cut and patch construction in a manner that results in visual evidence of cutting and patching. Do not cut and patch exposed construction in a manner that would, in Architect's opinion, reduce the building's

aesthetic qualities. Remove and replace construction that has been cut and patched in a visually unsatisfactory manner.

- B. Manufacturer's Installation Instructions: Obtain and maintain on-site manufacturer's written recommendations and instructions for installation of products and equipment.

PART 2 - PRODUCTS

2.1 MATERIALS

- A. General: Comply with requirements specified in other Sections.
 - 1. For projects requiring compliance with sustainable design and construction practices and procedures, use products for patching that comply with sustainability requirements indicated.
- B. In-Place Materials: Use materials for patching identical to in-place materials. For exposed surfaces, use materials that visually match in-place adjacent surfaces to the fullest extent possible.
 - 1. If identical materials are unavailable or cannot be used, use materials that, when installed, will provide a match acceptable to Architect for the visual and functional performance of in-place materials.

PART 3 - EXECUTION

3.1 EXAMINATION

- A. Existing Conditions: The existence and location of site improvements, utilities, and other construction indicated as existing are not guaranteed. Before beginning work, investigate and verify the existence and location of mechanical and electrical systems and other construction affecting the Work.
 - 1. Before construction, verify the location and invert elevation at points of connection of sanitary sewer, storm sewer, and water-service piping; underground electrical services, and other utilities.
 - 2. Furnish location data for work related to Project that must be performed by public utilities serving Project site.
- B. Examination and Acceptance of Conditions: Before proceeding with each component of the Work, examine substrates, areas, and conditions, with Installer or Applicator present where indicated, for compliance with requirements for installation tolerances and other conditions affecting performance. Record observations.
 - 1. Examine roughing-in for mechanical and electrical systems to verify actual locations of connections before equipment and fixture installation.
 - 2. Examine walls, floors, and roofs for suitable conditions where products and systems are to be installed.

3. Verify compatibility with and suitability of substrates, including compatibility with existing finishes or primers.
- C. Written Report: Where a written report listing conditions detrimental to performance of the Work is required by other Sections, include the following:
1. Description of the Work.
 2. List of detrimental conditions, including substrates.
 3. List of unacceptable installation tolerances.
 4. Recommended corrections.
- D. Proceed with installation only after unsatisfactory conditions have been corrected. Proceeding with the Work indicates acceptance of surfaces and conditions.

3.2 PREPARATION

- A. Existing Utility Information: Furnish information to local utility that is necessary to adjust, move, or relocate existing utility structures, utility poles, lines, services, or other utility appurtenances located in or affected by construction. Coordinate with authorities having jurisdiction.
- B. Field Measurements: Take field measurements as required to fit the Work properly. Recheck measurements before installing each product. Where portions of the Work are indicated to fit to other construction, verify dimensions of other construction by field measurements before fabrication. Coordinate fabrication schedule with construction progress to avoid delaying the Work.
- C. Space Requirements: Verify space requirements and dimensions of items shown diagrammatically on Drawings.
- D. Review of Contract Documents and Field Conditions: Immediately on discovery of the need for clarification of the Contract Documents, submit a request for information to Architect. Include a detailed description of problem encountered, together with recommendations for changing the Contract Documents.

3.3 CONSTRUCTION LAYOUT

- A. Verification: Before proceeding to lay out the Work, verify layout information shown on Drawings, in relation to the property survey and existing benchmarks. If discrepancies are discovered, notify Architect promptly.

3.4 INSTALLATION

- A. General: Locate the Work and components of the Work accurately, in correct alignment and elevation, as indicated.
1. Make vertical work plumb and make horizontal work level.
 2. Where space is limited, install components to maximize space available for maintenance and ease of removal for replacement.

3. Conceal pipes, ducts, and wiring in finished areas unless otherwise indicated.
 4. Maintain minimum headroom clearance of 96 inches in occupied spaces and 90 inches in unoccupied spaces.
- B. Comply with manufacturer's written instructions and recommendations for installing products in applications indicated.
 - C. Install products at the time and under conditions that will ensure the best possible results. Maintain conditions required for product performance until Substantial Completion.
 - D. Conduct construction operations so no part of the Work is subjected to damaging operations or loading in excess of that expected during normal conditions of occupancy.
 - E. Sequence the Work and allow adequate clearances to accommodate movement of construction items on site and placement in permanent locations.
 - F. Tools and Equipment: Do not use tools or equipment that produce harmful noise levels.
 - G. Templates: Obtain and distribute to the parties involved templates for work specified to be factory prepared and field installed. Check Shop Drawings of other work to confirm that adequate provisions are made for locating and installing products to comply with indicated requirements.
 - H. Attachment: Provide blocking and attachment plates and anchors and fasteners of adequate size and number to securely anchor each component in place, accurately located and aligned with other portions of the Work. Where size and type of attachments are not indicated, verify size and type required for load conditions.
 1. Mounting Heights: Where mounting heights are not indicated, mount components at heights directed by Architect.
 2. Allow for building movement, including thermal expansion and contraction.
 3. Coordinate installation of anchorages. Furnish setting drawings, templates, and directions for installing anchorages, including sleeves, concrete inserts, anchor bolts, and items with integral anchors, that are to be embedded in concrete or masonry. Deliver such items to Project site in time for installation.
 - I. Joints: Make joints of uniform width. Where joint locations in exposed work are not indicated, arrange joints for the best visual effect. Fit exposed connections together to form hairline joints.
 - J. Hazardous Materials: Use products, cleaners, and installation materials that are not considered hazardous.

3.5 CUTTING AND PATCHING

- A. Cutting and Patching, General: Employ skilled workers to perform cutting and patching. Proceed with cutting and patching at the earliest feasible time, and complete without delay.
 - 1. Cut in-place construction to provide for installation of other components or performance of other construction, and subsequently patch as required to restore surfaces to their original condition.
- B. Existing Warranties: Remove, replace, patch, and repair materials and surfaces cut or damaged during installation or cutting and patching operations, by methods and with materials so as not to void existing warranties.
- C. Temporary Support: Provide temporary support of work to be cut.
- D. Protection: Protect in-place construction during cutting and patching to prevent damage. Provide protection from adverse weather conditions for portions of Project that might be exposed during cutting and patching operations.
- E. Adjacent Occupied Areas: Where interference with use of adjoining areas or interruption of free passage to adjoining areas is unavoidable, coordinate cutting and patching according to requirements in Division 01 Section "Summary."
- F. Existing Utility Services and Mechanical/Electrical Systems: Where existing services/systems are required to be removed, relocated, or abandoned, bypass such services/systems before cutting to minimize interruption to occupied areas.
- G. Cutting: Cut in-place construction by sawing, drilling, breaking, chipping, grinding, and similar operations, including excavation, using methods least likely to damage elements retained or adjoining construction. If possible, review proposed procedures with original Installer; comply with original Installer's written recommendations.
 - 1. In general, use hand or small power tools designed for sawing and grinding, not hammering and chopping. Cut holes and slots neatly to minimum size required, and with minimum disturbance of adjacent surfaces. Temporarily cover openings when not in use.
 - 2. Finished Surfaces: Cut or drill from the exposed or finished side into concealed surfaces.
 - 3. Concrete and Masonry: Cut using a cutting machine, such as an abrasive saw or a diamond-core drill.
 - 4. Excavating and Backfilling: Comply with requirements in applicable Division 31 Sections where required by cutting and patching operations.
 - 5. Mechanical and Electrical Services: Cut off pipe or conduit in walls or partitions to be removed. Cap, valve, or plug and seal remaining portion of pipe or conduit to prevent entrance of moisture or other foreign matter after cutting.
 - 6. Proceed with patching after construction operations requiring cutting are complete.
- H. Patching: Patch construction by filling, repairing, refinishing, closing up, and similar operations following performance of other work. Patch with durable seams that are as

invisible as practicable. Provide materials and comply with installation requirements specified in other Sections, where applicable.

1. Inspection: Where feasible, test and inspect patched areas after completion to demonstrate physical integrity of installation.
2. Exposed Finishes: Restore exposed finishes of patched areas and extend finish restoration into retained adjoining construction in a manner that will minimize evidence of patching and refinishing.
 - a. Clean piping, conduit, and similar features before applying paint or other finishing materials.
 - b. Restore damaged pipe covering to its original condition.
3. Floors and Walls: Where walls or partitions that are removed extend one finished area into another, patch and repair floor and wall surfaces in the new space. Provide an even surface of uniform finish, color, texture, and appearance. Remove in-place floor and wall coverings and replace with new materials, if necessary, to achieve uniform color and appearance.
 - a. Where patching occurs in a painted surface, prepare substrate and apply primer and intermediate paint coats appropriate for substrate over the patch, and apply final paint coat over entire unbroken surface containing the patch. Provide additional coats until patch blends with adjacent surfaces.
4. Ceilings: Patch, repair, or rehang in-place ceilings as necessary to provide an even-plane surface of uniform appearance.
5. Exterior Building Enclosure: Patch components in a manner that restores enclosure to a weathertight condition and ensures thermal and moisture integrity of building enclosure.
 - I. Cleaning: Clean areas and spaces where cutting and patching are performed. Remove paint, mortar, oils, putty, and similar materials from adjacent finished surfaces.

3.6 PROGRESS CLEANING

- A. General: Clean Project site and work areas daily, including common areas. Coordinate progress cleaning for joint-use areas where other contracts worked. Enforce requirements strictly. Dispose of materials lawfully.
 1. Comply with requirements in NFPA 241 for removal of combustible waste materials and debris.
 2. Do not hold materials more than 7 days during normal weather or 3 days if the temperature is expected to rise above 80 deg F.
 3. Containerize hazardous and unsanitary waste materials separately from other waste. Mark containers appropriately and dispose of legally, according to regulations.
 - a. Use containers intended for holding waste materials of type to be stored.

- B. Site: Maintain Project site free of waste materials and debris.
- C. Work Areas: Clean areas where work is in progress to the level of cleanliness necessary for proper execution of the Work.
 - 1. Remove liquid spills promptly.
 - 2. Where dust would impair proper execution of the Work, broom-clean or vacuum the entire work area, as appropriate.
- D. Installed Work: Keep installed work clean. Clean installed surfaces according to written instructions of manufacturer or fabricator of product installed, using only cleaning materials specifically recommended. If specific cleaning materials are not recommended, use cleaning materials that are not hazardous to health or property and that will not damage exposed surfaces.
- E. Concealed Spaces: Remove debris from concealed spaces before enclosing the space.
- F. Exposed Surfaces in Finished Areas: Clean exposed surfaces and protect as necessary to ensure freedom from damage and deterioration at time of Substantial Completion.
- G. Waste Disposal: Do not bury or burn waste materials on-site. Do not wash waste materials down sewers or into waterways. Comply with waste disposal requirements in Division 01 Section "Construction Waste Management and Disposal."
- H. During handling and installation, clean and protect construction in progress and adjoining materials already in place. Apply protective covering where required to ensure protection from damage or deterioration at Substantial Completion.
- I. Clean and provide maintenance on completed construction as frequently as necessary through the remainder of the construction period. Adjust and lubricate operable components to ensure operability without damaging effects.
- J. Limiting Exposures: Supervise construction operations to assure that no part of the construction, completed or in progress, is subject to harmful, dangerous, damaging, or otherwise deleterious exposure during the construction period.

3.7 PROTECTION OF INSTALLED CONSTRUCTION

- A. Provide final protection and maintain conditions that ensure installed Work is without damage or deterioration at time of Substantial Completion.
- B. Comply with manufacturer's written instructions for temperature and relative humidity.

END OF SECTION 017300

SECTION 017700 - CLOSEOUT PROCEDURES

PART 1 - GENERAL

1.1 RELATED DOCUMENTS

- A. Drawings and general provisions of the Contract, including General and Supplementary Conditions and other Division 01 Specification Sections, apply to this Section.

1.2 SUMMARY

- A. Section includes administrative and procedural requirements for contract closeout, including, but not limited to, the following:
 - 1. Substantial Completion procedures.
 - 2. Final completion procedures.
 - 3. Warranties.
 - 4. Final cleaning.
 - 5. Repair of the Work.
- B. Related Requirements:
 - 1. Division 01 Section "Operation and Maintenance Data" for operation and maintenance manual requirements.
 - 2. Division 01 Section "Project Record Documents" for submitting record Drawings, record Specifications, and record Product Data.
 - 3. Division 01 Section "Demonstration and Training" for requirements for instructing Owner's personnel.

1.3 ACTION SUBMITTALS

- A. Product Data: For cleaning agents.
- B. Contractor's List of Incomplete Items: Initial submittal at Substantial Completion.
- C. Certified List of Incomplete Items: Final submittal at Final Completion.

1.4 CLOSEOUT SUBMITTALS

- A. Certificates of Release: From authorities having jurisdiction.
- B. Certificate of Insurance: For continuing coverage.
- C. Field Report: For pest control inspection.

1.5 MAINTENANCE MATERIAL SUBMITTALS

- A. Schedule of Maintenance Material Items: For maintenance material submittal items specified in other Sections.

1.6 SUBSTANTIAL COMPLETION PROCEDURES

- A. Contractor's List of Incomplete Items: Prepare and submit a list of items to be completed and corrected (Contractor's punch list), indicating the value of each item on the list and reasons why the Work is incomplete.
- B. Submittals Prior to Substantial Completion: Complete the following a minimum of 10 days prior to requesting inspection for determining date of Substantial Completion. List items below that are incomplete at time of request.
 - 1. Certificates of Release: Obtain and submit releases from authorities having jurisdiction permitting Owner unrestricted use of the Work and access to services and utilities. Include occupancy permits, operating certificates, and similar releases.
 - 2. Submit closeout submittals specified in other Division 01 Sections, including project record documents, operation and maintenance manuals, final completion construction photographic documentation, damage or settlement surveys, property surveys, and similar final record information.
 - 3. Submit closeout submittals specified in individual Divisions 02 through 33 Sections, including specific warranties, workmanship bonds, maintenance service agreements, final certifications, and similar documents.
 - 4. Submit maintenance material submittals specified in individual Divisions 02 through 33 Sections, including tools, spare parts, extra materials, and similar items, and deliver to location designated by Architect. Label with manufacturer's name and model number where applicable.
 - a. Schedule of Maintenance Material Items: Prepare and submit schedule of maintenance material submittal items, including name and quantity of each item and name and number of related Specification Section. Obtain Architect's signature for receipt of submittals.
 - 5. Submit test/adjust/balance records.
 - 6. Submit sustainable design submittals required in Division 01 sustainable design requirements Section and in individual Division 02 through 33 Sections.
 - 7. Submit changeover information related to Owner's occupancy, use, operation, and maintenance.
- C. Procedures Prior to Substantial Completion: Complete the following a minimum of 10 days prior to requesting inspection for determining date of Substantial Completion. List items below that are incomplete at time of request.
 - 1. Advise Owner of pending insurance changeover requirements.
 - 2. Make final changeover of permanent locks and deliver keys to Owner. Advise Owner's personnel of changeover in security provisions.
 - 3. Complete startup and testing of systems and equipment.

4. Perform preventive maintenance on equipment used prior to Substantial Completion.
 5. Instruct Owner's personnel in operation, adjustment, and maintenance of products, equipment, and systems. Submit demonstration and training video recordings specified in Division 01 Section "Demonstration and Training."
 6. Advise Owner of changeover in heat and other utilities.
 7. Participate with Owner in conducting inspection and walkthrough with local emergency responders.
 8. Terminate and remove temporary facilities from Project site, along with mockups, construction tools, and similar elements.
 9. Complete final cleaning requirements, including touchup painting.
 10. Touch up and otherwise repair and restore marred exposed finishes to eliminate visual defects.
- D. Inspection: Submit a written request for inspection to determine Substantial Completion a minimum of 10 days prior to date the work will be completed and ready for final inspection and tests. On receipt of request, Architect will either proceed with inspection or notify Contractor of unfulfilled requirements. Architect will prepare the Certificate of Substantial Completion after inspection or will notify Contractor of items, either on Contractor's list or additional items identified by Architect, that must be completed or corrected before certificate will be issued.
1. Reinspection: Request reinspection when the Work identified in previous inspections as incomplete is completed or corrected.
 2. Results of completed inspection will form the basis of requirements for final completion.

1.7 FINAL COMPLETION PROCEDURES

- A. Submittals Prior to Final Completion: Before requesting final inspection for determining final completion, complete the following:
1. Submit a final Application for Payment according to Division 01 Section "Payment Procedures."
 2. Certified List of Incomplete Items: Submit certified copy of Architect's Substantial Completion inspection list of items to be completed or corrected (punch list), endorsed and dated by Architect. Certified copy of the list shall state that each item has been completed or otherwise resolved for acceptance.
 3. Certificate of Insurance: Submit evidence of final, continuing insurance coverage complying with insurance requirements.
 4. Submit pest-control final inspection report.

- B. Inspection: Submit a written request for final inspection to determine acceptance a minimum of 10 days prior to date the work will be completed and ready for final inspection and tests. On receipt of request, Architect will either proceed with inspection or notify Contractor of unfulfilled requirements. Architect will prepare a final Certificate for Payment after inspection or will notify Contractor of construction that must be completed or corrected before certificate will be issued.
 - 1. Reinspection: Request reinspection when the Work identified in previous inspections as incomplete is completed or corrected.

1.8 LIST OF INCOMPLETE ITEMS (PUNCH LIST)

- A. Organization of List: Include name and identification of each space and area affected by construction operations for incomplete items and items needing correction including, if necessary, areas disturbed by Contractor that are outside the limits of construction. Use form acceptable to Architect.
 - 1. Organize list of spaces in sequential order.
 - 2. Organize items applying to each space by major element, including categories for ceiling, individual walls, floors, equipment, and building systems.
 - 3. Include the following information at the top of each page:
 - a. Project name.
 - b. Date.
 - c. Name of Architect.
 - d. Name of Contractor.
 - e. Page number.
 - 4. Submit list of incomplete items in one of the following format:
 - a. MS Excel electronic file. Architect will return annotated file.
 - b. PDF electronic file. Architect will return annotated file.

1.9 SUBMITTAL OF PROJECT WARRANTIES

- A. Time of Submittal: Submit written warranties on request of Architect for designated portions of the Work where commencement of warranties other than date of Substantial Completion is indicated, or when delay in submittal of warranties might limit Owner's rights under warranty.
- B. Partial Occupancy: Submit properly executed warranties within 15 days of completion of designated portions of the Work that are completed and occupied or used by Owner during construction period by separate agreement with Contractor.
- C. Organize warranty documents into an orderly sequence based on the table of contents of Project Manual.
 - 1. Warranty Electronic File: Scan warranties and assemble complete warranty submittal package into a single indexed electronic PDF file with links enabling

navigation to each item. Provide bookmarked table of contents at beginning of document.

- D. Provide additional copies of each warranty to include in operation and maintenance manuals.

1.10 ELECTRONIC CLOSEOUT DOCUMENTATION

- A. General: Provide a complete project closeout documentation package in electronic format. This package shall include:

1. Issued for Construction Plans, Specs
2. Project Record Documents.
3. **Approved** Submittals.
4. Operation and Maintenance Manuals.
5. Warranties.
6. Owner training Videos (.WMV or .MP4 Format)
7. Project Contact Directory.

- B. The Electronic Closeout Documentation shall be prepared by BHFx Imaging. **Contractors are responsible for all Closeout Fees.** Please contact Sarah Jacobs at 847-593-3161 x. 206 or sarah.jacobs@bhfx.net for Pricing and Closeout Organization Information

- C. In order to facilitate the Electronic Closeout Documentation process, comply with the following procedures:

1. Contact BHFx Imaging for a Project Order Form a minimum of three months prior to the date of Substantial Completion to schedule a pre-closeout meeting. Review the following:
 - a. Format of documents: PDF electronic format for all documents.
 - b. Folder structure for storage and transfer of files.
 - c. Schedule for collection and turn-over of closeout documentation.
 - d. Record Document format procedures: Provide clean and accurate paper copies of the marked-up Record Documents (Drawings and Specifications) for scanning.
 - e. Provide contact information for the individual responsible for the collection and transfer of the Electronic Closeout Documentation Package contents.
 - f. Review a complete listing of Electronic Closeout Documentation Package contents.
2. **Multi-Building Projects - Submittals must be sorted by building**
 - a. Each submittal must be assigned to a building
 - b. Submittals pertaining to multiple buildings must be labeled or tagged with all buildings associated with that particular file.
 - c. Building specific folders can be generated. Files pertaining to multiple buildings must be added to all appropriate folders

3. Provide all documentation to BHFX Imaging for processing no later than 30 days after the date of Substantial Completion.
4. Schedule a training conference with the Owner's Representative, Architect, Construction Manager and BHFX Imaging to present the completed Electronic Closeout Documentation Package.

PART 2 - PRODUCTS

2.1 MATERIALS

- A. Cleaning Agents: Use cleaning materials and agents recommended by manufacturer or fabricator of the surface to be cleaned. Do not use cleaning agents that are potentially hazardous to health or property or that might damage finished surfaces.
 1. Use cleaning products that comply with Green Seal's GS-37, or if GS-37 is not applicable, use products that comply with the California Code of Regulations maximum allowable VOC levels.

PART 3 - EXECUTION

3.1 FINAL CLEANING

- A. General: Perform final cleaning. Conduct cleaning and waste-removal operations to comply with local laws and ordinances and Federal and local environmental and antipollution regulations.
- B. Cleaning: Clean each surface or unit to condition expected in an average commercial building cleaning and maintenance program. Comply with manufacturer's written instructions.
 1. Complete the following cleaning operations before requesting inspection for certification of Substantial Completion for entire Project or for a designated portion of Project:
 - a. Clean Project site, yard, and grounds, in areas disturbed by construction activities, including landscape development areas, of rubbish, waste material, litter, and other foreign substances.
 - b. Sweep paved areas broom clean. Remove petrochemical spills, stains, and other foreign deposits.
 - c. Rake grounds that are neither planted nor paved to a smooth, even-textured surface.
 - d. Remove tools, construction equipment, machinery, and surplus material from Project site.
 - e. Remove snow and ice to provide safe access to building.
 - f. Clean exposed exterior and interior hard-surfaced finishes to a dirt-free condition, free of stains, films, and similar foreign substances. Avoid

disturbing natural weathering of exterior surfaces. Restore reflective surfaces to their original condition.

- g. Remove debris and surface dust from limited access spaces, including roofs, plenums, shafts, trenches, equipment vaults, manholes, attics, and similar spaces.
 - h. Sweep concrete floors broom clean in unoccupied spaces.
 - i. Vacuum carpet and similar soft surfaces, removing debris and excess nap; clean according to manufacturer's recommendations if visible soil or stains remain.
 - j. Clean transparent materials, including mirrors and glass in doors and windows. Remove glazing compounds and other noticeable, vision-obscuring materials. Polish mirrors and glass, taking care not to scratch surfaces.
 - k. Remove labels that are not permanent.
 - l. Wipe surfaces of mechanical and electrical equipment, and similar equipment. Remove excess lubrication, paint and mortar droppings, and other foreign substances.
 - m. Clean plumbing fixtures to a sanitary condition, free of stains, including stains resulting from water exposure.
 - n. Replace disposable air filters and clean permanent air filters. Clean exposed surfaces of diffusers, registers, and grills.
 - o. Clean ducts, blowers, and coils if units were operated without filters during construction or that display contamination with particulate matter on inspection.
 - p. Clean light fixtures, lamps, globes, and reflectors to function with full efficiency.
 - q. Leave Project clean and ready for occupancy.
- C. Construction Waste Disposal: Comply with waste disposal requirements in Division 01 Section "Construction Waste Management and Disposal."

3.2 REPAIR OF THE WORK

- A. Complete repair and restoration operations before requesting inspection for determination of Substantial Completion.
- B. Repair or remove and replace defective construction. Repairing includes replacing defective parts, refinishing damaged surfaces, touching up with matching materials, and properly adjusting operating equipment. Where damaged or worn items cannot be repaired or restored, provide replacements. Remove and replace operating components that cannot be repaired. Restore damaged construction and permanent facilities used during construction to specified condition.
 - 1. Remove and replace chipped, scratched, and broken glass, reflective surfaces, and other damaged transparent materials.

2. Touch up and otherwise repair and restore marred or exposed finishes and surfaces. Replace finishes and surfaces that that already show evidence of repair or restoration.
 - a. Do not paint over "UL" and other required labels and identification, including mechanical and electrical nameplates. Remove paint applied to required labels and identification.
3. Replace parts subject to operating conditions during construction that may impede operation or reduce longevity.
4. Replace burned-out bulbs, bulbs noticeably dimmed by hours of use, and defective and noisy starters in fluorescent and mercury vapor fixtures to comply with requirements for new fixtures.

END OF SECTION 017700

SECTION 017823 - OPERATION AND MAINTENANCE DATA

PART 1 - GENERAL

1.1 RELATED DOCUMENTS

- A. Drawings and general provisions of the Contract, including General and Supplementary Conditions and other Division 01 Specification Sections, apply to this Section.

1.2 SUMMARY

- A. Section includes administrative and procedural requirements for preparing operation and maintenance manuals, including the following:
 - 1. Operation and maintenance documentation directory.
 - 2. Emergency manuals.
 - 3. Operation manuals for systems, subsystems, and equipment.
 - 4. Maintenance manuals for the care and maintenance of products, materials, finishes, systems and equipment.
- B. Related Requirements:
 - 1. Division 01 Section "Submittal Procedures" for submitting copies of submittals for operation and maintenance manuals.
 - 2. Division 01 Section "Closeout Procedures" for submitting operation and maintenance manuals.
 - 3. Division 01 Section "Project Record Documents" for preparing Record Drawings for operation and maintenance manuals.
 - 4. Divisions 02 through 48 Sections for specific operation and maintenance manual requirements for products in those Sections.

1.3 DEFINITIONS

- A. System: An organized collection of parts, equipment, or subsystems united by regular interaction.
- B. Subsystem: A portion of a system with characteristics similar to a system.

1.4 COORDINATION

- A. Where operation and maintenance documentation includes information on installations by more than one factory-authorized service representative, assemble and coordinate information furnished by representatives and prepare manuals.

1.5 SUBMITTALS

- A. Operations and Maintenance Manuals Submittal: Submit 2 copies of each manual in final form at least 15 days before final inspection. Architect will return copy with comments within 15 days after final inspection.
 - 1. Correct or modify each manual to comply with Architect's comments. Submit 3 copies of each corrected manual within 15 days of receipt of Architect's comments.

PART 2 - PRODUCTS

2.1 OPERATION AND MAINTENANCE DOCUMENTATION DIRECTORY

- A. Organization: Include a section in the directory for each of the following:
 - 1. List of documents.
 - 2. List of systems.
 - 3. List of equipment.
 - 4. Table of contents.
- B. List of Systems and Subsystems: List systems alphabetically. Include references to operation and maintenance manuals that contain information about each system.
- C. List of Equipment: List equipment for each system, organized alphabetically by system. For pieces of equipment not part of system, list alphabetically in separate list.
- D. Tables of Contents: Include a table of contents for each emergency, operation, and maintenance manual.
- E. Identification: In the documentation directory and in each operation and maintenance manual, identify each system, subsystem, and piece of equipment with the same designation used in the Contract Documents. If no designation exists, assign a designation according to ASHRAE Guideline 4, "Preparation of Operating and Maintenance Documentation for Building Systems."

2.2 MANUALS, GENERAL

- A. Organization: Unless otherwise indicated, organize each manual into a separate section for each system and subsystem, and a separate section for each piece of equipment not part of a system. Each manual shall contain the following materials, in the order listed:
 - 1. Title page.
 - 2. Table of contents.
 - 3. Manual contents.

- B. Title Page: Enclose title page in transparent plastic sleeve. Include the following information:
1. Subject matter included in manual.
 2. Name and address of Project.
 3. Name and address of Owner.
 4. Date of submittal.
 5. Name, address, and telephone number of Contractor.
 6. Name and address of Architect.
 7. Name and address of Construction Manager.
 8. Cross-reference to related systems in other operation and maintenance manuals.
- C. Table of Contents: List each product included in manual, identified by product name, indexed to the content of the volume, and cross-referenced to Specification Section number in Project Manual.
1. If operation or maintenance documentation requires more than one volume to accommodate data, include comprehensive table of contents for all volumes in each volume of the set.
- D. Manual Contents: Organize into sets of manageable size. Arrange contents alphabetically by system, subsystem, and equipment. If possible, assemble instructions for subsystems, equipment, and components of one system into a single binder.
1. Binders: Heavy-duty, 3-ring, vinyl-covered, loose-leaf binders, in thickness necessary to accommodate contents, sized to hold 8-1/2-by-11-inch paper; with clear plastic sleeve on spine to hold label describing contents and with pockets inside covers to hold folded oversize sheets.
 - a. If two or more binders are necessary to accommodate data of a system, organize data in each binder into groupings by subsystem and related components. Cross-reference other binders if necessary to provide essential information for proper operation or maintenance of equipment or system.
 - b. Identify each binder on front and spine, with printed title "OPERATION AND MAINTENANCE MANUAL," Project title or name, and subject matter of contents. Indicate volume number for multiple-volume sets.
 2. Dividers: Heavy-paper dividers with plastic-covered tabs for each section. Mark each tab to indicate contents. Include typed list of products and major components of equipment included in the section on each divider, cross-referenced to Specification Section number and title of Project Manual.
 3. Protective Plastic Sleeves: Transparent plastic sleeves designed to enclose diagnostic software diskettes for computerized electronic equipment.
 4. Supplementary Text: Prepared on 8-1/2-by-11-inch, 20-lb/sq. ft. white bond paper.

5. Drawings: Attach reinforced, punched binder tabs on drawings and bind with text.
 - a. If oversize drawings are necessary, fold drawings to same size as text pages and use as foldouts.
 - b. If drawings are too large to be used as foldouts, fold and place drawings in labeled envelopes and bind envelopes in rear of manual. At appropriate locations in manual, insert typewritten pages indicating drawing titles, descriptions of contents, and drawing locations.

2.3 EMERGENCY MANUALS

- A. Content: Organize manual into a separate section for each of the following:
 1. Type of emergency.
 2. Emergency instructions.
 3. Emergency procedures.
- B. Type of Emergency: Where applicable for each type of emergency indicated below, include instructions and procedures for each system, subsystem, piece of equipment, and component:
 1. Fire.
 2. Flood.
 3. Gas leak.
 4. Water leak.
 5. Power failure.
 6. Water outage.
 7. System, subsystem, or equipment failure.
 8. Chemical release or spill.
- C. Emergency Instructions: Describe and explain warnings, trouble indications, error messages, and similar codes and signals. Include responsibilities of Owner's operating personnel for notification of Installer, supplier, and manufacturer to maintain warranties.
- D. Emergency Procedures: Include the following, as applicable:
 1. Instructions on stopping.
 2. Shutdown instructions for each type of emergency.
 3. Operating instructions for conditions outside normal operating limits.
 4. Required sequences for electric or electronic systems.
 5. Special operating instructions and procedures.

2.4 OPERATION MANUALS

- A. Content: In addition to requirements in this Section, include operation data required in individual Specification Sections and the following information:
 1. System, subsystem, and equipment descriptions.
 2. Performance and design criteria if Contractor is delegated design responsibility.

3. Operating standards.
4. Operating procedures.
5. Operating logs.
6. Wiring diagrams.
7. Control diagrams.
8. Piped system diagrams.
9. Precautions against improper use.
10. License requirements including inspection and renewal dates.

B. Descriptions: Include the following:

1. Product name and model number.
2. Manufacturer's name.
3. Equipment identification with serial number of each component.
4. Equipment function.
5. Operating characteristics.
6. Limiting conditions.
7. Performance curves.
8. Engineering data and tests.
9. Complete nomenclature and number of replacement parts.

C. Operating Procedures: Include the following, as applicable:

1. Startup procedures.
2. Equipment or system break-in procedures.
3. Routine and normal operating instructions.
4. Regulation and control procedures.
5. Instructions on stopping.
6. Normal shutdown instructions.
7. Seasonal and weekend operating instructions.
8. Required sequences for electric or electronic systems.
9. Special operating instructions and procedures.

D. Systems and Equipment Controls: Describe the sequence of operation, and diagram controls as installed.

E. Piped Systems: Diagram piping as installed, and identify color-coding where required for identification.

2.5 PRODUCT MAINTENANCE MANUAL

A. Content: Organize manual into a separate section for each product, material, and finish. Include source information, product information, maintenance procedures, repair materials and sources, and warranties and bonds, as described below.

B. Source Information: List each product included in manual, identified by product name and arranged to match manual's table of contents. For each product, list name, address, and telephone number of Installer or supplier and maintenance service agent, and cross-reference Specification Section number and title in Project Manual.

- C. Product Information: Include the following, as applicable:
 - 1. Product name and model number.
 - 2. Manufacturer's name.
 - 3. Color, pattern, and texture.
 - 4. Material and chemical composition.
 - 5. Reordering information for specially manufactured products.

- D. Maintenance Procedures: Include manufacturer's written recommendations and the following:
 - 1. Inspection procedures.
 - 2. Types of cleaning agents to be used and methods of cleaning.
 - 3. List of cleaning agents and methods of cleaning detrimental to product.
 - 4. Schedule for routine cleaning and maintenance.
 - 5. Repair instructions.

- E. Repair Materials and Sources: Include lists of materials and local sources of materials and related services.

- F. Warranties and Bonds: Include copies of warranties and bonds and lists of circumstances and conditions that would affect validity of warranties or bonds.
 - 1. Include procedures to follow and required notifications for warranty claims.

2.6 SYSTEMS AND EQUIPMENT MAINTENANCE MANUAL

- A. Content: For each system, subsystem, and piece of equipment not part of a system, include source information, manufacturers' maintenance documentation, maintenance procedures, maintenance and service schedules, spare parts list and source information, maintenance service contracts, and warranty and bond information, as described below.

- B. Source Information: List each system, subsystem, and piece of equipment included in the manual, identified by product name and arranged to match manual's table of contents. For each product, list name, address, and telephone number of Installer or supplier and maintenance service agent, and cross-reference Specification Section number and title in Project Manual.

- C. Manufacturers' Maintenance Documentation: Manufacturers' maintenance documentation including the following information for each component part or piece of equipment:
 - 1. Standard printed maintenance instructions and bulletins.
 - 2. Drawings, diagrams, and instructions required for maintenance, including disassembly and component removal, replacement, and assembly.
 - 3. Identification and nomenclature of parts and components.
 - 4. List of items recommended to be stocked as spare parts.

- D. Maintenance Procedures: Include the following information and items that detail essential maintenance procedures:
 - 1. Test and inspection instructions.
 - 2. Troubleshooting guide.
 - 3. Precautions against improper maintenance.
 - 4. Disassembly; component removal, repair, and replacement; and reassembly instructions.
 - 5. Aligning, adjusting, and checking instructions.
 - 6. Demonstration and training videotape, if available.
- E. Maintenance and Service Schedules: Include service and lubrication requirements, list of required lubricants for equipment, and separate schedules for preventive and routine maintenance and service with standard time allotment.
 - 1. Scheduled Maintenance and Service: Tabulate actions for daily, weekly, monthly, quarterly, semiannual, and annual frequencies.
 - 2. Maintenance and Service Record: Include manufacturers' forms for recording maintenance.
- F. Spare Parts List and Source Information: Include lists of replacement and repair parts, with parts identified and cross-referenced to manufacturers' maintenance documentation and local sources of maintenance materials and related services.
- G. Warranties and Bonds: Include copies of warranties and bonds and lists of circumstances and conditions that would affect validity of warranties or bonds.
 - 1. Include procedures to follow and required notifications for warranty claims.

PART 3 - EXECUTION

3.1 MANUAL PREPARATION

- A. Operation and Maintenance Documentation Directory: Prepare a separate manual that provides an organized reference to emergency, operation, and maintenance manuals.
- B. Emergency Manual: Assemble a complete set of emergency information indicating procedures for use by emergency personnel and by Owner's operating personnel for types of emergencies indicated.
- C. Product Maintenance Manual: Assemble a complete set of maintenance data indicating care and maintenance of each product, material, and finish incorporated into the Work.

- D. Operation and Maintenance Manuals: Assemble a complete set of operation and maintenance data indicating operation and maintenance of each system, subsystem, and piece of equipment not part of a system.
 - 1. Engage a factory-authorized service representative to assemble and prepare information for each system, subsystem, and piece of equipment not part of a system.
 - 2. Prepare a separate manual for each system and subsystem, in the form of an instructional manual for use by Owner's operating personnel.

- E. Manufacturers' Data: Where manuals contain manufacturers' standard printed data, include only sheets pertinent to product or component installed. Mark each sheet to identify each product or component incorporated into the Work. If data include more than one item in a tabular format, identify each item using appropriate references from the Contract Documents. Identify data applicable to the Work and delete references to information not applicable.
 - 1. Prepare supplementary text if manufacturers' standard printed data are not available and where the information is necessary for proper operation and maintenance of equipment or systems.

- F. Drawings: Prepare drawings supplementing manufacturers' printed data to illustrate the relationship of component parts of equipment and systems and to illustrate control sequence and flow diagrams. Coordinate these drawings with information contained in Record Drawings to ensure correct illustration of completed installation.
 - 1. Do not use original Project Record Documents as part of operation and maintenance manuals.
 - 2. Comply with requirements of newly prepared Record Drawings in Division 01 Section "Project Record Documents."

- G. Comply with Division 01 Section "Closeout Procedures" for the schedule for submitting operation and maintenance documentation.

END OF SECTION 017823

SECTION 017839 - PROJECT RECORD DOCUMENTS

PART 1 - GENERAL

1.1 RELATED DOCUMENTS

- A. Drawings and general provisions of the Contract, including General and Supplementary Conditions and other Division 01 Specification Sections, apply to this Section.

1.2 SUMMARY

- A. Section includes administrative and procedural requirements for Project Record Documents, including the following:
 - 1. Record Drawings.
 - 2. Miscellaneous record submittals.
- B. Related Requirements:
 - 1. Division 01 Section "Closeout Procedures" for general closeout procedures and electronic closeout documentation.
 - 2. Division 01 Section "Maintenance Data" for operation and maintenance manual requirements.
 - 3. Divisions 02 through 48 Sections for specific requirements for Project Record Documents of the Work in those Sections.

1.3 CLOSEOUT SUBMITTALS

- A. Record Drawings: Comply with the following:
 - 1. Number of Copies: Submit copies of record Drawings as follows:
 - a. Submit PDF electronic files of scanned marked-up record prints and one of file prints.
- B. Miscellaneous Record Submittals: See other Specification Sections for miscellaneous record-keeping requirements and submittals in connection with various construction activities. Submit annotated PDF electronic files and directories of each submittal.

PART 2 - PRODUCTS

2.1 RECORD DRAWINGS

- A. Record Prints: Maintain one set of marked-up paper copies of the Contract Drawings and Shop Drawings, incorporating new and revised drawings as modifications are issued.
1. Preparation: Mark record prints to show the actual installation where installation varies from that shown originally. Require individual or entity who obtained record data, whether individual or entity is Installer, subcontractor, or similar entity, to provide information for preparation of corresponding marked-up record prints.
 - a. Give particular attention to information on concealed elements that would be difficult to identify or measure and record later.
 - b. Accurately record information in an acceptable drawing technique.
 - c. Record data as soon as possible after obtaining it.
 - d. Record and check the markup before enclosing concealed installations.
 - e. Cross-reference record prints to corresponding archive photographic documentation.
 2. Content: Types of items requiring marking include, but are not limited to, the following:
 - a. Dimensional changes to Drawings.
 - b. Revisions to details shown on Drawings.
 - c. Changes made by Change Order or Construction Change Directive.
 - d. Changes made following Architect's written orders.
 - e. Details not on the original Contract Drawings.
 - f. Field records for variable and concealed conditions.
 - g. Record information on the Work that is shown only schematically.
 3. Mark the Contract Drawings or Shop Drawings, whichever is most capable of showing actual physical conditions, completely and accurately. If Shop Drawings are marked, show cross-reference on the Contract Drawings.
 4. Mark record sets with red-colored lines. Use other colors to distinguish between changes for different categories of the Work at same location.
 5. Mark important additional information that was either shown schematically or omitted from original Drawings.
 6. Note Construction Change Directive numbers, alternate numbers, Change Order numbers, and similar identification, where applicable.
- B. Record Digital Data Files: Immediately before inspection for Certificate of Substantial Completion, review marked-up record prints with Architect. When authorized, prepare a full set of corrected digital data files of the Contract Drawings, as follows:
1. Format: Annotated PDF electronic file with comment function enabled.
 2. Incorporate changes and additional information previously marked on record prints. Delete, redraw, and add details and notations where applicable.
 3. Refer instances of uncertainty to Architect for resolution.

4. Architect will furnish Contractor one set of digital data files of the Contract Drawings for use in recording information.
 - a. See Section 013300 "Submittal Procedures" for requirements related to use of Architect's digital data files.
 - b. Architect will provide data file layer information. Record markups in separate layers.
- C. Format: Identify and date each Record Drawing; include the designation "PROJECT RECORD DRAWING" in a prominent location.
 1. Record Prints: Organize Record Prints and newly prepared Record Drawings into manageable sets. Bind each set with durable paper cover sheets. Include identification on cover sheets.
 2. Identification: As follows:
 - a. Project name.
 - b. Date.
 - c. Designation "PROJECT RECORD DRAWINGS."
 - d. Name of Architect.
 - e. Name of Contractor.

2.2 MISCELLANEOUS RECORD SUBMITTALS

- A. Assemble miscellaneous records required by other Specification Sections for miscellaneous record keeping and submittal in connection with actual performance of the Work. Bind or file miscellaneous records and identify each, ready for continued use and reference.
- B. Format: Submit miscellaneous record submittals as PDF electronic file scanned PDF electronic file(s) of marked-up miscellaneous record submittals.
 1. Include miscellaneous record submittals directory organized by Specification Section number and title, electronically linked to each item of miscellaneous record submittals.

PART 3 - EXECUTION

3.1 RECORDING AND MAINTENANCE

- A. Recording: Maintain one copy of each submittal during the construction period for Project Record Document purposes. Post changes and modifications to Project Record Documents as they occur; do not wait until the end of Project.
- B. Maintenance of Record Documents: Store Record Documents in the field office apart from the Contract Documents used for construction. Do not use Project Record Documents for construction purposes. Maintain Record Documents in good order and

in a clean, dry, legible condition, protected from deterioration and loss. Provide access to Project Record Documents for Architect's reference during normal working hours.

END OF SECTION 017839

SECTION 017900 - DEMONSTRATION AND TRAINING

PART 1 - GENERAL

1.1 RELATED DOCUMENTS

- A. Drawings and general provisions of the Contract, including General and Supplementary Conditions and other Division 01 Specification Sections, apply to this Section.

1.2 SUMMARY

- A. Section includes administrative and procedural requirements for instructing Owner's personnel, including the following:
 - 1. Demonstration of operation of systems, subsystems, and equipment.
 - 2. Training in operation and maintenance of systems, subsystems, and equipment.
 - 3. Demonstration and training digital video recordings.
- B. Related Requirements:
 - 1. Division 01 Section "Project Management and Coordination" for requirements for pre-instruction conferences.
 - 2. Divisions 02 through 48 Sections for specific requirements for demonstration and training for products in those Sections.

1.3 COORDINATION

- A. Coordinate instruction schedule with Owner's operations. Adjust schedule as required to minimize disrupting Owner's operations.
- B. Coordinate instructors, including providing notification of dates, times, length of instruction time, and course content.
- C. Coordinate content of training modules with content of approved emergency, operation, and maintenance manuals. Do not begin training until operation and maintenance data has been reviewed and approved by Architect.

1.4 SUBMITTALS

- A. Instruction Program: Submit two copies of outline of instructional program for demonstration and training, including a schedule of proposed dates, times, length of instruction time, and instructors' names for each training module. Include learning objective and outline for each training module.
 - 1. At completion of training, submit one complete training manual(s) for Owner's use.
- B. Attendance Record: For each training module, submit list of participants and length of instruction time.
- C. Demonstration and Training Digital Recording DVD's: Submit two copies within seven days of end of each training module.
 - 1. Identification: On each copy, provide an applied label with the following information:
 - a. Name of Project.
 - b. Name of Architect and Construction Manager.
 - c. Name of Contractor.
 - d. Date digital video was recorded.
 - e. Description of vantage point, indicating location, direction (by compass point), and elevation or story of construction.

1.5 QUALITY ASSURANCE

- A. Instructor Qualifications: A factory-authorized service representative, complying with requirements in Division 01 Section "Quality Requirements," experienced in operation and maintenance procedures and training.

PART 2 - PRODUCTS

2.1 INSTRUCTION PROGRAM

- A. Program Structure: Develop an instruction program that includes individual training modules for each system and equipment not part of a system, as required by individual Specification Sections.
- B. Training Modules: For each module, include instruction for the following:
 - 1. Basis of System Design, Operational Requirements, and Criteria: Include the following:
 - a. System, subsystem, and equipment descriptions.
 - b. Performance and design criteria if Contractor is delegated design responsibility.
 - c. Operating standards.

- d. Regulatory requirements.
 - e. Equipment function.
 - f. Operating characteristics.
 - g. Limiting conditions.
 - h. Performance curves.
2. Documentation: Review the following items in detail:
- a. Emergency manuals.
 - b. Operations manuals.
 - c. Maintenance manuals.
 - d. Project Record Documents.
 - e. Identification systems.
 - f. Warranties and bonds.
 - g. Maintenance service agreements and similar continuing commitments.
3. Emergencies: Include the following, as applicable:
- a. Instructions on meaning of warnings, trouble indications, and error messages.
 - b. Instructions on stopping.
 - c. Shutdown instructions for each type of emergency.
 - d. Operating instructions for conditions outside of normal operating limits.
 - e. Sequences for electric or electronic systems.
 - f. Special operating instructions and procedures.
4. Operations: Include the following, as applicable:
- a. Startup procedures.
 - b. Equipment or system break-in procedures.
 - c. Routine and normal operating instructions.
 - d. Regulation and control procedures.
 - e. Control sequences.
 - f. Safety procedures.
 - g. Instructions on stopping.
 - h. Normal shutdown instructions.
 - i. Operating procedures for emergencies.
 - j. Operating procedures for system, subsystem, or equipment failure.
 - k. Seasonal and weekend operating instructions.
 - l. Required sequences for electric or electronic systems.
 - m. Special operating instructions and procedures.
5. Adjustments: Include the following:
- a. Alignments.
 - b. Checking adjustments.
 - c. Noise and vibration adjustments.
 - d. Economy and efficiency adjustments.

6. Troubleshooting: Include the following:
 - a. Diagnostic instructions.
 - b. Test and inspection procedures.

7. Maintenance: Include the following:
 - a. Inspection procedures.
 - b. Types of cleaning agents to be used and methods of cleaning.
 - c. List of cleaning agents and methods of cleaning detrimental to product.
 - d. Procedures for routine cleaning
 - e. Procedures for preventive maintenance.
 - f. Procedures for routine maintenance.
 - g. Instruction on use of special tools.

8. Repairs: Include the following:
 - a. Diagnosis instructions.
 - b. Repair instructions.
 - c. Disassembly; component removal, repair, and replacement; and reassembly instructions.
 - d. Instructions for identifying parts and components.
 - e. Review of spare parts needed for operation and maintenance.

PART 3 - EXECUTION

3.1 PREPARATION

- A. Assemble educational materials necessary for instruction, including documentation and training module. Assemble training modules into a combined training manual.
- B. Set up instructional equipment at instruction location.

3.2 INSTRUCTION

- A. Engage qualified instructors to instruct Owner's personnel to adjust, operate, and maintain systems, subsystems, and equipment not part of a system.
 1. Owner will furnish Contractor with names and positions of participants.
- B. Scheduling: Provide instruction at mutually agreed on times. For equipment that requires seasonal operation, provide similar instruction at start of each season.
 1. Schedule training with Owner, through Construction Manager, with at least seven days' advance notice.
- C. Cleanup: Collect used and leftover educational materials and remove from Project site. Remove instructional equipment. Restore systems and equipment to condition existing before initial training use.

3.3 DEMONSTRATION AND TRAINING DIGITAL VIDEO RECORDINGS

- A. General: Where required in Divisions 02 through 48 Sections, record demonstration and training digital video disks. Record each training module separately. Include classroom instructions and demonstrations, board diagrams, and other visual aids, but not student practice.
 - 1. At beginning of each training module, record learning objective.
- B. Digital Video Recording Format: Provide high-quality color DVD's.
- C. Recording: Mount camera on tripod before starting recording, unless otherwise necessary to show area of demonstration and training. Display continuous running time.
- D. Narration: Describe scenes on digital video recording by audio narration by microphone while digital video is recorded. Include description of items being viewed. Describe vantage point, indicating location, direction (by compass point), and elevation or story of construction.

END OF SECTION 017900

SECTION 019113 - GENERAL COMMISSIONING REQUIREMENTS

PART 1 - GENERAL

1.1 RELATED DOCUMENTS

- A. Drawings and general provisions of the Contract, including General and Supplementary Conditions and other Division 01 Specification Sections, apply to this Section.
- B. OPR and BoD documentation are included by reference for information only.

1.2 SUMMARY

- A. Section includes general requirements that apply to implementation of commissioning without regard to specific systems, assemblies, or components.

1.3 DEFINITIONS

- A. BoD: Basis of Design. A document that records concepts, calculations, decisions, and product selections used to meet the OPR and to satisfy applicable regulatory requirements, standards, and guidelines. The document includes both narrative descriptions and lists of individual items that support the design process.
- B. Commissioning Plan: A document that outlines the organization, schedule, allocation of resources, and documentation requirements of the commissioning process.
- C. CxA: Commissioning Authority.
- D. OPR: Owner's Project Requirements. A document that details the functional requirements of a project and the expectations of how it will be used and operated. These include Project goals, measurable performance criteria, cost considerations, benchmarks, success criteria, and supporting information.
- E. Systems, Subsystems, Equipment, and Components: Where these terms are used together or separately, they shall mean "as-built" systems, subsystems, equipment, and components.

1.4 COMMISSIONING TEAM

- A. Members Appointed by Contractor(s): Individuals, each having the authority to act on behalf of the entity he or she represents, explicitly organized to implement the commissioning process through coordinated action. The commissioning team shall consist of, but not be limited to, representatives of each Contractor, including Project superintendent and subcontractors, installers, suppliers, and specialists deemed appropriate by the CxA.

B. Members Appointed by Owner:

1. CxA: The designated person, company, or entity that plans, schedules, and coordinates the commissioning team to implement the commissioning process. Owner will engage the CxA under a separate contract.
2. Representatives of the facility user and operation and maintenance personnel.
3. Architect and engineering design professionals.

1.5 OWNER'S RESPONSIBILITIES

- A. Provide the OPR documentation to the CxA and each Contractor for information and use.
- B. Assign operation and maintenance personnel and schedule them to participate in commissioning team activities.
- C. Provide the BoD documentation, prepared by Architect and approved by Owner, to the CxA and each Contractor for use in developing the commissioning plan, systems manual, and operation and maintenance training plan.

1.6 EACH CONTRACTOR'S RESPONSIBILITIES

- A. Each Contractor shall assign representatives with expertise and authority to act on its behalf and shall schedule them to participate in and perform commissioning process activities including, but not limited to, the following:
 1. Evaluate performance deficiencies identified in test reports and, in collaboration with entity responsible for system and equipment installation, recommend corrective action.
 2. Cooperate with the CxA for resolution of issues recorded in the Issues Log.
 3. Attend commissioning team meetings held on a weekly basis.
 4. Integrate and coordinate commissioning process activities with construction schedule.
 5. Review and accept construction checklists provided by the CxA.
 6. Complete paper or electronic construction checklists as Work is completed and provide to the Commissioning Authority at the interval requested by the Commissioning Authority.
 7. Review and accept commissioning process test procedures provided by the Commissioning Authority.
 8. Complete commissioning process test procedures.

1.7 CxA'S RESPONSIBILITIES

- A. Organize and lead the commissioning team.
- B. Provide commissioning plan.
- C. Convene commissioning team meetings.

- D. Provide Project-specific construction checklists and commissioning process test procedures.
- E. Verify the execution of commissioning process activities using random sampling. The sampling rate may vary from 1 to 100 percent. Verification will include, but is not limited to, equipment submittals, construction checklists, training, operating and maintenance data, tests, and test reports to verify compliance with the OPR. When a random sample does not meet the requirement, the CxA will report the failure in the Issues Log.
- F. Prepare and maintain the Issues Log.
- G. Prepare and maintain completed construction checklist log.
- H. Witness systems, assemblies, equipment, and component startup.
- I. Compile test data, inspection reports, and certificates; include them in the systems manual and commissioning process report.

PART 2 - PRODUCTS (Not Used)

PART 3 - EXECUTION (Not Used)

END OF SECTION 019113

SECTION 271000 – COMMON WORK RESULTS FOR COMMUNICATIONS CABLING SYSTEMS

PART 1 - GENERAL

1.1 RELATED DOCUMENTS

- A. Drawings (“associated project drawings”) and general provisions of the Contract, including General and Supplementary Conditions and other Division 01 Specification Sections, apply to this Section.

1.2 SUMMARY

- A. This section includes general administrative and procedural requirements governing execution of the Work including, but not limited to, the following:
 - 1. Common work results for communications cabling systems
 - 2. Firestopping for communications cabling systems
- B. Related Sections:
 - 1. Division 01 Sections pertaining to project management, coordination, jobsite safety and requirements, operation and maintenance requirements, and closeout procedures.
 - 2. Division 26 Sections related to raceways, conduits, and electrical boxes.

1.3 DEFINITIONS

- A. AVIC: Audiovisual Installation Contractor
- B. CIC: Cabling Installation Contractor
- C. GC: General Contractor
- D. EC: Electrical Installation Contractor
- E. MEP: Mechanical, Electrical, and Plumbing
- F. PIC: Paging Installation Contractor
- G. SIC: Security Installation Contractor

1.4 SCOPE

- A. The new communications cabling system shall be capable of supporting voice, data, and video requirements at and beyond 1000 Mbps.
- B. All cable, associated materials and labor required for a complete installation of the communications cabling system shall be provided by the CIC unless otherwise stated in this document.
- C. The CIC shall remove all previously installed and abandoned cable before the installation of new cabling takes place. This may consist of abandoned communications cabling not removed during demolition as well as any temporary cabling installed by the CIC as part of the installation.
- D. Due care and diligence have been used in preparation of this information, and it is believed to be substantially correct. However, the responsibility for determining the full extent of exposure and the verification of all information presented herein shall rest solely with the CIC. The owner, Sentinel Technologies, and any other representatives will not be responsible for any errors or omissions in these specifications, nor for the failure on the part of the CIC to determine the full extent of the exposures.
- E. The CIC shall not be allowed to take advantage of any errors or omissions in these specifications and associated project drawings. Where errors or omissions appear in these specifications or

drawings, the CIC shall promptly notify Sentinel Technologies in writing of such errors or omissions. Any significant errors, omissions, or inconsistencies in the specifications shall be reported no later than five (5) days before the submission deadline. The owner, Sentinel Technologies, and any other representatives will not be responsible for errors that go undiscovered.

1.5 DRAWINGS

- A. Associated drawings are diagrammatic in nature and may not represent exact field conditions. The CIC shall field-verify critical installation requirements and provide necessary associated work.
- B. The locations of telecommunication equipment and devices shown are approximate. The CIC shall, prior to installation, verify exact locations by cross-checking architectural and electrical drawings, field conditions and approved shop drawings.
- C. The CIC shall be prepared to relocate equipment or devices provided under this scope of work when directed by the project team without cost, provided equipment has not been installed and the new location is not greater than twenty five feet (25') from the location originally shown.
- D. Outlets shall be located at same height, and of same orientation, unless otherwise noted.
- E. Wiring, signal and control devices, where provided, shall be flush-mounted in finished areas.

1.6 SUBMITTALS

- A. Upon award of the project, shop drawings and product data of standard cataloged products shall be submitted with applicable data that meet the job requirements. Submittals that include information on multiple devices or equipment are acceptable only when items applicable to the job are identified with arrows, check marks or other call outs. The CIC shall clearly identify which manufacturer solutions are being proposed at the time of bid response.
- B. When shop drawings are created from or incorporated with Sentinel's drawings, the CIC shall remove the architect's, engineer's, and Sentinel's title blocks and replace it with the CIC's own, unique title block. The CIC's title block shall include, at a minimum, the CIC's name, address and telephone number, and the project name.
- C. Shop drawings of related equipment, devices and material shall be submitted at same time so the project team can coordinate the related components.
- D. No material or equipment shall be released for manufacture or shipment without first obtaining the approval of the project team. Only the CIC shall be responsible for costs and coordination of returning items purchased prior to approval.
- E. The CIC shall submit an electronic copy of the submittals unless directed otherwise by the GC or the owner. These submittals may be subject to approval, or rejection with commentary. Submittals may consist of but not be limited to one or any appropriate combination of the following:
 - 1. Manufacturer cut-sheets
 - 2. Shop drawings (including single-line diagrams)
 - 3. Catalog sheets
 - 4. Written specifications
 - 5. Originals or copies of the above
- F. If hard copies of the submittals are requested, they should be bound in a standard three-ring binder with a minimum of the CIC's name, address and telephone number, and the project name.

1.7 QUALITY ASSURANCE

- A. All materials and labor provided by the CIC shall be of the highest quality.

- B. The CIC shall be certified to install the solution that the CIC has proposed as specified in this document.
- C. Only the highest grade components shall be considered, and all components shall be balanced with each other from an electrical and performance characteristic standpoint.
- D. The communications cabling system shall be end-to-end certified by the CIC and the manufacturer. A written document addressing the communication cabling system's certification shall be provided by the manufacturer once the installation is complete.
- E. All work shall be performed in a workmanlike manner according to generally accepted trade practices.
- F. Appropriate union requirements shall be strictly followed and all CIC employees on site shall have appropriate union licenses.
- G. All work to be performed by the CIC shall be coordinated with the other trades and the General Contractor.
- H. The CIC shall conform and adhere to all job site requirements as defined by the General Contractor. It is the responsibility of the CIC to obtain these requirements from the General Contractor.
- I. All necessary permits are to be secured by the CIC.
- J. Appropriate levels of insurance and bonding shall be maintained. Certificates of Insurance may be requested, and shall be provided at the CIC's expense.
- K. Any variations to the installation of the communications cabling system as described in this specification and the associated project drawings shall be subject to the control and approval of the architect, the owner and Sentinel.
- L. Substitution of any materials specified in this document shall only be considered once a request to do so has been submitted in writing to the architect, the owner, and Sentinel for prior approval. This submittal shall discuss the scope of the change, the ramifications on the overall communications cabling system and the advantages to be gained by the owner.
- M. The CIC shall conform to the following standards when provisioning and installing the new communications cabling system:
 - 1. All applicable local, county and state building and electrical codes with local addenda
 - 2. Building Industry Consulting Services International (BICSI) *Information Transport Systems Installation Manual* (Latest Edition)
 - 3. Building Industry Consulting Services International (BICSI) *Telecommunications Distribution Methods Manual* (TDMM) (Latest Edition)
 - 4. NFPA 70 *National Electrical Code* (NEC) 2020 (where more stringent than local codes)
 - 5. UL 444 2008, Communication Cables
 - 6. ANSI/NECA/BICSI 568-2006, Standard For Installing Commercial Building Telecommunications Cabling
 - 7. ANSI/TIA-568.0-D, Generic Telecommunications Cabling For Customer Premises
 - 8. FCC Part 68 Regulations
 - 9. ANSI/TIA-568.1-D, Commercial Building Telecommunications Cabling Standard
 - 10. IEEE 802.3, Ethernet Standard
 - 11. ANSI/TIA-568.2-D, Balanced Twisted-Pair Telecommunications Cabling And Components Standard
 - 12. ANSI/TIA-569-D, Telecommunications Pathways And Spaces

13. ANSI/TIA-606-C, Administration Standard For Commercial Telecommunications Infrastructure
14. ANSI/TIA-607-C-1, Generic Telecommunications Bonding And Grounding (Earthing) For Customer Premises
15. ANSI/BICSI-607, Standard For Telecommunications Bonding And Grounding Planning And Installation Methods For Commercial Buildings
16. ANSI/TIA-1152-A, Requirements For Field Test Instruments And Measurements For Balanced Twisted-Pair Cabling
17. ANSI/BICSI 001-2017, Information Transport Systems Design Standard For K-12 Educational Institutions
18. ANSI/TIA-568.3-D, Optical Fiber Cabling and Components Standard
19. TIA-526-14-C, Optical Power Loss Measurements Of Installed Multimode Fiber Cable Plant

N. First-Named Manufacturer

1. Within these specifications and associated drawings, the first-named approved manufacturer indicates that its respective device, equipment or system may have been used to meet the job requirements and to determine the space and dimensional requirements. The CIC's use of another pre-approved system may require that the CIC verify that the respective devices, equipment, systems or products will meet the job requirements and will fit the allocated space.
2. The listing of a manufacturer as acceptable or pre-approved does not in any way relieve the CIC from the responsibility for providing devices, equipment or systems that meet the requirements of the specifications. The CIC shall verify that performance requirements are met, as no two manufacturers should be trusted as exactly identical in function, fit, or finish.

1.8 COORDINATION

- A. The CIC shall coordinate the arrangement, installation, and finishing of the communications cabling system.
 1. All faceplate colors and finishes shall be coordinated with the architect.
 2. Any conduit, pathway, or sleeve requirements shall be coordinated with the MEP engineer.
 3. The alignment and positioning of pull boxes, junction boxes, back boxes, conduit ends, stubs, sleeves, etc., with CIC-installed raceways, horizontal or vertical trays, racks, and cabinets, etc.
 4. Any equipment cut into, mounted on, or suspended from architectural elements such as walls or ceiling shall be coordinated with the architect to ensure there is no conflict with design intent or functionality.
 5. Any other elements that might or will interfere with elements installed by other trades shall be coordinated with the GC and those respective trades.
 6. Although quantities of patch cords may be detailed later in this document, the CIC shall be responsible for coordinating final quantities, lengths, and colors with the end user's information technology department and Sentinel.
- B. Conflicts requiring noticeable deviation from the associated project drawings or these specifications shall be coordinated with Sentinel.

PART 2 - PRODUCTS

2.1 FIRESTOPPING

- A. Fire stop systems shall be UL-listed or Factory Mutual approved. The CIC shall furnish and install the proper fire stop system with classified products and materials compatible with the appropriate penetrating elements, type of construction material and dimensions of the wall, partition, barrier, or floor, and the environment and temperature range of both sides of the opening. Fire stop systems shall maintain the original fire resistance rating of the wall, partition, barrier, or floor prior to the penetration.
- B. Expansion type fire stop material shall be used where necessary to protect and close the opening upon failure of the penetrating element due to fire.
- C. Fire stop penetrations in fire-rated walls and floors for sleeves, cables, conduits, ducts, and cable trays.
- D. Fire stopping for openings through fire and smoke-rated walls and floor assemblies shall be listed or classified by an approved independent testing laboratory for "Through-Penetration Firestop Systems." The system shall meet the requirements of "Fire Tests of Through-Penetration Firestops" designated ASTM E814.
- E. The CIC shall furnish and install systems fire tested by a third party according to ASTM E814 (or UL 1479) tested under positive pressure.
- F. Provide only material combinations that are qualified by independent agencies based on the material's performance when tested in a particular configuration.
- G. Thickness of materials must be established by formal ASTM E814 or UL 1479 tests.

PART 3 - EXECUTION

3.1 COMMON WORK RESULTS FOR INSTALLATION

- A. Locations and routes of pathways shown on drawings are schematic and not necessarily reflective of conditions at time of installation, or were positioned for clarity rather than exact spacing, bending, or desired separation. The CIC shall review any and all such pathways shown on the drawings to ensure that the proposed solution will function as intended with regard to quantities, sizes, locations, etc.
- B. The CIC shall review the actual conduit plans proposed by the MEP or EC to ensure that conduits intended for the communications cabling system are correctly sized, adequately positioned, and have the requisite number of pull boxes as required by the actual materials proposed by the CIC, and/or as the CIC desires as optimal for installation. The CIC shall be responsible for any and all costs associated with conduit changes resulting from failure to preview and approve the pathways installed by others.
- C. Install all materials in compliance with manufacturer's written directions.
- D. The CIC shall protect all stored or installed materials as part of these systems before, during, or after installation from damage caused by other trades until turnover and final acceptance. If damage occurs despite such protections, remove and replace all damaged components or the entire unit(s) as required to provide a solution in an original, undamaged condition.
- E. Take field measurements as required to fit the Work properly. Recheck measurements before installing each product. Where portions of the Work are indicated to fit to other construction, verify dimensions of other construction by field measurements before fabrication. Coordinate fabrication schedule with construction progress to avoid delaying the Work.
- F. Verify space requirements and dimensions of items shown diagrammatically on the associated project drawings.

- G. Immediately on discovery of the need for clarification of the Contract Documents caused by differing field conditions outside the control of the CIC, submit a request for information to the GC according to the requirements specified in Division 01.

3.2 FIRESTOPPING

- A. The CIC shall install fire stopping material in accordance with construction elements and manufacturer specification.
- B. Thoroughly clean and remove any fire stopping material that drips or falls onto wall or floor surfaces.
- C. After installation, protect the fire stop material from damage during construction. If damage occurs despite such protections, remove and replace fire stopping material as required to restore the integrity of the fire rating.

END OF SECTION

SECTION 271100 – BACKBONE COMMUNICATIONS CABLING

PART 1 - GENERAL

1.1 RELATED DOCUMENTS

- A. Drawings (“associated project drawings”) and general provisions of the Contract, including General and Supplementary Conditions and other Division 01 Specification Sections, apply to this Section.

1.2 SUMMARY

- A. This section includes:
 - 1. Fiber Optic Backbone Cable
 - 2. Fiber Optic Connectors and Panels

1.3 SCOPE

- A. The CIC shall provide all materials, tools, equipment and labor required for the complete installation of the Work called for in the contract documents provided by the architect or Sentinel related to the provision and installation of the owner’s backbone communications cabling.

1.4 SUBMITTALS

- A. Refer to Section 271000, Part 1, Section 1.6, for all submittal requirements.

1.5 COORDINATION

- A. The CIC shall review any and all sleeve, riser conduit, and bushing with the EC prior to installing backbone cabling.
- B. The CIC shall review all applicable building requirements for passing cabling between floors.

PART 2 - PRODUCTS

2.1 FIBER OPTIC BACKBONE CABLE

- A. 50-micron laser-optimized multimode fiber optic cable (OM4-grade) shall be installed to form a fiber optic backbone (refer to associated drawings for quantities and distribution).
- B. All armored fiber optic cable shall be OFCP listed (optical fiber conductive plenum cable) for plenum spaces or OFCR (optical fiber conductive riser cable) for riser systems as specified in NEC section 770-50.
- C. All fiber optic cable shall be from the same manufacturer and be the same type.
- D. All multimode fiber optic cable shall meet or exceed the following requirements:
 - 1. Contain graded-index fibers with a laser-optimized 50-micron core.
 - 2. Support dual wavelength capability for transmitting at the 850nm and 1300nm wavelengths.
 - 3. Meet or exceed the following graded performance:
 - a. A maximum attenuation of 3.5 dB/km and minimum bandwidth of 2,000 MHz/km at the 850 nm wavelength
 - b. A maximum attenuation of 1.5 dB/km and minimum bandwidth of 500 MHz/km at the 1,300 nm wavelength

- E. Only fiber optic cables from the following manufacturers that meet the performance specifications listed above shall be considered:
 - 1. Berk-Tek - PDPK024FB3010/F5
 - 2. Hubbell - HFCD15024P4
 - 3. Uniprise - P-024-DZ-5K-FSUAQ

2.2 FIBER OPTIC CONNECTOR AND PANEL

- A. Fiber optic connectors shall be of the LC type.
- B. Only fiber optic connectors and panels from the following manufacturers shall be considered:
 - 1. Hubbell - FCR1U3SP, FSPNLCDS12AQ
 - 2. Leviton - 5R1UM-S03, 5F100-4QL
 - 3. Uniprise - PNL-BK-024-MFA-LC02-AQ-NS, EPX-1U-PNL-ENC-FX

PART 3 - EXECUTION

3.1 INSTALLATION PROCEDURES

- A. Multimode fiber shall be laser-optimized 50-micron cable (OM4-grade) and shall exceed the most current ANSI/TIA performance specifications (as shown in this specification's overview) unless stated otherwise.
- B. All CIC-installed cable shall be installed above the ceilings using appropriate supports outlined in section 271300.
- C. In distributed telecommunications rooms that are vertically stacked, all CIC-installed cable shall be installed in sleeves or conduits (supplied and installed by others). If sleeves are used, then all cables shall be secured to the wall every forty eight inches (48").
- D. All CIC-installed cable runs shall contain no splice or transition points from cross-connect to cross-connect.
- E. All cables shall be installed such that the respective manufacturers' recommended bend radius for each cable type is not exceeded.
- F. The CIC shall be responsible for verifying the actual distances for each CIC-installed cable run from cross-connect to cross-connect.
- G. All CIC-installed cables shall be properly dressed, tied and trimmed.
- H. Cable pulling lubricants, where used, shall be approved by the cable manufacturer so that the lubricating compounds do not deteriorate the cable jacket.
- I. The CIC shall assume responsibility for any damage to the cable during installation.
- J. The CIC shall test, label and document the backbone cabling as described in section 271700 of this document.

END OF SECTION

SECTION 271200 – HORIZONTAL COMMUNICATIONS CABLING

PART 1 - GENERAL

1.1 RELATED DOCUMENTS

- A. Drawings (“associated project drawings”) and general provisions of the Contract, including General and Supplementary Conditions and other Division 01 Specification Sections, apply to this Section.

1.2 SUMMARY

- A. This section includes:
 - 1. Category 6 UTP cables and connectivity
 - 2. Category 6A (10Gb) cables and connectivity
 - 3. Patch cords

1.3 SCOPE

- A. The CIC shall provide all materials, tools, equipment and labor required for the complete installation of the Work called for in the contract documents provided by the architect or Sentinel related to the provision and installation of the owner’s horizontal and station communications cabling.

1.4 SUBMITTALS

- A. Refer to Section 271000, Part 1, Section 1.6, for all submittal requirements.

1.5 COORDINATION

- A. The CIC shall review any and all conduit, stubs, pull boxes, back boxes, and junction boxes with the EC prior to installing cabling.
- B. The CIC shall confirm final patch cord quantities, colors, and lengths with the owner and Sentinel prior to ordering.

PART 2 - PRODUCTS

2.1 UTP HORIZONTAL STATION CABLE

- A. All UTP cable shall be CMP (communications plenum cable) for plenum spaces as specified in NEC Section 800-50.
- B. All UTP cable shall be from the same manufacturer and be the same type.
- C. All Category 6 UTP cable and connectors shall meet or exceed the channel requirements as defined by the latest standard referenced in Section 271000, Part 1, Subsection M (the CIC should be aware that all testing requirements will be for the permanent link).
- D. All Category 6A (10Gb) UTP cable and connectors shall meet or exceed the channel requirements as defined by the latest standard referenced in Section 271000, Part 1, Subsection M (the CIC should be aware that all testing requirements will be for the permanent link).
- E. Only UTP cables from the following manufacturers that meet the performance specifications listed above shall be considered:
 - 1. Berk-Tek – 10032092, 11141651
 - 2. Hubbell - C6ASPDSW, HC6RPW

3. Uniprise - CS37P WHT C6 4/23 U/UTP CPK 1KFT, CS44P WHT C6A 4/23 U/UTP CPK 1KFT

2.2 UTP CONNECTOR

- A. Category 6 8P8C (RJ45) and Category 6A (10Gb) 8P8C (RJ45) connectors shall be used.
- B. Only UTP connectors from the following manufacturers that meet the performance specifications listed above shall be considered:
 1. Hubbell - HJU6X, HXJ6X, HPJ24, HPJ48
 2. Leviton - 49255-H24, 6110G-RX6, 49255-H48, 61110-RX6
 3. Uniprise - CPP-UDDM-SL-1U-24, UNJ10G-XX, CPP-UDDM-SL-2U-48, UNJ600-XX

2.3 PATCH CORDS

- A. The CIC shall provide a budget to provide and install all necessary UTP and fiber optic patch cords unless directed otherwise by the owner or Sentinel. For purposes of the bid response provided one (1) 7-foot patch cord at the faceplate and one (1) 7-foot patch cord at the patch panel for each location shown on the drawings. In addition, provide twenty (20) 2-meter OM4 grade 50-micron fiber optic patch cords with LC connectors.
- B. UTP patch cords shall be blue in color unless directed otherwise by the owner or Sentinel.
- C. All patch cords shall be pre-manufactured and tested at the factory by the same manufacturer that supplied the communications cabling system: field construction of these patch cords is not acceptable.

PART 3 - EXECUTION

3.1 HORIZONTAL COMMUNICATIONS CABLING SYSTEM

- A. All CIC-installed horizontal cable runs shall contain no splice or transition points from the cross-connect to each outlet location.
- B. The CIC shall coordinate with the architect the exact color and orientation and placement of all faceplates before any components are purchased and installed.
- C. The CIC shall provide and install all jacks and appropriate inserts for all locations, including those inside floor, table-top boxes, and modular furniture systems.
- D. The jacks shall correspond to the following colors at the faceplate and the patch panel:
 1. Wireless Access Points – Blue
 2. Wall/Floor Data Locations – White
 3. Camera Locations – Orange
 4. Projector Locations – Yellow
 5. Paging Speaker/Clock Locations - Green
- E. Refer to the associated project drawings for the outlet types and their configurations.
- F. All faceplates shall be installed level to within one-sixteenth of an inch of true; the CIC shall verify faceplates with a torpedo level to ensure faceplates are not visibly crooked.
- G. All UTP cable and connecting hardware shall be rated as Category 6 and shall exceed the most current ANSI/TIA performance specifications for Category 6 permanent link (as shown in this specification's overview) unless stated otherwise.
- H. All UTP cable and connecting hardware for wireless access point locations shall be rated as Category 6A (10Gb) and shall exceed the most current ANSI/TIA performance specifications for

Category 6A (10Gb) permanent link (as shown in this specification's overview) unless stated otherwise.

- I. Multimode fiber shall be laser-optimized 50-micron cable (OM4-grade) and shall exceed the most current ANSI/TIA specifications (as shown in this specification's overview) unless stated otherwise.
- J. The T568B wiring pattern shall be used for all UTP cable terminations.
- K. All CIC-installed cable shall be installed above the ceilings using appropriate supports outlined in section 271300.
- L. In distributed telecommunications rooms that are vertically stacked, all fiber optic, UTP and coaxial cable shall be installed in sleeves or conduits (supplied and installed by others). If sleeves are used, then all cables shall be secured to the wall every 48-forty eight inches (48").
- M. All cables shall be installed such that the recommended bend radius for each cable type is not exceeded.
- N. The CIC shall be responsible for verifying the actual distances for each CIC-installed cable run from the cross-connect to each outlet location.
- O. All CIC-installed cables shall be properly dressed, tied and trimmed.
- P. Cable pulling lubricants, where used, shall be approved by the cable manufacturer so that the lubricating compounds do not deteriorate the cable jacket.
- Q. The CIC shall assume responsibility for any damage to the cable during installation.
- R. The CIC shall test, label and document the horizontal cabling as described in section 271700 of this document.

END OF SECTION

SECTION 271300 – INTERIOR COMMUNICATIONS PATHWAYS

PART 1 - GENERAL

1.1 RELATED DOCUMENTS

- A. Drawings (“associated project drawings”) and general provisions of the Contract, including General and Supplementary Conditions and other Division 01 Specification Sections, apply to this Section.

1.2 SUMMARY

- A. This section includes:
 - 1. Other supports

1.3 SCOPE

- A. The CIC shall provide all materials, tools, equipment and labor required for the complete installation of the Work called for in the contract documents provided by the architect or Sentinel related to the routing and interior pathways of all cabling within the building.

1.4 SUBMITTALS

- A. Refer to Section 271000, Part 1, Section 1.6, for all submittal requirements.

1.5 COORDINATION

- A. The CIC shall review any and all pathways to identify areas or locations where there may be conflict with other trades, particularly architectural, mechanical, electrical, plumbing, or fire protection-related.
- B. The CIC shall coordinate all cable tray installation with the architects, MEP engineers and the other trades on the project.

PART 2 - PRODUCTS

2.1 OTHER SUPPORTS

- A. Bridle rings or other equivalent supports shall be installed in areas where ducts, conduits or cable trays are not available.

PART 3 - EXECUTION

3.1 OTHER SUPPORTS

- A. J-hangers, J-hooks or other equivalent supports shall be installed at a minimum of every three to four feet (3-4’).
- B. The CIC shall assume responsibility for any damage to the bridle rings or other equivalent supports during installation.

3.2 GENERAL

- A. All CIC-installed cabling shall be installed through the ceiling and use J-hangers, J-hooks, or other equivalent supports to route cable where conduits, ducts or trays are not available. These supports shall be installed at least every three-to-four feet (3-4’).
- B. All CIC-installed cabling not installed in conduit shall be self-supported (i.e., not sharing a support structure with the ceiling grid or other suspended components), and installed such that a visible sag is present between supports.

- C. It is the responsibility of the CIC to review any associated conduit plans and notify Sentinel, the General Contractor, the EC, and the architect of any concerns, deficiencies, changes, or areas of cost savings regarding conduit size, placement, routing, and location, sizing, and quantity of pull boxes.
- D. All pathways shall be installed such that the recommended respective bend radii of the cables are not exceeded.
- E. All CIC-installed horizontal station cables shall not exceed 90 meters in length from their termination point at the station outlet and the termination point at the cross-connect.
- F. All UTP and coaxial cables shall be installed at a minimum distance of six inches (6") from the nearest sources of electromagnetic interference including such sources as radio antennas, radar transmitters, X-ray equipment, medium and high voltage electrical wiring, induction heaters, fluorescent fixtures, ballasts and high-intensity discharge devices.
- G. All CIC-installed cables shall be installed at a minimum distance of twenty four inches (24") from steam or hot water piping.
- H. All UTP cables shall not be installed parallel to, nor at the same level as the lighting fixtures.

END OF SECTION

SECTION 271500 – TELECOMMUNICATIONS ROOM REQUIREMENTS

PART 1 - GENERAL

1.1 RELATED DOCUMENTS

- A. Drawings (“associated project drawings”) and general provisions of the Contract, including General and Supplementary Conditions and other Division 01 Specification Sections, apply to this Section.

1.2 SUMMARY

- A. This section includes:
 - 1. Cabinets/Open Relay Racks
 - 2. Ladder tray

1.3 SCOPE

- A. The CIC shall provide all materials, tools, equipment and labor required for the complete installation of the Work called for in the contract documents provided by the architect or Sentinel related to the telecommunications rooms’ cabling system.

1.4 SUBMITTALS

- A. Refer to Section 271000, Part 1, Section 1.6, for all submittal requirements.

1.5 COORDINATION

- A. The CIC shall review any and all pathways to identify areas or locations where there may be conflict with other trades, particularly architectural, mechanical, electrical, plumbing, or fire protection-related.
- B. The CIC shall coordinate all installation with the architects, MEP engineers and the other trades on the project.

PART 2 - PRODUCTS

2.1 CABINETS/OPEN RELAY RACKS

- A. Refer to the associated drawings for the specified part numbers and layouts.
- B. These cabinets/racks shall also be grounded to the telecommunications grounding busbar (busbar by others).
- C. The CIC shall furnish and install a grounding strip within each cabinet/relay rack in order to facilitate the correct grounding of the relay rack.

2.2 LADDER TRAY

- A. The CIC shall install a twelve inch (12”) wide ladder type cable tray with a black finish within the telecommunications room to allow for the installation of cabling to the rack-mounted patch panels, as well as to provide the owner with the means to patch between the cabinets/racks (refer to associated drawings for exact placement).
- B. The CIC shall further furnish and install all necessary brackets, mounts, supports, and clamps to provide a complete tray system in compliance with manufacturer requirements.

PART 3 - EXECUTION

3.1 OPEN RELAY RACKS

- A. The two post open relay racks shall be level and be securely bolted to the floor. The CIC shall install a minimum #6 AWG ground wire from each cabinet/open relay rack to the nearest telecommunications grounding busbar.
- B. After installation, protect the components from damage during construction. If damage occurs despite such protections, remove and replace all damaged components or the entire unit as required to provide components in original, undamaged condition.

3.2 LADDER TRAY

- A. The CIC shall mount the ladder tray system to the height or heights indicated on the drawings. Finished horizontal segments shall be level within one-eighth inch.
- B. The CIC shall observe all bend radius requirements as allowed by the field conditions, and in accordance with Sentinel drawings or directions. The CIC shall assume a 10x radius for the largest fiber sheath (if present) or a 4x or four inch (4") radius (whichever is greater) for copper conductors. The CIC shall notify Sentinel if bend radius requirements exceed the width of the ladder tray defined herein.
- C. All vertical bends shall follow bend radius requirements as allowed by the field conditions as described in B, above.
- D. The entire tray system shall be grounded to the nearest telecommunications busbar as described in Section 271600.
- E. The CIC shall review the associated drawings and observe any components intended to be mounted to the ladder tray (backboxes, panels, standoff brackets, etc.); the CIC shall ensure that no supports, brackets, or hardware could interfere with the placement or function of these critical design components.
- F. The CIC shall verify that the combined weight of the cabling does not exceed the weight capacity of any segment of the tray system prior to installation; in the event that the combined weight of cabling exceeds the loading of the proposed tray system, the CIC shall contact the architect as well as Sentinel for direction.
- G. After installation, protect the components from damage during construction. If damage occurs despite such protections, remove and replace all damaged components or the entire unit as required to provide components in original, undamaged condition.

END OF SECTION

SECTION 271600 – TELECOMMUNICATIONS GROUNDING REQUIREMENTS

PART 1 - GENERAL

1.1 RELATED DOCUMENTS

- A. Drawings (“associated project drawings”) and general provisions of the Contract, including General and Supplementary Conditions and other Division 01 Specification Sections, apply to this Section.

1.2 SUMMARY

- A. This section includes:
 - 1. Grounding system
 - 2. Telecommunications main grounding busbar
 - 3. Bonding conductors
 - 4. Telecommunications bonding backbone
 - 5. Grounding equalizers
 - 6. Telecommunications grounding busbars
 - 7. Bonding jumpers
 - 8. Grounding telecommunications equipment

1.3 SCOPE

- A. The CIC shall provide all materials, tools, equipment and labor required for the complete installation of the Work called for in the contract documents provided by the architect or Sentinel related to the telecommunications grounding system.

1.4 SUBMITTALS

- A. Refer to Section 271000, Part 1, Section 1.6, for all submittal requirements.

1.5 COORDINATION

- A. The CIC shall coordinate all ground-related work with the EC and GC to determine installation responsibility.

PART 2 - PRODUCTS

2.1 GROUNDING SYSTEM

- A. The CIC shall furnish and install all required grounding components for racks, cable trays, sleeves, and conduits to allow interconnection with the telecommunications grounding system.
- B. Some materials and components may already exist or may be provided and installed by the electrical contractors (EC). The CIC and GC shall verify the responsibilities accordingly from the following information. Refer to the associated project drawings for quantities and locations of the following components.

2.2 TELECOMMUNICATIONS MAIN GROUNDING BUSBAR

- A. Telecommunications Main Grounding Busbar (TMGB). The TMGB serves as a dedicated extension of the building grounding electrode system and serves as the central attachment point for the TBB(s) and components.

- B. The TMGB shall be predrilled with holes for use with standard sized lugs and have minimum dimensions of 0.25-inches thick by 4-inches wide and a minimum of 24-inches long.
- C. The grounding busbar shall be furnished and installed by the EC.

2.3 BONDING CONDUCTOR FOR TELECOMMUNICATIONS

- A. Bonding Conductor for Telecommunications (BCT). The BCT bonds the TMGB to the electrical power ground.
- B. The minimum size conductor used shall be a 6 AWG.

2.4 TELECOMMUNICATIONS BONDING BACKBONE

- A. Telecommunications Bonding Backbone (TBB). The TBB is a 6 AWG or larger bonding conductor that provides a direct bond between different telecommunication grounding locations within the building.
- B. The TBB shall connect all TGBs to the TMGB, and shall be sized at 2 kcmil per linear foot of conductor length up to a maximum of 4/0 AWG.
 - 1. If the TBB is less than 13-feet long, utilize a 6 AWG conductor.
 - 2. If the TBB is 13 – 19.99-feet long, utilize a 4 AWG conductor.
 - 3. If the TBB is 20 – 25.99-feet long, utilize a 3 AWG conductor.
 - 4. If the TBB is 26 – 32.99-feet long, utilize a 2 AWG conductor.
 - 5. If the TBB is 33 – 43.99-feet long, utilize a 1 AWG conductor.
 - 6. If the TBB is 44 – 51.99-feet long, utilize a 1/0 AWG conductor.
 - 7. If the TBB is 52 – 65.99-feet long, utilize a 2/0 AWG conductor.
 - 8. If the TBB is 66 – 99.99 long, utilize a 3/0 AWG conductor.
 - 9. If the TBB is 100-feet or longer, utilize a 4/0 AWG conductor.
- C. The TBB will be furnished and installed by the EC.

2.5 GROUNDING EQUALIZER

- A. Grounding Equalizer (GE). In the event two (2) or more TBBs are used within a multistory building, the TBBs shall be bonded together with a GE (Grounding Equalizer) at the top floor and at every third floor in between as required.
- B. The GE should be sized the same as the TBB per the list above.

2.6 TELECOMMUNICATIONS GROUNDING BUSBAR

- A. Telecommunications Grounding Busbar (TGB). The TGB is the grounding connection point for all communications systems and equipment in the area served by the technology space in which it is placed.
- B. The TGB shall be predrilled with holes for use with standard sized lugs and have minimum dimensions of 0.25-inches thick by 2-inches wide and a minimum of 12-inches long.
- C. The grounding busbar shall be furnished and installed by the EC.

2.7 BONDING CONDUCTOR

- A. Bonding Conductor (BC). BCs are used to tie the cable or basket tray, ladder racking, racks, cabinets, conduits and other equipment to the nearest TGB.

- B. NEC 800.40(A) requires at least a 14 AWG stranded-insulated or solid-insulated conductor for connecting telecommunications protectors and associated non-metallic cable sheaths to selected ground.
- C. Ground requirements indicate a minimum 6 AWG stranded conductor with an overall green insulated jacket.
- D. The type of bond used should be sized for the application and the fault current-carrying capacity needed.
- E. The electrical engineers may ask the CIC to install a BC with an unshielded copper backbone cable as a form of protection. This BC shall also be a minimum of 6 AWG and would run parallel with the unshielded backbone cable. The CIC would bond each end to the nearest TGB.

2.8 BONDING JUMPERS

- A. Bonding jumpers shall be furnished and installed as required for all basket tray or ladder tray segments, so that the tray system forms a continuous path to ground.
- B. These jumpers shall be attached by split bolts to the tray system; remove paint from the tray as necessary to ensure metal-to-metal contact.

2.9 HANGER BRACKETS

- A. Utilize ground conductor hanger brackets to feed BCs to the TMGB or TGB within the space.

2.10 GROUNDING EQUIPMENT

- A. All CIC-supplied relay racks shall feature a rack ground busbar mounted to the rear mounting rails one rack unit from the top rail position on each rack, so that equipment mounted in this rack may, on day one or in future, be grounded directly to the telecommunications grounding system. Refer to associated project drawings for additional details.
- B. Other components include but are not limited to the wiring, two-hole compression connectors, copper compression HTAPs, U-bolt grounding clamps, long barrel lugs, jumper kits, etc., to connect all CIC-supplied components within the room in order to provide a complete grounding solution in compliance with the standards listed previously.
- C. Use #12-24 slotted hex-head zinc-plated thread-forming screws in conjunction with paint-piercing washers against all painted surfaces.

PART 3 - EXECUTION

3.1 GROUNDING REQUIREMENTS

- A. Install all grounding components in compliance with the respective components' manufacturer requirements to ensure a continuous grounding system.
- B. The CIC shall install solid conductors for conductors #10 AWG or smaller, and stranded conductors for #6 AWG and larger, unless otherwise indicated.
- C. Use irreversible crimp and/or exothermic welds to form permanent grounding connections. Equipment which may be removed in the future shall use the #12-24 slotted hex-head zinc-plated thread-forming screws in conjunction with paint-piercing washers against all painted surfaces. The CIC shall remove paint as required to ensure a metal-to-metal contact.
- D. Exothermic welded connectors shall be used for all outdoor locations or in locations exposed however briefly to the elements; however, the CIC shall use a bolted clamp for disconnect-type connections.

- E. All conductors shall be routed along the straightest and shortest paths available, unless otherwise indicated or required by Code. Avoid obstructing access or placing conductors where they may be subjected to strain, impact, or damage.
- F. All jumpers, straps, and other bonding components shall be installed in locations permitting inspection and maintenance, except where routed through conduit.
- G. Adjacent racks or cabinets shall be grounded with a home-run connection to the TMGB or TGB (for four racks or cabinets or less), or tapped in series to a grounding connector. Under no circumstances shall racks or cabinets be daisy-chained via grounding conductors, even where permitted by code. Racks or cabinets over raised access flooring may be connected to the sub-floor grounding mesh via an access floor grounding clamp, in lieu of a dedicated home run or tapped into a bus.
- H. Install grounding systems and components so that vibration is not transmitted to rigidly mounted equipment.
- I. The grounding and bonding systems shall be tested using a clamp-on ground-resistant tester and/or using a digital ground-resistant tester. The total grounding system resistance shall be less than 5 ohms. The test results should be kept in an Excel Spreadsheet and submitted to the GC with all the other documents at the end of the project.

END OF SECTION

SECTION 271700 – TESTING, IDENTIFICATION, AND ADMINISTRATION REQUIREMENTS

PART 1 - GENERAL

1.1 RELATED DOCUMENTS

- A. Drawings (“associated project drawings”) and general provisions of the Contract, including General and Supplementary Conditions and other Division 01 Specification Sections, apply to this Section.

1.2 SUMMARY

- A. This section includes:
 - 1. Cable system testing
 - 2. Cabling identification and labeling
 - 3. Cable system administration

1.3 SCOPE

- A. The CIC shall provide all materials, tools, equipment and labor required for the complete installation of the Work called for in the contract documents provided by the architect or Sentinel related to the specifications and requirements for the testing, identification and administration of the communications cabling system.

1.4 SUBMITTALS

- A. Refer to Section 271000, Part 1, Section 1.6, for all submittal requirements.

PART 2 - PRODUCTS

2.1 COMMUNICATIONS CABLING SYSTEM TESTING

- A. UTP Cabling
 - 1. A Level IIIe-certified testing device shall be used. The tester shall have been field calibrated within the last month.
 - 2. The CIC shall ensure that the appropriate adapters and test cords are used.
 - 3. All pairs of horizontal station and backbone cabling shall be tested from the jack to the patch panel or block, and from patch panel to patch panel in a bi-directional manner.
 - 4. All testing shall be conducted on the permanent link.
 - 5. All testing shall be in conformance with the manufacturer's requirements to obtain application performance warranty certification.
- B. Fiber Optic Cabling Optical Loss Testing
 - 1. Multimode links shall be tested in on direction at 850nm and 1300nm in accordance with ANSI/TIA-526-14-C, one-cord reference method, with an encircled flux compliant launch.
 - 2. Link attenuation does not include any active or passive devices other than cable, connectors, and splices.
- C. OTDR Fiber Testing
 - 1. Fiber links shall be tested at these wavelengths for anomalies and to ensure uniformity of cable attenuation, connector insertion loss and reflectance.
 - 2. Multimode: 850nm and 1300nm

3. Each fiber link and channel shall be tested in both directions.
 - a. The launch and tail fibers shall remain in place for the measurement in the opposite direction
 - b. The use of a loop back fiber at the far end with a tail fiber at the near end on the adjacent fiber is permitted for bi-directional testing so long as the OTDR is able to split the trace automatically into two traces for the two fibers under test.
4. A launch cable shall be installed between the OTDR and the first link connection.
5. A tail cable shall be installed after the last link connection.
- D. Magnified Fiber End Face Inspection
 1. Fibers shall be inspected using a video scope. The following test limits shall be used:
 - a. Multimode connectors; table 6 of IEC 61300-3-35 edition 1.0
- E. Fiber Length Measurement
 1. The length of each fiber shall be recorded.
 2. The length shall be measured using an OTDR.
- F. Fiber Polarity Testing
 1. Paired duplex fibers in multi-fiber cables shall be tested to verify polarity in accordance with clause E.5.3 of ANSI/TIA-568.3-D. The polarity of the paired duplex fibers shall be verified using an OLTS.

2.2 COMMUNICATIONS CABLING SYSTEM IDENTIFICATION

- A. Labels shall meet the legibility, exposure defacement and adhesion requirements of UL969.
- B. Labels shall be preprinted or printed by a computer. Labels written by hand are not acceptable.

2.3 COMMUNICATIONS CABLING SYSTEM ADMINISTRATION

- A. The CIC shall provide record drawings in an AutoCAD compatible format or in PDF format.

PART 3 - EXECUTION

3.1 COMMUNICATIONS CABLING SYSTEM TESTING

- A. All pairs of all horizontal station cabling and backbone cabling shall be tested from the jack to the patch panel or block, and from patch panel to patch panel in a bi-directional manner using a Level IV certified testing device.
- B. All testing shall be conducted on the permanent link.
- C. The CIC shall provide test results and certification as to the communications cabling system's adherence to the standards and performance requirements referenced in this document.
- D. Test results shall meet or exceed the requirements set forth in the respective sections of this document.

3.2 COMMUNICATIONS CABLING SYSTEM IDENTIFICATION

- A. The CIC shall thoroughly label the entire communications cabling system for future maintainability.
- B. All station cables shall be labeled at the faceplate, the patch panel jack or port, and the rear of the patch panel above (for UTP) or jack or port position (fiber or coax) indicating location number.

- C. All backbone cables shall be labeled at the patch panel jack or port, and the rear of the patch panel above or port position (fiber or coax) indicating location number.

3.3 COMMUNICATIONS CABLING SYSTEM ADMINISTRATION

- A. The CIC shall thoroughly document the entire communications cabling system for future maintainability and troubleshooting.
- B. Documentation shall include but not be limited to:
 - 1. AutoCAD or PDF scale drawings of the project (backgrounds available from Sentinel) clearly showing:
 - a. Precise faceplate locations and identification numbers
 - b. Approximate pathways of horizontal cable runs to their nearest points of termination
 - c. Approximate pathways of all backbone cable runs to their respective points of termination
 - d. Precise locations of installed pull boxes, junction boxes, and enclosures related to any communications conduits that may be installed
 - e. Conduit sizes for any conduit above three quarter inch (3/4") in size (if used)
 - f. Detailed elevation views of any wall-mounted equipment, including but not limited to 110 blocks, wall-mounted patch panels, grounding busbars
 - g. Single line diagrams and/or backbone schematics
 - 2. Product cut sheets, shop drawings, etc., as outlined in 271000, 1.5.
 - 3. Documentation shall be submitted to the owner prior to final payment.

END OF SECTION

SECTION 271800 – CUTOVER AND TRAINING REQUIREMENTS

PART 1 - GENERAL

1.1 RELATED DOCUMENTS

- A. Drawings (“associated project drawings”) and general provisions of the Contract, including General and Supplementary Conditions and other Division 01 Specification Sections, apply to this Section.

1.2 SUMMARY

- A. This section includes:
 - 1. Cutover services
 - 2. Training services

1.3 SCOPE

- A. The CIC shall provide all materials, tools, equipment and labor required for the complete installation of the Work called for in the contract documents provided by the architect or Sentinel related to the specifications and requirements for the cutover of the communications cable system and subsequent user training.

1.4 SUBMITTALS

- A. Refer to Section 271000, Part 1, Section 1.6, for all submittal requirements.

1.5 COORDINATION

- A. The CIC shall coordinate all training with the owner to determine the extent, duration, and schedule of the training session.

PART 2 - PRODUCTS

2.1 CUTOVER AND TRAINING SERVICES

- A. The CIC shall provide on-site support during and immediately after start-up for a period of 2 business days.
- B. The CIC shall provide training for the owner’s personnel to ensure knowledge transfer regarding documentation and operation of the communications cabling system.

PART 3 - EXECUTION

3.1 CUTOVER AND TRAINING SERVICES

- A. The CIC shall be available or on-call with a 2-hour response time for 2 business days after the communications cabling system is turned over to the owner in order to investigate and repair any components of the system that do not function properly.
- B. The CIC shall provide a training session with the appropriate owner staff to explain and orient the staff in the use and maintenance of the communications cabling system. This training session shall be scheduled directly with the owner prior to turnover.
- C. The CIC is not responsible for the mounting of active components or configuration of active components.
- D. At closeout, clean or re-clean entire work to normal level for "first class" maintenance/cleaning of building projects of a similar nature. Remove non-permanent protection and labels, clean exposed

finishes, touch-up minor finish damage, remove debris and broom-clean spaces, sanitize work, and perform similar cleanup operations needed to produce a clean condition

END OF SECTION

SECTION 271900 – SUPPORT AND WARRANTY REQUIREMENTS

PART 1 - GENERAL

1.1 RELATED DOCUMENTS

- A. Drawings (“associated project drawings”) and general provisions of the Contract, including General and Supplementary Conditions and other Division 01 Specification Sections, apply to this Section.

1.2 SUMMARY

- A. This section includes the support and warranty of the communications cable system.

1.3 SCOPE

- A. The CIC shall provide all materials, tools, equipment and labor required for the complete installation of the Work called for in the contract documents provided by the architect or Sentinel related to the specifications and requirements for the support and warranty of the communications cabling system.

1.4 SUBMITTALS

- A. Refer to Section 271000, Part 1, Section 1.6, for all submittal requirements.

PART 2 - PRODUCTS

2.1 SUPPORT AND WARRANTY

- A. The communications cabling system shall be end-to-end certified by the CIC and the manufacturer.
- B. An extended material, labor and performance warranty shall be provided by the manufacturer.
- C. A written document addressing the communication cabling system’s certification shall be provided by the manufacturer at the completion of the project.

PART 3 - EXECUTION

3.1 SUPPORT AND WARRANTY

- A. Once the communications cabling system is certified, the CIC shall repair—at no additional charge—any part of the communications cabling system that is not working properly within 24 hours of the report of the problem, unless other arrangements are made with the manufacturer issuing the warranty.
- B. The CIC shall deliver to the owner documentation outlining the terms and conditions of the warranty. A minimum 20-year application performance warranty is required.

END OF SECTION

Henry Puffer Elementary School - D58 Referendum Improvements

Downers Grove School District 58

2220 Hadow Ave

Downers Grove, IL 60515

220281

December 18, 2023

ISSUED FOR E-RATE RFP

NOT FOR CONSTRUCTION

PROJECT TEAM		DRAWING SHEET INDEX		LOCATION
<p>CLIENT DOWNERS GROVE GRADE SCHOOL DISTRICT 58 2300 WARRENVILLE RD, SUITE 200 NE DOWNERS GROVE, IL 60516 PHONE: (630)719-5858 CONTACT: KEVIN BARTO</p> <p>STRUCTURAL ENGINEER WIGHT & COMPANY 2500 NORTH FRONTAGE ROAD DARIEN IL, 60561 PHONE: (630)969-7000 FAX: (630)969-7979 CONTACT: MATT AQUINO Design Firm Registration #184-000451</p> <p>TECHNOLOGY SERVICES SENTINEL TECHNOLOGIES 2550 WARRENVILLE RD. DOWNERS GROVE, IL 60515 PHONE: (630) 769-4284 CONTACT: FRANK KRISTOFF</p> <p>ELECTRICAL ENGINEER WIGHT & COMPANY 2500 NORTH FRONTAGE ROAD DARIEN IL, 60561 PHONE: (630)969-7000 FAX: (630)969-7979 CONTACT: ANTHONY SULLENTRUP Design Firm Registration #184-000451</p>	<p>ARCHITECT WIGHT & COMPANY 2500 NORTH FRONTAGE ROAD DARIEN IL, 60561 PHONE: (630)969-7000 FAX: (630)969-7979 CONTACT: AMY TIBERI Design Firm Registration #184-000451</p> <p>PLUMBING & FIRE PROTECTION ENGINEER WIGHT & COMPANY 2500 NORTH FRONTAGE ROAD DARIEN IL, 60561 PHONE: (630)969-7000 FAX: (630)969-7979 CONTACT: BILL BAUER Design Firm Registration #184-000451</p> <p>MECHANICAL ENGINEER WIGHT & COMPANY 2500 NORTH FRONTAGE ROAD DARIEN IL, 60561 PHONE: (630)969-7000 FAX: (630)969-7979 CONTACT: SUDESH SARAF Design Firm Registration #184-000451</p>	<p>BUILDING CODE DATA</p> <p>1. APPLICABLE CODES BUILDING CODE: 2015 INTERNATIONAL EXISTING BUILDING CODE MECHANICAL CODE: 2015 INTERNATIONAL MECHANICAL CODE ELECTRICAL CODE: 2014 NATIONAL ELECTRICAL CODE PLUMBING CODE: ILLINOIS PLUMBING CODE - CURRENT EDITION ACCESSIBILITY CODE: 2018 ILLINOIS ACCESSIBILITY CODE ENERGY CODE: 2018 INTERNATIONAL ENERGY CONSERVATION FIRE CODE: 2015 INTERNATIONAL FIRE CODE OTHER CODES: 2015 IBC FUEL GAS CODE</p> <p>2. GENERAL BUILDING DESCRIPTION GROSS BUILDING AREA, EXISTING: 54,934 SF GROSS BUILDING AREA, TOTAL (NEW & EXISTING): 54,934 SF</p> <p>3. BUILDING OCCUPANCY TYPE OCCUPANCY CLASSIFICATION: E SECTION 302</p> <p>4. CONSTRUCTION TYPE CONSTRUCTION TYPE: IV SECTION 503, 602 FIRE RESISTANCE RATING REQUIREMENTS: TABLE 601 STRUCTURAL FRAME: 0 HR BEARING WALLS (EXTERIOR) (ALSO SEE TABLE 602): 2 HR BEARING WALLS (INTERIOR): 1 HR NON-BEARING WALLS (EXTERIOR): SEE TABLE 602 NON-BEARING WALLS (INTERIOR): SEE TABLE 602.4.6 FLOOR CONSTRUCTION: HT ROOF CONSTRUCTION: HT EXTERIOR WALL FIRE SEPARATION DISTANCE: TABLE 602 LESS THAN 5': 1 HR LESS THAN OR EQUAL TO 5' TO LESS THAN 10': 1 HR LESS THAN OR EQUAL TO 10' TO LESS THAN 30': 1 HR GREATER THAN OR EQUAL TO 30': 0 HR</p> <p>ADDITIONAL CODE IEBC CHAPTER 4 PRESCRIPTIVE COMPLIANCE PATH DICTATE WHERE FIRE RATING WILL BE REQUIRED COMMON PATH OF EGRESS - 75 FEET MAX. MAX TRAVEL DISTANCE - 200 FEET</p>	<p>GENERAL G0.00 G0.02</p> <p>TECHNOLOGY T0.0 T1.0 T1.1 T1.2 T1.3 T1.4</p> <p>COVER SHEET GENERAL INFORMATION, SYMBOLS, NOTES & ABBREVIATIONS</p> <p>LEGEND AND GENERAL NOTES TECHNOLOGY PLAN - LOWER LEVEL AREA A TECHNOLOGY PLAN - FIRST FLOOR AREA A TECHNOLOGY PLAN - FIRST FLOOR AREA B TECHNOLOGY PLAN - FIRST FLOOR AREA C TECHNOLOGY PLAN - FIRST FLOOR AREA D</p>	

ILLINOIS ENERGY CONSERVATION CODE STATEMENT OF COMPLIANCE

I HAVE PREPARED OR CAUSED TO BE PREPARED UNDER MY DIRECT SUPERVISION, THE ATTACHED PLANS AND SPECIFICATIONS AND STATE THAT, TO THE BEST OF MY KNOWLEDGE AND BELIEF AND TO THE EXTENT OF MY CONTRACTUAL OBLIGATION, THEY ARE IN COMPLIANCE WITH THE REQUIREMENTS OF THE 2015 ILLINOIS ENERGY CONSERVATION CODE

SIGNED: _____

ILLINOIS REGISTRATION NO.: _____

DATE: _____

ARCHITECT

SEAL & SIGNATURE APPLY TO GENERAL AND ARCHITECTURAL SHEETS INDICATED ON G0.01 SHEET AS G, A-SERIES, AND INCLUDED IN THE PERMIT DOCUMENTS.

SIGNED: _____

ILLINOIS REGISTRATION NO.: _____

DATE: _____

STATEMENT OF COMPLIANCE

I HAVE PREPARED OR CAUSED TO BE PREPARED UNDER MY DIRECT SUPERVISION, THE ATTACHED PLANS AND SPECIFICATIONS AND STATE THAT, TO THE BEST OF MY KNOWLEDGE AND BELIEF AND TO THE EXTENT OF MY CONTRACTUAL OBLIGATION, THEY ARE IN COMPLIANCE WITH THE ENVIRONMENTAL BARRIERS ACT (IL. REV. STAT. 1985, CH. 111 1/2, PARS. 3711 ET SEQ AS AMENDED) AND THE ILLINOIS ACCESSIBILITY CODE, 71 IL ADM. CODE 400.

SIGNED: _____

ARCHITECT/ENGINEER

ILLINOIS REGISTRATION NO.: _____

DATE: _____

FOR UNDERGROUND UTILITY LOCATIONS, CALL J.U.L.I.E.

TOLL FREE TEL. 1-800-892-0123
JULIE SUBURBS & DIGG CHICAGO

- YELLOW _____ GAS
- RED _____ ELECTRICAL
- ORANGE _____ PHONE / TV COMMUNICATION
- BLUE _____ WATER
- GREEN _____ SEWERS
- WHITE _____ SAFE TO DIG

TYPICAL FIXTURE MOUNTING HEIGHTS, U.N.O.

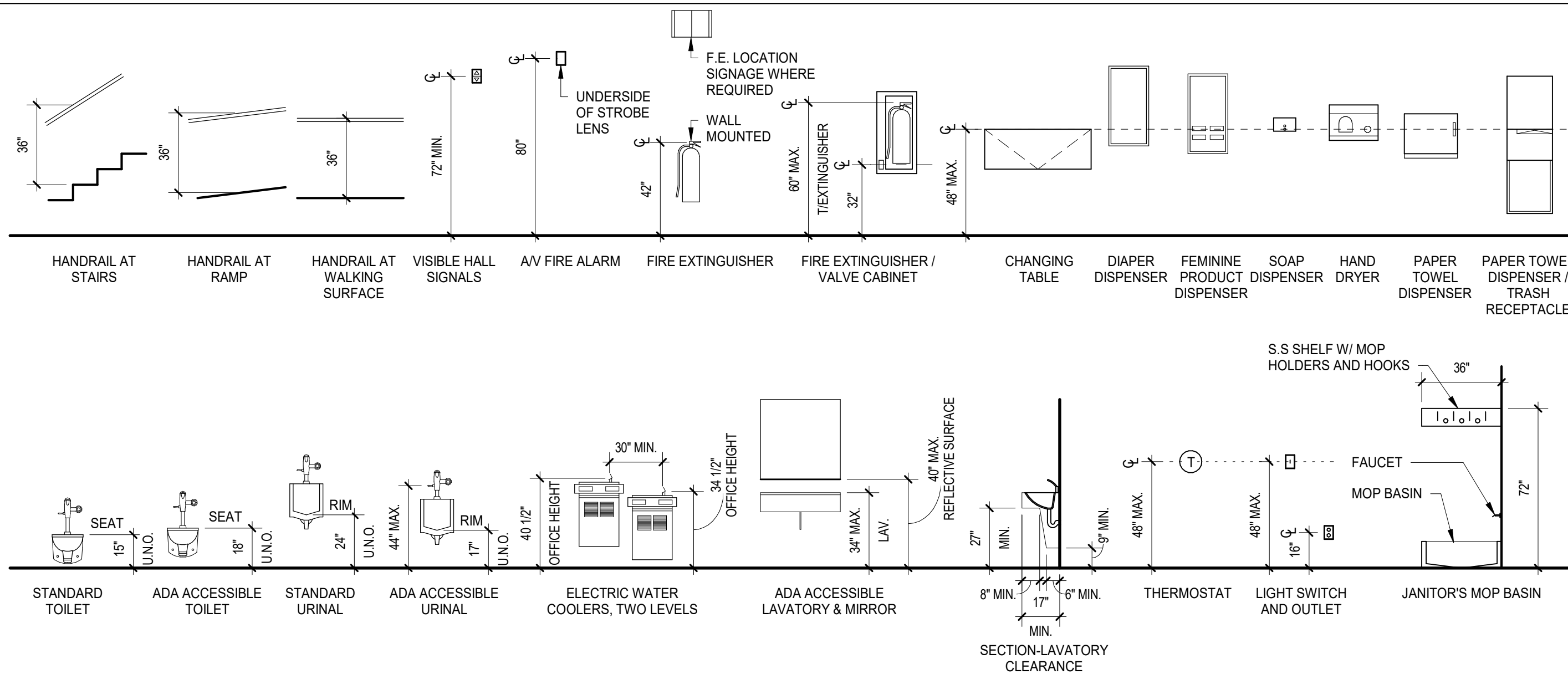

FIRESTOP SYSTEM MATRIX

NOTES:
 1. UL TEST DESIGNATION SHOWN ARE FOR GUIDANCE ONLY. CONTRACTOR SHALL PROVIDE SUBMITTALS FOR EACH BASED ON ACTUAL FIELD CONDITIONS.
 2. REFER TO THE UL THROUGH PENETRATION GUIDELINES FOR ADDITIONAL USE OF SYSTEMS.
 3. CONTRACTOR SHALL COORDINATE THE ALLOWED MOVEMENT OF A FIRESTOP SYSTEM WITH THE STRUCTURAL ENGINEERS ANTICIPATED SLAB MOVEMENT.
 4. IF ANY DEVIATIONS OCCUR FROM THE SYSTEMS SHOWN, THE CONTRACTOR SHALL SUBMIT AN ALTERNATE UL TESTED SYSTEM OR MANUFACTURER'S ENGINEERING JUDGMENT.
 5. ALL EXISTING CORRIDOR WALLS ARE 1 HOUR RATED. PROVIDE FIRE STOPPING AS APPLICABLE.

THROUGH-PENETRATIONS

DESCRIPTION	CONCRETE FLOOR OR BLOCK WALLS	GYPSON WALLS	GYPSON SHAFT WALLS
BLANK OPENING	CAJ-0090 FA-0014	WL-0012 WL-0040	
METAL PIPE	CAJ-1226 FA-1016	WL-1054 WL-1297	WL-1205 WL-1380
PLASTIC PIPE	CAJ-2109 FA-2054	WL-2078 WL-2128	
INSULATED PLASTIC PIPE	CAJ-5320	WL-5225	
CABLE BUNDLE	CAJ-3095 FA-3007	WL-3065 WL-3334 WL-3384	WL-3161
CABLE TRAYS	CAJ-4071 CAJ-4083	WL-4011	
METAL PIPE WITH GLASS FIBER OR POLYISO INSUL.	FA-5032 CAJ-5091 FA-5017	WL-5029 WL-5257	WL-5244
METAL PIPE WITH AB/PVC INSUL.	CAJ-5090 FA-5032 FA-5015	WL-5028 WL-5143	
MISC. ELECTRICAL/ BUSWAY	CAJ-6017 CAJ-6042	WL-6019	
SHEET METAL DUCT/ RECTANGULAR	CAJ-7051	WL-7040 WL-7155 WL-7059	
SHEET METAL DUCT/ ROUND	CAJ-7084	WL-7042 WL-7153	WL-7068
MULTIPLE PENETRATIONS	CAJ-8143 FA-8012 FA-5032	WL-8065 WL-8079 WL-8071	WL-8098

TOP OF WALL JOINTS

DESCRIPTION	CONCRETE BLOCK WALLS	GYPSON WALLS	EXTERIOR WALL
PERP. TO METAL DECK	HWD-0042 HWD-1066/1067 HWD-0045	HWD-1037 HWD-0081	
PARALLEL TO METAL DECK	HWD-0049 HWD-1067 HWD-0184 HWD-0539	HWD-0181 HWD-0081	
PARALLEL TO STEEL BEAM	HWD-0259		
FLAT CONCRETE	HWD-1068 HWD-0208	HWD-1058 HWD-0268	
CUT TO PROFILE	HW-0324		
SHAFT WALL PARALLEL TO DECK	HWD-0570		
SHAFT WALL PERP. TO DECK	HWD-0569		
SHAFT WALL TO FLAT CONCRETE	HWD-0342 HWD-0572		

ABBREVIATIONS

ACCESS. ACI.	ACCESSIBLE AMERICAN CONCRETE INSTITUTE	MAS. MFR./MANUF. MDF	MASONRY MANUFACTURER
ACOUST. ACT ADA	ACOUSTICAL AMERICANS WITH DISABILITIES ACT	MIL. MIN.	MEDIUM DENSITY FIBERBOARD MILLIMETERS
A.F.F. ALT.	ABOVE FINISHED FLOOR ALTERNATE	MISC. MHO	MISCELLANEOUS MAGNETIC HOLD OPEN
ALUM./AL. APPROX.	ALUMINUM APPROXIMATE	M.O. MTL.	MASONRY OPENING METAL
ARCH. ASTM.	ARCHITECTURAL AMERICAN SOCIETY FOR TESTING AND MATERIALS	NEG. N.I.C.	NOT IN CONTRACT NUMBER
@	AT	NTS	NOT TO SCALE
AV	AUDIO VISUAL	OC.	ON CENTER
BD.	BOARD	OD.	OUTSIDE DIAMETER
BLDG.	BUILDING	ORD.	OVERFLOW ROOF DRAIN
BM	BEAM	P.B.	PIPE BOLLARD
B/O	BOTTOM OF	PERS.	PERSON
BRK.	BREAK	PL./P. LAM.	PLATE
CAB	CABINET	PLY	PLYWOOD
CC	CENTER TO CENTER	PP.	DOOR ACTUATOR PUSH PLATE
C	CENTERLINE	R	RADIUS
CJ	CONTROL JOINT	PSF.	POUNDS PER SQUARE FEET
CMU	CONCRETE MASONRY UNITS	PSI	POUNDS PER SQUARE INCH
COL.	COLUMN	PT/PTD	PAINTED
CLG.	CEILING	P.T.	PRESSURE TREATED
CLR.	CLEAR	RAD.	RADIUS
CONC.	CONCRETE	RCP	REFLECTED CEILING PLAN
CONT.	CONTINUOUS	RD	ROOF DRAIN
CONTR.	CONTRACTOR	RESTRM.	RESTROOM
CORR.	CORRIDOR	RM.	ROOM
CPT.	CARPET	R.O.	ROUGH OPENING
CR.	ACCESS CARD READER	RTU.	ROOF TOP UNIT
CT.	CERAMIC TILE	SAFB	SOUND ATTENUATION FIBER BATT INSULATION
DEMO	DEMOLITION	SC.	SEALED CONCRETE
DIA.	DIAMETER	SCHD./SC	SCHEDULE
DIMS.	DIMENSIONS	SH.	SHEET
DN.	DOWN	SIM.	SIMILAR
DR.	DOOR	SJ.	STEEL JOINT INSTITUTE
DS.	DOWN SPOUT	S.M.	SHEET METAL
DWG.S.	DRAWINGS	SPA.	SPACES
EA.	EACH	SPEC.	SPECIFICATIONS
EIFS	EXTERIOR INSULATED FINISH SYSTEM	ST.	STONE TILE
EL.	ELEVATION	STC	SOUND TRANSMISSION COEFFICIENT
ELEC.	ELECTRICAL	STB.	STONE TILE BASE
ELEV.	ELEVATOR	STL	STEEL
E.J.	EXPANSION JOINT	ST. ANGLE	STEEL ANGLE
EQ.	EQUAL	STL/SS	STAINLESS STEEL
EQUIP.	EQUIPMENT	STOR.	STORAGE
EWC	ELECTRIC WATER COOLER	STRUCT.	STRUCTURAL
EXP	EXPANSION	SV	SHEET VINYL
EXT	EXTERIOR	SYN	SYNTHETIC
EXIST.	EXISTING	T/	TOP OF
ETR	EXISTING TO REMAIN	T/FTG.	TOP OF FOOTING
FD	FLOOR DRAIN	TNT	TEXTURED PAINT
FEC	FIRE EXTINGUISHER	TYP	TYPICAL
FF	FACTORY FINISH	UNO.	UNLESS NOTED OTHERWISE
FIN.	FINISHED	USGS.	UNITED STATES GEOLOGICAL SURVEY
FL/FLR.	FLOOR	VB	VINYL BASE
FOUND.	FOUNDATION	VCT.	VINYL COMPOSITION TILE
FT.	FOOT/FEET	VERT.	VERTICAL
FTG.	FOOTING	V.I.F.	VERIFY IN FIELD
GA.	GAUGE	VWC.	VINYL WALL COVERING
GALV.	GALVANIZED	WC	WATER CLOSET
GWB/ GYP. BD.	GYPSON WALL BOARD	WD	WOOD
HD	HEAVY DUTY	W	WOMENS
HM	HOLLOW METAL	W/	WITH
HOR.	HORIZONTAL	W/O	WITHOUT
HP	HIGH POINT	WWF.	WELDED WIRE FABRIC
HT/HGT.	HEIGHT		
HVAC	HEATING, VENTILATION & AIR CONDITIONING		
IN	INCH		
INSUL.	INSULATED/INSULATION		
INT	INTERIOR		
JOINT	JOINT		
LAV	LAVATORY		
LINO.	LINOLEUM		
LBS.	POUNDS		
LP	LOW POINT		
LVL.	LEVEL		
M	MENS		
MAT.	MATERIAL		
MAX.	MAXIMUM		

GENERAL NOTES

- WORK, MATERIALS AND METHODS SHALL BE IN CONFORMANCE WITH THE CODES, ORDINANCES AND REGULATIONS OF GOVERNMENTAL AGENCIES HAVING JURISDICTION AT THE PROJECT LOCATION.
- UNLESS OTHERWISE INDICATED IN THE CONSTRUCTION DOCUMENTS AS BEING NOT IN CONTRACT (N.I.C.) OR EXISTING, ITEMS, MATERIALS AND INSTALLATION OF SAME ARE PART OF THE CONTRACT AS DEFINED BY THE CONSTRUCTION DOCUMENTS. THE CONTRACTORS SHALL PROVIDE AND INSTALL ACCESSORIES, COMPONENTS AND ASSEMBLIES REQUIRED FOR THE WORK DEPICTED OR SPECIFIED.
- EACH CONTRACTOR SHALL BE RESPONSIBLE FOR VERIFYING DIMENSIONS AND EXISTING CONDITIONS BEFORE COMMENCING WORK. REPORT DISCREPANCIES AND/OR POTENTIAL PROBLEMS PRIOR TO PROCEEDING WITH AFFECTED WORK.
- FIRE-RATED ASSEMBLIES SHALL BE INSTALLED, LABELED, AND INSPECTED IN ACCORDANCE WITH THE APPLICABLE CODES. THIS INCLUDES FIRE DAMPERS OR FIRE DOORS PROVIDED WHERE AIR DUCTS OR OPENINGS PENETRATE FIRE RATED SURFACES. PENETRATIONS OF RATED FIRE RESISTIVE CONSTRUCTION SHALL BE PROTECTED WITH APPROVED FIRE ASSEMBLIES.
- PENETRATIONS THROUGH SURFACE SHALL BE SEALED WITH SEALANT MATERIAL PER SPECIFICATIONS. FOR PLUMBING, FIRE SPRINKLER AND ELECTRICAL SYSTEMS.
- IN THE EVENT OF DISCREPANCIES BETWEEN DRAWINGS AND/OR SPECIFICATIONS, THE MORE COSTLY OR MORE RESTRICTIVE CONDITIONS SHALL BE DEEMED THE CONTRACT REQUIREMENT UNLESS OTHERWISE STATED IN WRITING.
- PROVIDE GALVANIC PROTECTION BETWEEN DISSIMILAR MATERIALS, WHERE REQUIRED.
- KEEP PIPING AS CLOSE TO WALLS AS POSSIBLE UNLESS NOTED OTHERWISE.
- NO CONTRACTORS SHALL CLOSE OR OBSTRUCT STREETS, DOCKS, ALLEYS OR WALKS. NO MATERIALS ARE TO BE PLACED OR STORED IN STREETS, ALLEYS OR WALKS. DEBRIS IS TO BE REMOVED COMPLETELY FROM THE PREMISES.
- CONTRACTORS SHALL PROVIDE AND ARE SOLELY RESPONSIBLE AND LIABLE FOR PUBLIC AND EMPLOYEE PROTECTION AS NECESSARY AND AS REQUIRED BY THE CODES, INCLUDING EXTERIOR, INTERIOR PEDESTRIAN AND TRAFFIC BARRIERS. EXISTING EXIT CORRIDORS, PATHS OF EXITS, STAIRWAYS, OR EXIT SIGNAGE, MUST HAVE A CLEAR MEANS OF EGRESS DURING PHASES OF CONSTRUCTION.
- CONTRACTORS WISHING TO WORK IN THE BUILDING OR ON THE BUILDING PROPERTY SHALL BE REQUIRED TO PRESENT THE PROPER CERTIFICATES OF INSURANCE. CONTRACTORS ARE REQUIRED TO BE LICENSED WITH THE LOCAL JURISDICTION. LICENSES AND BONDING ARE TO BE INCLUDED IN THE BID PER THE REQUIREMENTS IN THE SPECIFICATIONS.
- DIMENSIONS NOTED ON THE ARCHITECTURAL FLOOR PLAN REGARDING DETAILS AND PARTITION THICKNESSES ARE NOMINAL DIMENSIONS. REFER TO A8 SERIES FOR THE EXACT DIMENSION.

GRAPHIC SYMBOLS

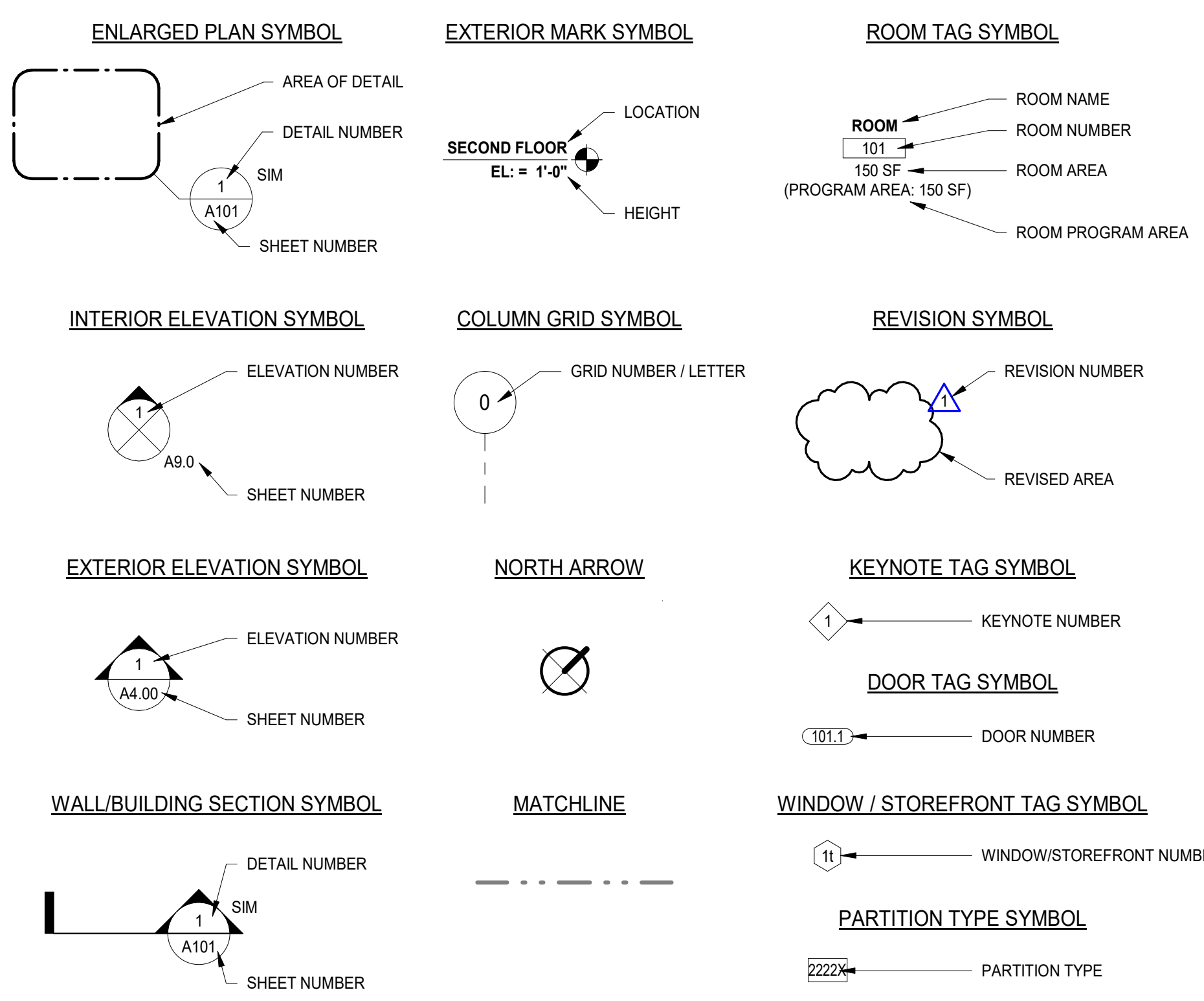

MATERIAL LEGEND

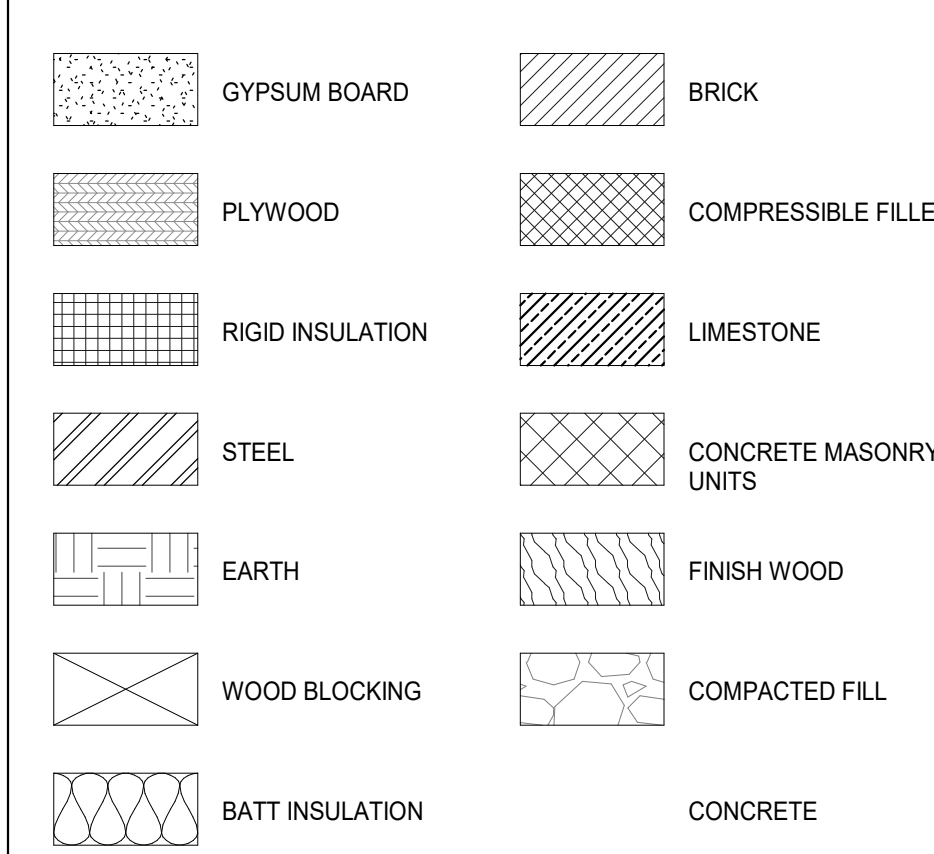

FURNISHED AND INSTALLED MATRIX.

D58 Equipment Matrix Henry Puffer

TOILET ROOM ACCESSORIES	FURNISHED BY	INSTALLED BY
PAPER TOWEL HOLDER	TOILET ROOMS	OWNER
SOAP DISPENSERS	TOILET ROOMS	OWNER
TOILET PAPER HOLDERS	TOILET ROOMS	OWNER
ALL OTHER ACCESSORIES	TOILET ROOMS	CONTRACTOR

TYPICAL DOOR LOCATION

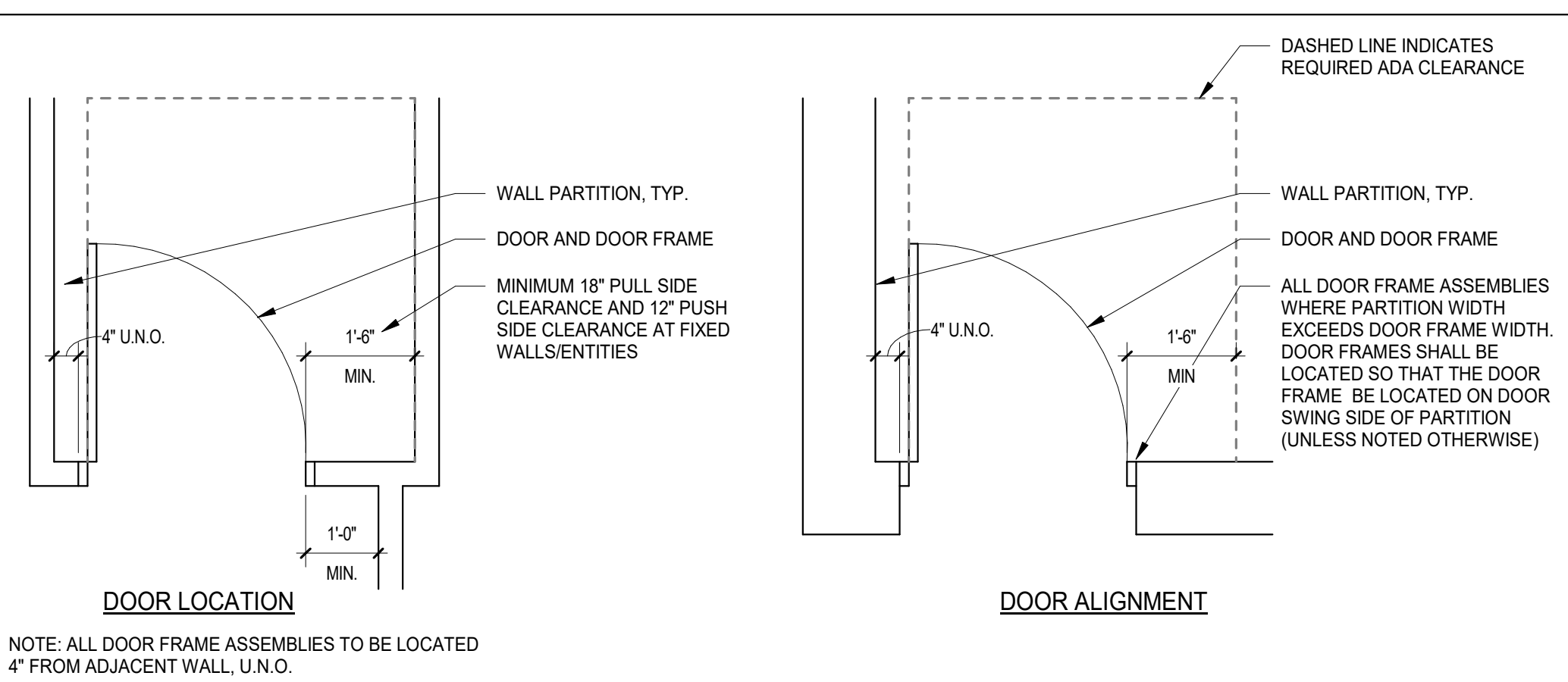

ADA ACCESSIBLE TOILET PLAN & ELEVATIONS

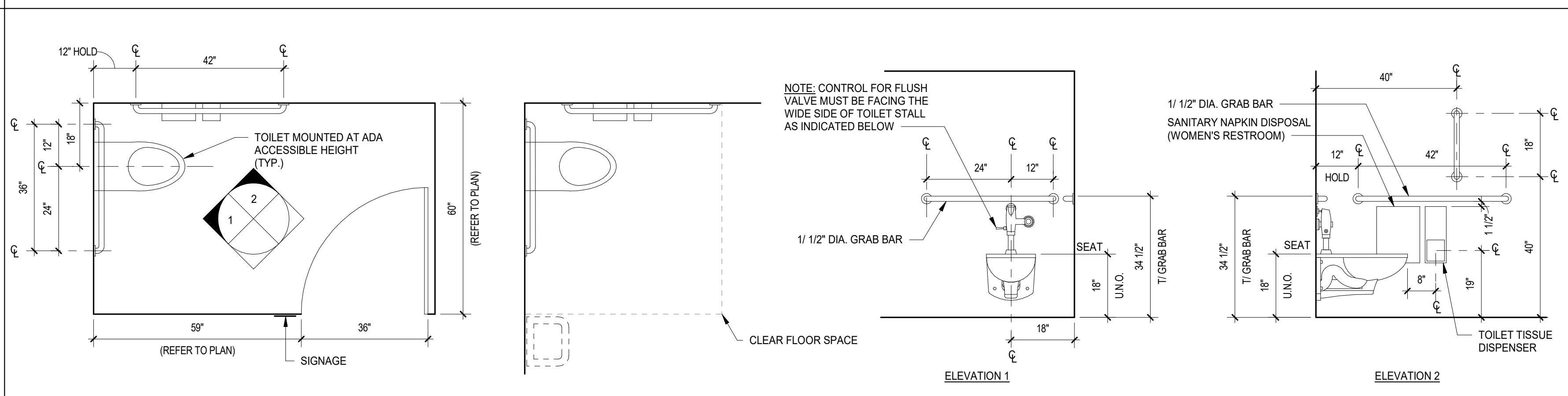

12/12/2023 10:16:29 AM Autodesk Docs/058 EHS Phase 1220281_Henry Puffer_ARCH_2023.rvt Wight & Co. © Copyright 2016 All rights reserved. No part of these documents may be reproduced, stored, or transmitted in any form or by any means, electronic, mechanical, photocopying, recording or otherwise, without the prior written consent of Wight & Co.



Wight
 Wight & Company
 wightco.com
 2500 North Frontage Road
 Darien, IL 60561
 P 630.969.7000
 F 630.969.7979

NOT FOR CONSTRUCTION

E-RATE RFP 12.18.2023
 REV DESCRIPTION DATE

Henry Puffer Elementary School - D58 Referendum Improvements

2220 Haddow Ave
 Downers Grove, IL 60515

GENERAL INFORMATION, SYMBOLS, NOTES & ABBREVIATIONS

Project Number:
 220281
 Drawn By:
 Author
 Sheet:

GO.02

COMMUNICATIONS & LOW VOLTAGE CONDUIT REQUIREMENTS:

ALL CONDUIT RUNS SHALL BE 3/4" EMT, UNLESS NOTED OTHERWISE.

ALL BOXES SHALL BE A MINIMUM OF 4-11/16" x 4-11/16" x 2-1/8" DEEP BOX WITH A SINGLE GANG TRIM RING MOUNTED FLUSH TO THE WALL SURFACE, UNLESS NOTED OTHERWISE.

ALL MOUNTING HEIGHTS ARE TO THE CENTERLINE OF THE BACKBOX UNLESS NOTED OTHERWISE.

ALL CONDUIT SHALL BE ROUTED ABOVE CEILINGS, BELOW FLOORS, OR STUBBED UP WITHIN WALLS; NO CONDUIT SHALL BE EXPOSED UNLESS APPROVED BY THE ARCHITECT.

ALL CONDUITS IN WALLS SHALL STUB UP AT LEAST 6-INCHES ABOVE THE FINISHED CEILING. ALL STUBS SHALL BE REAMED AND BUSHED AT BOTH ENDS.

ALL CONDUIT PENETRATIONS THROUGH FIRE-RATED PARTITIONS SHALL BE SEALED AS REQUIRED BY CODE. ALL BACKBOXES MOUNTED WITHIN FIRE-RATED PARTITIONS SHALL MEET THE FIRE RATING OF THE PARTITION AS REQUIRED BY CODE.

PROVIDE PULL STRINGS IN ALL CONDUIT RUNS LONGER THAN 10-FEET.

PROVIDE PULL BOXES EVERY 100 LINEAR FEET OR AFTER TWO SUCCESSIVE 90° BENDS.

ALL JUNCTION AND PULL BOXES SHALL BE FURNISHED WITH ACCOMPANYING BLANK COVER PLATE.

ALL BOXES IN EXTERIOR LOCATIONS SHALL BE WEATHERPROOF AND WATERPROOF.

INSTRUCTIONS SHOWN IN DIMENSION LINES, DETAILS, ELEVATIONS, AND PLANS (IN THIS ORDER) TAKE PRECEDENCE OVER INSTRUCTIONS SHOWN IN LEGENDS.

CONDUIT AND CABLE ROUTING SHOWN IS SCHEMATIC AND IS NOT INTENDED TO REPRESENT INSTALLATION PATHS OR DISTANCES. ACTUAL ROUTING AND BOX LOCATIONS SHALL BE FIELD-VERIFIED FOR FEASIBILITY AND COORDINATED WITH OTHER DISCIPLINES BY THE INSTALLATION CONTRACTOR.

HORIZONTAL CONDUITS INTO EACH TECHNOLOGY AREA FROM THE EXTERIOR CEILING PLENUM ARE REQUIRED FOR CABLE ACCESS INTO THE ROOM FROM ALL LOCATIONS THROUGHOUT THE SPACE. THE ENDS OF THE CONDUITS SHALL BE REAMED AND BUSHED, AND EXTEND A MINIMUM OF 2-INCHES INTO THE ROOM.

CABLE O.D. (")	CONDUIT TRADE SIZE AND MAXIMUM QUANTITIES OF CABLES OF THAT O.D.						
	3/4"	1"	1-1/4"	1-1/2"	2"	3"	4"
0.16	10	19	33	46	75	200	333
0.18	8	13	23	32	52	139	231
0.20	6	11	19	25	42	112	187
0.25	4	6	12	16	27	71	120
0.27	3	6	10	14	22	60	102
0.30	2	4	8	10	18	48	82
0.33	1	4	6	8	14	40	68
0.35	1	3	6	8	12	36	60
0.38	1	2	5	7	10	30	50
0.40	1	2	4	6	10	28	46
0.45	1	1	3	5	8	22	38
0.50	1	1	2	4	6	16	30
0.55	1	1	1	3	5	14	24
0.60	N/A	1	1	2	4	12	20
0.67	N/A	1	1	1	3	10	16
0.70	N/A	1	1	1	3	8	14
0.75	N/A	N/A	1	1	2	7	12

NUMBER AND SIZE OF CONDUITS	PULL BOX SIZE (W x L x H IN INCHES)	FOR EACH ADDITIONAL CONDUIT ENTERING THE PULL BOX, INCREASE THE WIDTH
ONE 1-INCH	4 X 16 X 3	2 INCHES
ONE 1-1/4-INCH	6 X 20 X 3	3 INCHES
ONE 1-1/2-INCH	8 X 27 X 4	4 INCHES
ONE 2-INCH	8 X 36 X 4	5 INCHES
ONE 4-INCH	15 X 60 X 8	8 INCHES

TECHNOLOGY DRAWING INDEX - E-RATE RFP

- T0.0 - LEGEND AND GENERAL NOTES
- T1.0 - TECHNOLOGY PLAN - LOWER LEVEL AREA A
- T1.1 - TECHNOLOGY PLAN - FIRST FLOOR AREA A
- T1.2 - TECHNOLOGY PLAN - FIRST FLOOR AREA B
- T1.3 - TECHNOLOGY PLAN - FIRST FLOOR AREA C
- T1.4 - TECHNOLOGY PLAN - FIRST FLOOR AREA D

TELECOMMUNICATIONS GROUNDING NOTES:

- REFER TO E-SERIES DRAWINGS FOR PANEL SCHEDULING INFORMATION AND GROUNDING ELECTRODE SYSTEM DATA.
- A SINGLE GROUND SOURCE SHALL BE PROVIDED FOR GROUNDING ALL RACKS, TRAYS AND METAL FRAMES IN THE MAIN DISTRIBUTION FRAME. A TELECOMMUNICATIONS MAIN GROUNDING BUSBAR (TMGB) SHALL BE PROVIDED AND INSTALLED ON THE MAIN CROSS-CONNECT WALL AT A HEIGHT OF 8-FEET AFF. THE TMGB SHALL CONSIST AT A MINIMUM OF A PREDRILLED COPPER BUSBAR WITH HOLES FOR USE WITH STANDARD-SIZED LUGS, AND HAVE MINIMUM DIMENSIONS OF 1/4-INCH THICK BY 4-INCHES WIDE WITH A MINIMUM OF FORTY-EIGHT (48) CONNECTION POINTS. THE TMGB SHALL BE DIRECTLY BONDED TO THE ELECTRICAL SERVICE GROUND AND TO THE BUILDING STEEL.
- A TELECOMMUNICATIONS GROUNDING BUSBAR (TGB) SHALL BE INSTALLED IN ANY/ALL TELECOM ROOMS. THE TGB SHALL BE MOUNTED ON THE HORIZONTAL CROSS-CONNECT WALL AT A HEIGHT OF 8-FEET AFF. THE TGB SHALL CONSIST OF A PREDRILLED COPPER BUSBAR WITH HOLES FOR USE WITH STANDARD-SIZED LUGS, AND HAVE MINIMUM DIMENSIONS OF 1/4-INCH THICK BY 2-INCHES WIDE WITH A MINIMUM OF TWELVE (12) CONNECTION POINTS.
- A GROUND CABLE FROM THE TMGB TO EACH TGB SHALL BE INSTALLED TO CREATE A FORMAL TELECOMMUNICATIONS BONDING BACKBONE (TBB). THE TBB MAY NOT BE DAISY-CHAINED, BUT CAN BE TAPPED-OFF USING A SHORT BONDING CONDUCTOR. BARE COPPER CABLING IS ACCEPTABLE. THE TBB SHALL BE SIZED BASED ON THE LENGTH OF THE CABLE RUN.
- THE CONTRACTOR SHALL PROVIDE AND INSTALL A MINIMUM #6 AWG GROUND WIRE FROM EACH OPEN RELAY RACK AND CABLE TRAY TO THE MAIN TELECOMMUNICATIONS GROUNDING BUSBAR OR TELECOMMUNICATIONS GROUNDING BUSBAR.
- ANY PENETRATION THROUGH A FIRE-RATED WALL SHALL BE PROPERLY FIRE-STOPPED BY THE CONTRACTOR WITH THE APPROPRIATE FIRE-STOP MATERIAL PER APPLICABLE BUILDING AND ELECTRICAL CODES.
- THE CONTRACTOR SHALL COORDINATE GROUND CABLE INSTALLATION WITH THE ARCHITECTS, MEP ENGINEERS AND THE OTHER TRADES ON THE PROJECT.
- THE CONTRACTOR SHALL ASSUME RESPONSIBILITY FOR ANY DAMAGE TO ANY COMPONENT OF THE TELECOMMUNICATIONS GROUNDING SYSTEM DURING INSTALLATION.
- THE CONTRACTOR SHALL VERIFY THAT THE SIZE OF THE TMGB AND THE TGB ARE ADEQUATE TO SUPPORT THE TELECOMMUNICATIONS GROUNDING REQUIREMENTS FOR THE PROJECT.

ANSI/TIA-607-B CONDUCTOR SIZES	
LENGTH IN FEET	CONDUCTOR SIZE (AWG)
LESS THAN 13	6
14 - 20	4
21 - 26	3
27 - 33	2
34 - 41	1
42 - 52	1/0
53 - 66	2/0
67 - 84	3/0
85 - 105	4/0
106 - 125	250 KCMIL
126 - 150	300 KCMIL
151 - 175	350 KCMIL
176 - 250	500 KCMIL
251 - 300	600 KCMIL
GREATER THAN 301	750 KCMIL

ABBREVIATIONS USED IN THESE DRAWINGS:

- AVC = AUDIOVISUAL CABLING CONTRACTOR
- CIC = CABLING INSTALLATION CONTRACTOR
- EC = ELECTRICAL INSTALLATION CONTRACTOR
- PIC = PAGING INSTALLATION CONTRACTOR
- SIC = SECURITY INSTALLATION CONTRACTOR

- X** MOUNTING INFORMATION, WHERE X =
- A ABOVE CEILING
 - D TO THE DESK
 - F FLUSH-MOUNTED
 - H HIDDEN UNDER WORKSURFACE
 - M TO THE MULLION
 - R TO THE RACK ITSELF
 - S PLACED ON THE WORKSURFACE

- AV** MOUNTING INFORMATION, WHERE X =
- A ABOVE CEILING
 - D TO THE DESK
 - F FLUSH-MOUNTED
 - H HIDDEN UNDER WORKSURFACE
 - M TO THE MULLION
 - P TO THE PODIUM
 - R TO THE RACK ITSELF
 - S PLACED ON THE WORKSURFACE
 - TX TRANSMITTER
 - RX RECEIVER

NOTE: COORDINATE WITH THE ARCHITECT AND GENERAL CONTRACTOR FOR EXACT MOUNTING LOCATIONS PRIOR TO INSTALLATION OF ANY COMPONENTS.

THIS DRAWING SERIES IS INTENDED TO SHOW QUANTITIES. REFER TO A-SERIES AND E-SERIES DRAWINGS FOR EXACT LOCATIONS, HEIGHTS, AND PLACEMENT.

NOTE: THIS DRAWING SET INCORPORATES THREE-PART SPECIFICATIONS FOR INTERPRETATION; THEREFORE, THESE SPECIFICATIONS AND DRAWINGS SHALL BE TREATED AS A SINGLE ISSUANCE. IF EITHER COMPONENT IS NOT UTILIZED FOR BID, REVIEW, OR CONSTRUCTION, THEN CRITICAL INFORMATION IS MISSING THAT MAY AFFECT SCHEDULE AND PRICING. INSTALLATION CONTRACTORS SHALL TRANSMIT, DOWNLOAD, AND INCORPORATE THESE SPECIFICATIONS ALONG WITH THESE DRAWINGS.

NOTE: BASE BID WORK IS AS FOLLOWS:

- BASE BID WORK SHALL INCLUDE ALL CABLING LOCATIONS IN THE HIGHLIGHTED AREAS
- ALL CABLING LOCATIONS FOR PAGING SYSTEM, CAMERA, AND WALL DATA LOCATIONS THROUGHOUT THE ENTIRE SCHOOL
- FIBER BACKBONE CABLE

NOTE: ALTERNATE BID WORK IS AS FOLLOWS:

- WIRELESS ACCESS POINT LOCATIONS THROUGHOUT THE ENTIRE SCHOOL NOT IN BASE BID AREAS
- PROJECTOR LOCATIONS THROUGHOUT THE ENTIRE SCHOOL NOT IN BASE BID AREAS

COMMUNICATIONS LEGEND:

- 2** TWO (2) CABLE AND TWO (2) JACK LOCATION. CIC TO FURNISH AND INSTALL TWO (2) CATEGORY 6 CABLES AND TWO (2) CATEGORY 6 8P8C (RJ45) JACKS AT THIS LOCATION. REFER TO THE SPECIFICATION FOR CABLE AND JACK REQUIREMENTS. MOUNT AT +15" AFF. O.C. UNO. CIC TO COORDINATE FACEPLATE FINISH AND HEIGHT WITH ARCHITECTS.
- E** EXISTING DATA LOCATION. CIC TO FURNISH AND INSTALL ONE (1) CATEGORY 6 CABLE AND ONE (1) CATEGORY 6 8P8C (RJ45) JACK AT THIS LOCATION. REFER TO THE SPECIFICATION FOR CABLE AND JACK REQUIREMENTS. CIC TO COORDINATE FACEPLATE FINISH AND HEIGHT WITH ARCHITECTS. PROVIDE FACEPLATE BLANK FOR ANY UNUSED OPENINGS IN THE FACEPLATE.
- D** EXISTING DATA LOCATION TO BE REMOVED. CICTO FURNISH AND INSTALL A BLANK FACEPLATE AT THIS LOCATION TO COVER THE OPENING. CIC TO COORDINATE FACEPLATE FINISH AND HEIGHT WITH ARCHITECTS.
- WAP** CEILING DATA LOCATION CONSISTING OF TWO (2) CATEGORY 6A 8P8C (RJ45) JACKS AND TWO (2) CATEGORY 6 CABLES TO SUPPORT CUSTOMER PROVIDED AND CIC INSTALLED WIRELESS ACCESS POINTS. CIC TO FURNISH AND INSTALL TWO (2) CATEGORY 6A CABLES AND TWO (2) CATEGORY 6A 8P8C (RJ45) JACKS WITH A 25-FOOT SERVICE LOOP AT THIS LOCATION. CIC TO FURNISH AND INSTALL TWO (2) CATEGORY 6A CABLES AND TWO (2) CATEGORY 6A 8P8C (RJ45) MODULAR PLUGS AT END OF THE 25-FOOT SERVICE LOOP COIL. REFER TO THE SPECIFICATION FOR CABLE AND JACK REQUIREMENTS.
- C** CEILING DATA LOCATION CONSISTING OF ONE (1) CATEGORY 6 CABLE TO SUPPORT SIC FURNISHED AND INSTALLED SURVEILLANCE CAMERA. CIC TO FURNISH AND INSTALL ONE (1) CATEGORY 6 CABLE AND ONE (1) CATEGORY 6 8P8C (RJ45) MODULAR PLUG WITH A 3-FOOT SERVICE LOOP AT THIS LOCATION. REFER TO THE SPECIFICATION FOR CABLE REQUIREMENTS.
- C** WALL MOUNTED DATA LOCATION CONSISTING OF ONE (1) CATEGORY 6 CABLE TO SUPPORT SIC FURNISHED AND INSTALLED SURVEILLANCE CAMERA. CIC TO FURNISH AND INSTALL ONE (1) CATEGORY 6 CABLE AND ONE (1) CATEGORY 6 8P8C (RJ45) MODULAR PLUG WITH A 3-FOOT SERVICE LOOP AT THIS LOCATION. REFER TO THE SPECIFICATION FOR CABLE REQUIREMENTS.
- PCL** CIC FURNISHED AND INSTALLED IP-BASED PAGING SPEAKER AND CLOCK. REFER TO THE SPECIFICATION FOR REQUIREMENTS. CIC TO COORDINATE SPEAKER/CLOCK FINISH AND HEIGHT WITH ARCHITECTS.
- CL** CIC FURNISHED AND INSTALLED IP-BASED PAGING DUAL SIDED CLOCK. REFER TO THE SPECIFICATION FOR REQUIREMENTS. CIC TO COORDINATE CLOCK FINISH AND HEIGHT WITH ARCHITECTS.
- PS** CIC FURNISHED AND INSTALLED IP-BASED CEILING MOUNTED PAGING SPEAKER. REFER TO THE SPECIFICATION FOR REQUIREMENTS. CIC TO COORDINATE SPEAKER FINISH AND HEIGHT WITH ARCHITECTS.
- OPS** CIC FURNISHED AND INSTALLED IP-BASED OUTDOOR PAGING SPEAKER. REFER TO THE SPECIFICATION FOR REQUIREMENTS. CIC TO COORDINATE SPEAKER FINISH AND HEIGHT WITH ARCHITECTS.
- ST** CIC FURNISHED AND INSTALLED IP-BASED OUTDOOR STROBE. REFER TO THE SPECIFICATION FOR REQUIREMENTS. CIC TO COORDINATE SPEAKER FINISH AND HEIGHT WITH ARCHITECTS.
- P** CEILING DATA LOCATION CONSISTING OF TWO (2) CATEGORY 6 8P8C (RJ45) JACKS AND TWO (2) CATEGORY 6 CABLES TO SUPPORT CUSTOMER PROVIDED AND INSTALLED PROJECTORS. CIC TO FURNISH AND INSTALL TWO (2) CATEGORY 6 CABLES AND TWO (2) CATEGORY 6 8P8C (RJ45) JACKS WITH A 25-FOOT SERVICE LOOP AT THIS LOCATION. CIC SHALL FURNISH AND INSTALL A PLENUM-RATED TWO-JACK RJ-45 (8P8C) HUBBELL ISB2WP (OR EQUIVALENT) MODULE AT END OF THE 25-FOOT SERVICE LOOP COIL. REFER TO THE SPECIFICATION FOR CABLE AND JACK REQUIREMENTS.
- PS** ONE (1) CABLE AND ONE (1) JACK LOCATION. CIC TO FURNISH AND INSTALL ONE (1) CATEGORY 6 CABLE AND ONE (1) CATEGORY 6 8P8C (RJ45) JACK AT THIS LOCATION TO SUPPORT IP-BASED PAGING SYSTEM SPEAKER AND CLOCK. REFER TO THE SPECIFICATION FOR CABLE AND JACK REQUIREMENTS. CIC TO COORDINATE FACEPLATE FINISH AND HEIGHT WITH ARCHITECTS.
- PS2** TWO (2) CABLE AND TWO (2) JACK LOCATION. CIC TO FURNISH AND INSTALL TWO (2) CATEGORY 6 CABLES AND TWO (2) CATEGORY 6 8P8C (RJ45) JACKS AT THIS LOCATION TO SUPPORT IP-BASED PAGING SYSTEM CLOCK. REFER TO THE SPECIFICATION FOR CABLE AND JACK REQUIREMENTS. CIC TO COORDINATE FACEPLATE FINISH AND HEIGHT WITH ARCHITECTS.
- WAP** TWO (2) CABLE AND TWO (2) JACK LOCATION TO SUPPORT CUSTOMER PROVIDED AND CIC INSTALLED WIRELESS ACCESS POINTS. CIC TO FURNISH AND INSTALL TWO (2) CATEGORY 6A CABLES AND TWO (2) CATEGORY 6A 8P8C (RJ45) JACKS AT THIS LOCATION. REFER TO THE SPECIFICATION FOR CABLE AND JACK REQUIREMENTS. CIC TO COORDINATE FACEPLATE FINISH AND HEIGHT WITH ARCHITECTS.
- 1** ONE (1) CABLE AND ONE (1) JACK LOCATION. CIC TO FURNISH AND INSTALL ONE (1) CATEGORY 6 CABLE AND ONE (1) CATEGORY 6 8P8C (RJ45) JACK AT THIS LOCATION. REFER TO THE SPECIFICATION FOR CABLE AND JACK REQUIREMENTS. MOUNT AT +15" AFF. O.C. UNO. CIC TO COORDINATE FACEPLATE FINISH AND HEIGHT WITH ARCHITECTS.

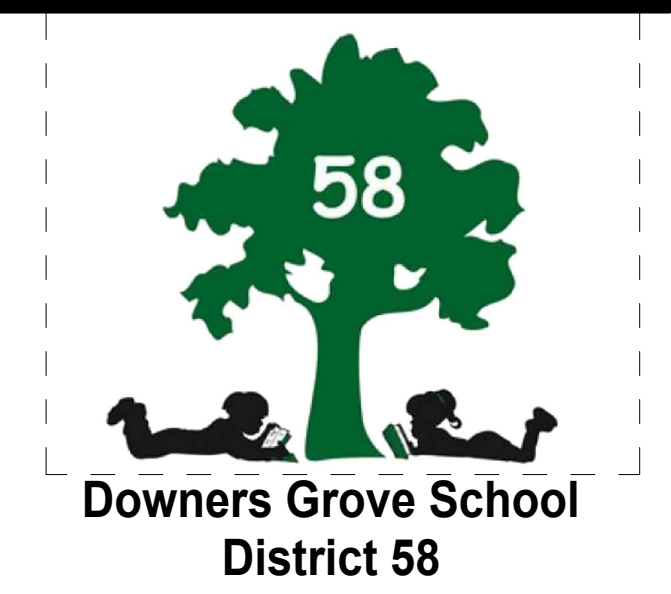

Wight

Wight & Company
wightco.com
2500 North Frontage Road
Darien, IL 60561
P 630.969.7000
F 630.969.7979

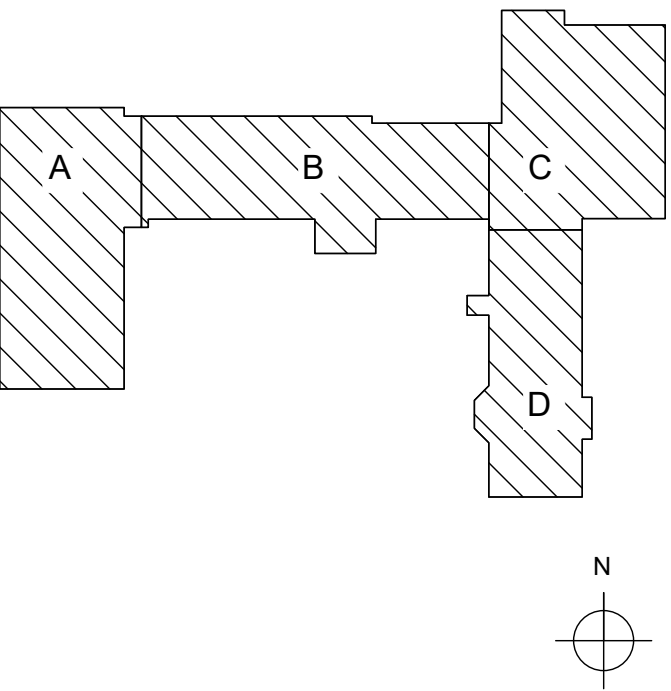

NOT FOR CONSTRUCTION

REV	E-RATE RFP DESCRIPTION	12/18/2023 DATE

HENRY PUFFER ELEMENTARY SCHOOL

2220 HADDOW AVE.
DOWNERS GROVE, IL 60515

LEGEND AND GENERAL NOTES

Project Number:
220281
Drawn By:
-
Sheet:

SENTINEL
2550 WARRENVILLE ROAD
DOWNERS GROVE, ILLINOIS 60515
630.769.4300
www.sentinel.com

Bicsi
REGISTERED COMMUNICATIONS CONTRACTOR
EXPIRES 12/31/23
Reg. No. 119887

T0.0

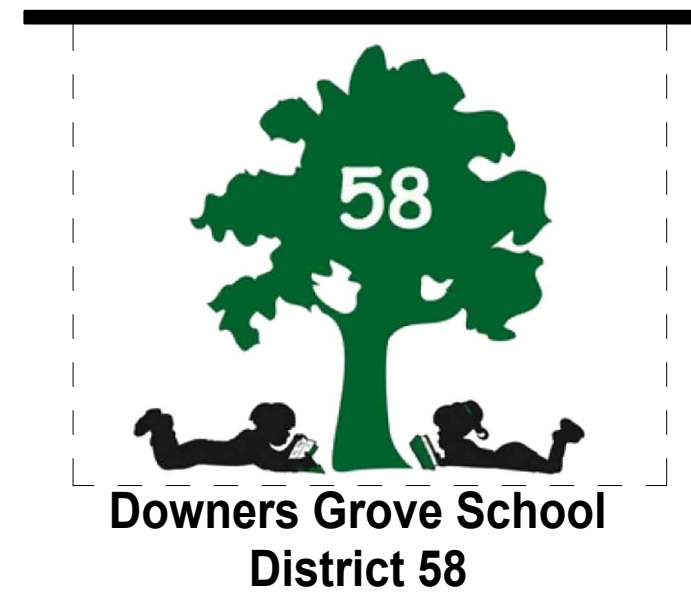
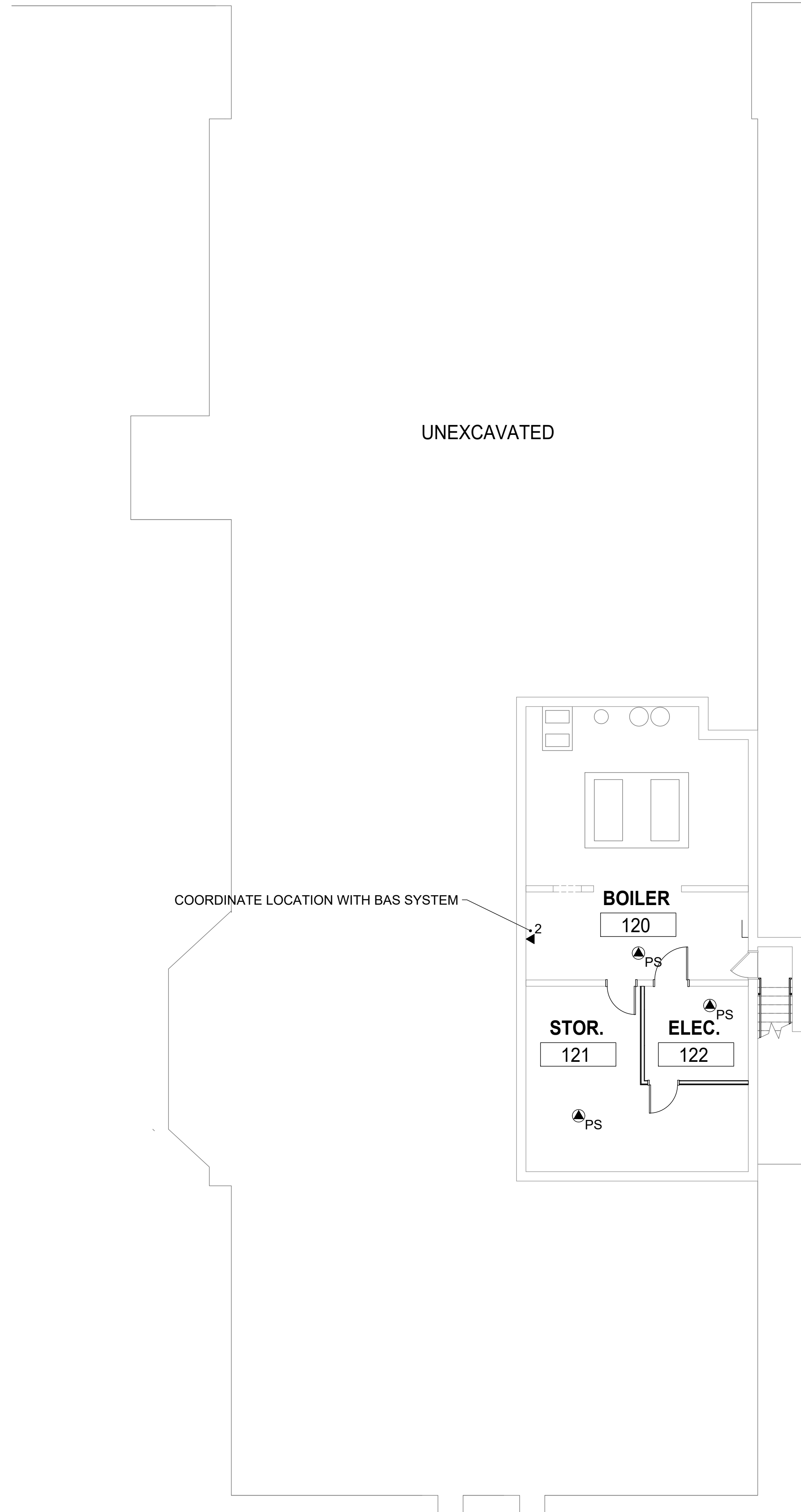
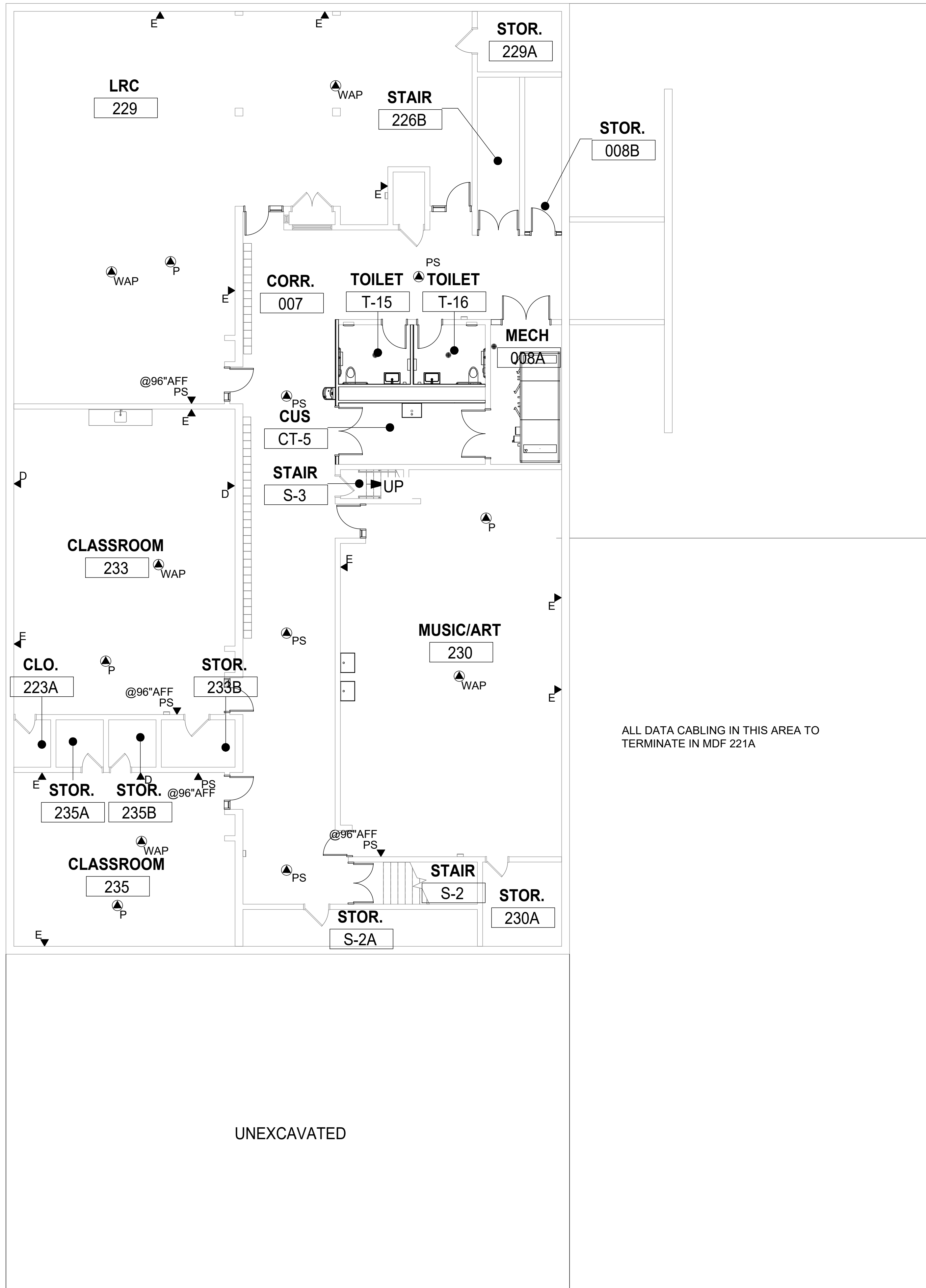

Wight

Wight & Company
 wightco.com
 2500 North Frontage Road
 Darien, IL 60561
 P 630.969.7000
 F 630.969.7979

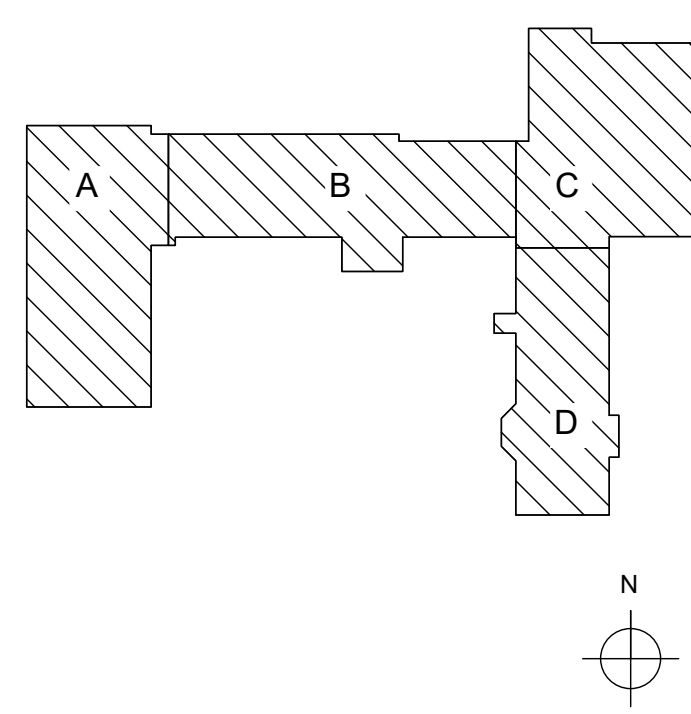

NOT FOR CONSTRUCTION

REV	E-RATE RFP DESCRIPTION	12/18/2023 DATE

HENRY PUFFER ELEMENTARY SCHOOL

2220 HADDOW AVE.
 DOWNERS GROVE, IL 60515
TECHNOLOGY PLAN - LOWER LEVEL AREA A

Project Number: 220281
 Drawn By: -
 Sheet:



T1.0

1 TECHNOLOGY PLAN - AREA A
 PLAN VIEW
 NORTH
 1/8" = 1' - 0"

2 TECHNOLOGY PLAN - AREA D
 PLAN VIEW
 NORTH
 1/8" = 1' - 0"

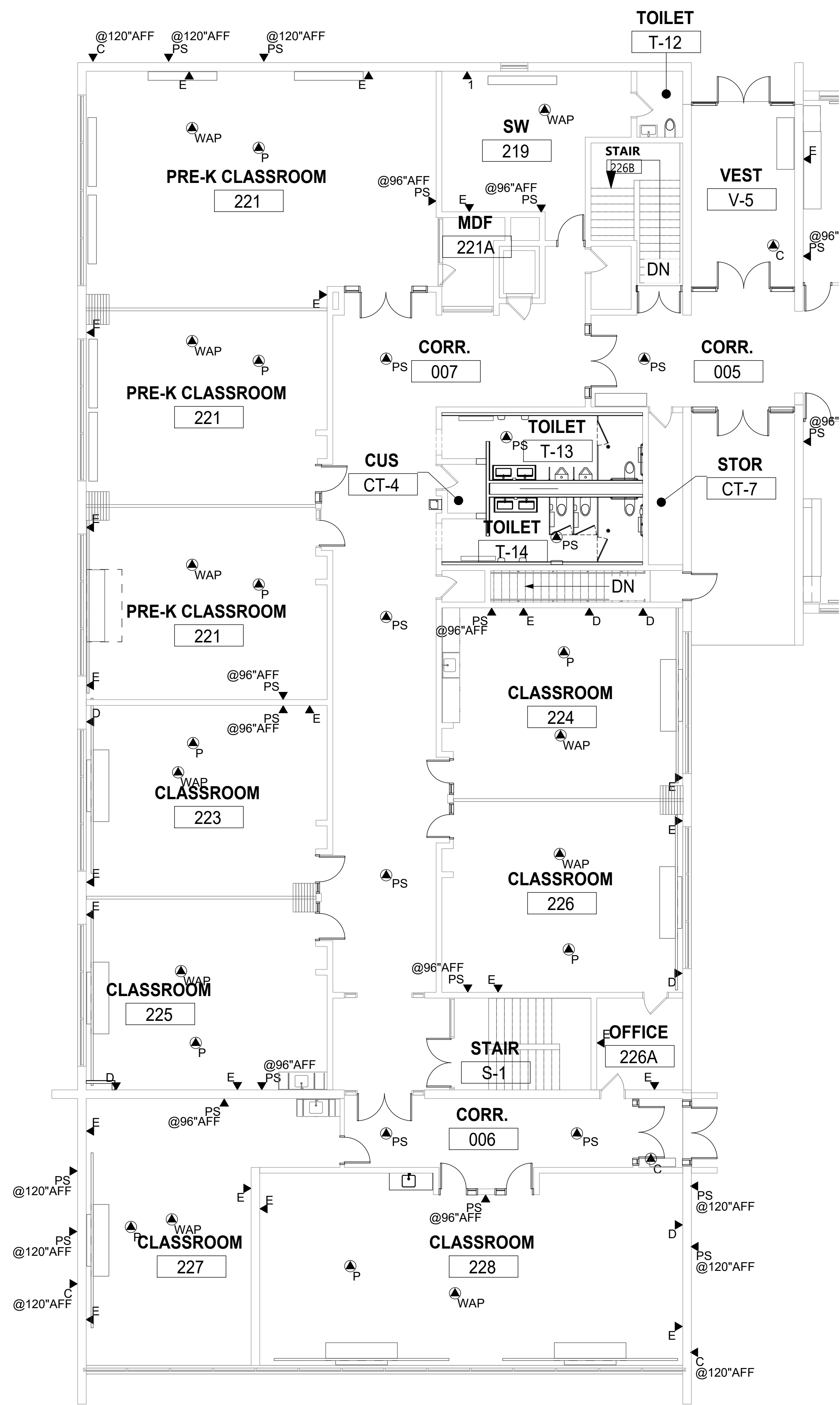

48
47
46
45
44
43
42
41
40
39
38
37
36
35
34
33
32
31
30
29
28
27
26
25
24
23
22
21
20
19
18
17
16
15
14
13
12
11
10
9
8
7
6
5
4
3
2
1

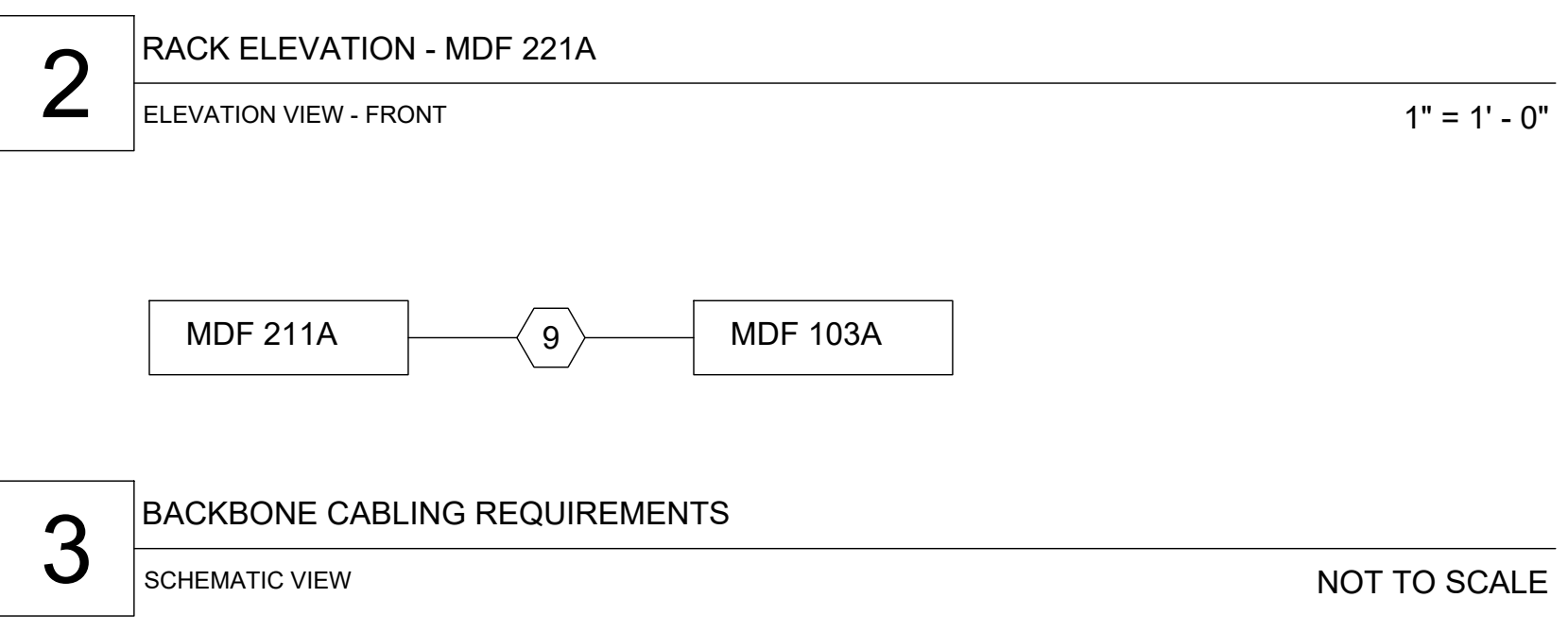
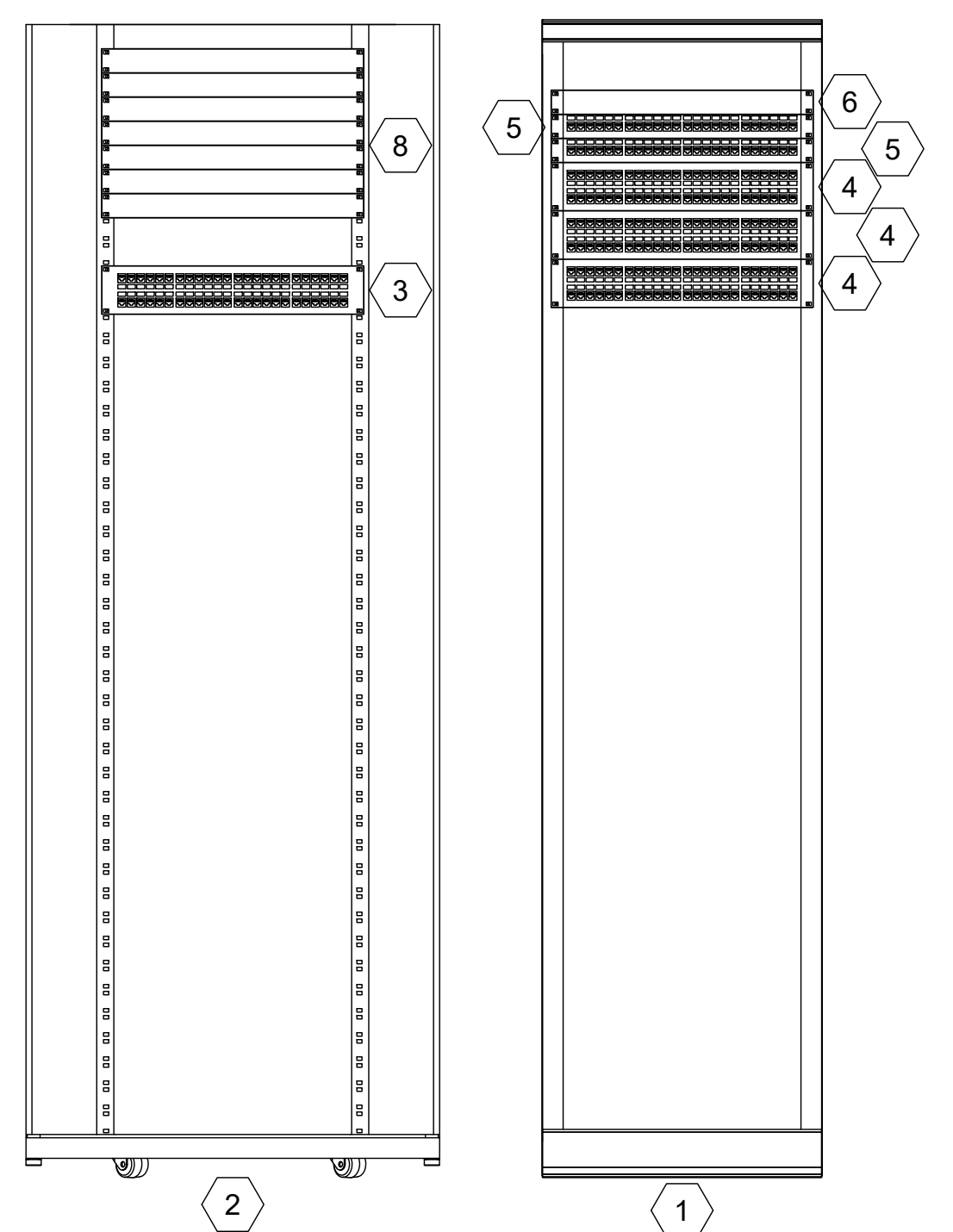

- DRAWING KEYNOTES:**
- 1 EXISTING TO REMAIN 2-POST OPEN RELAY RACK.
 - 2 CIC SUPPLIED AND INSTALLED ENCLOSED EQUIPMENT CABINET TO HOUSE THE PAGING SYSTEM COMPONENTS. CIC TO REMOVE EXISTING 2-POST RACK TO ALLOW FOR THE INSTALLATION OF THE PAGING CABINET.
 - 3 CIC SUPPLIED AND INSTALLED CATEGORY 6 2U 48-PORT PATCH PANEL TO SUPPORT TERMINATION OF HORIZONTAL STATION CABLING FOR PAGING SYSTEM COMPONENTS. REFER TO SPECIFICATION FOR EXACT REQUIREMENTS.
 - 4 CIC SUPPLIED AND INSTALLED CATEGORY 6 2U 48-PORT PATCH PANEL TO SUPPORT TERMINATION OF HORIZONTAL STATION CABLING. REFER TO SPECIFICATION FOR EXACT REQUIREMENTS.
 - 5 CIC SUPPLIED AND INSTALLED CATEGORY 6A 1U 24-PORT PATCH PANEL TO SUPPORT WIRELESS ACCESS POINT CABLING CONNECTIVITY REQUIREMENTS. REFER TO SPECIFICATION FOR EXACT REQUIREMENTS.
 - 6 CIC SUPPLIED AND INSTALLED 1U FIBER OPTIC TERMINATION SHELF TO SUPPORT TERMINATION OF FIBER BACKBONE CABLING. REFER TO SPECIFICATION FOR EXACT REQUIREMENTS.
 - 7 EXISTING TO REMAIN WALL MOUNTED EQUIPMENT RACK. INSTALL COMPONENTS BASED ON ACTUAL RACK SIZE AND FIELD CONDITIONS.
 - 8 CIC SUPPLIED AND INSTALLED PAGING SYSTEM COMPONENTS. REFER TO PAGING SYSTEM DETAILS DRAWING FOR EXACT REQUIREMENTS.
 - 9 LOW VOLTAGE INTEGRATOR SUPPLIED AND INSTALLED QUANTITY ONE (1) 24-STRAND 50-MICRON OM4 GRADE ARMORED FIBER OPTIC CABLE. REFER TO CABLE SPECIFICATION DRAWING FOR EXACT REQUIREMENTS.

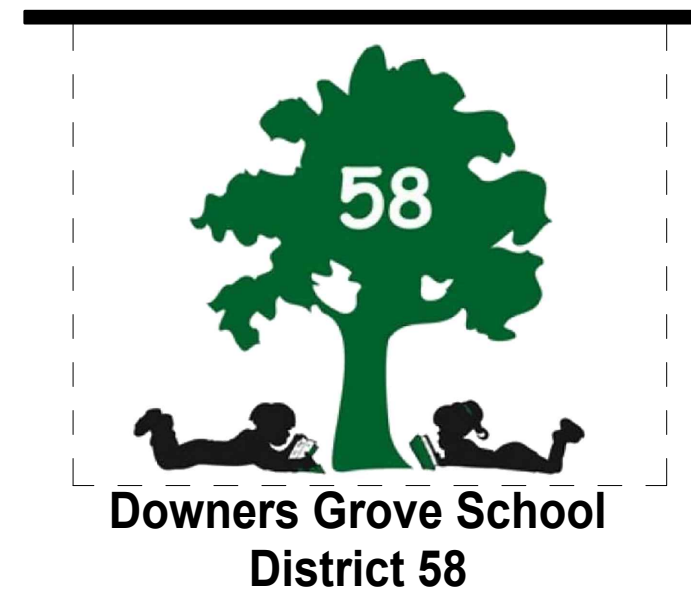

Wight

Wight & Company
wightco.com
2500 North Frontage Road
Darien, IL 60561
P 630.969.7000
F 630.969.7979

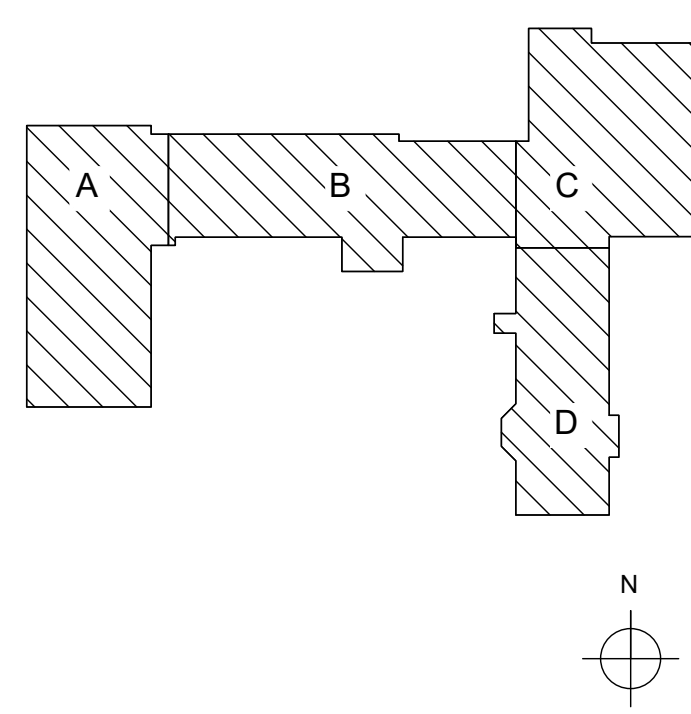

NOT FOR CONSTRUCTION

REV	E-RATE RFP DESCRIPTION	12/18/2023 DATE
-----	------------------------	-----------------

HENRY PUFFER ELEMENTARY SCHOOL

2220 HADDOW AVE.
DOWNERS GROVE, IL 60515
TECHNOLOGY PLAN - FIRST FLOOR AREA A

Project Number: 220281
Drawn By: -
Sheet: -



T1.1



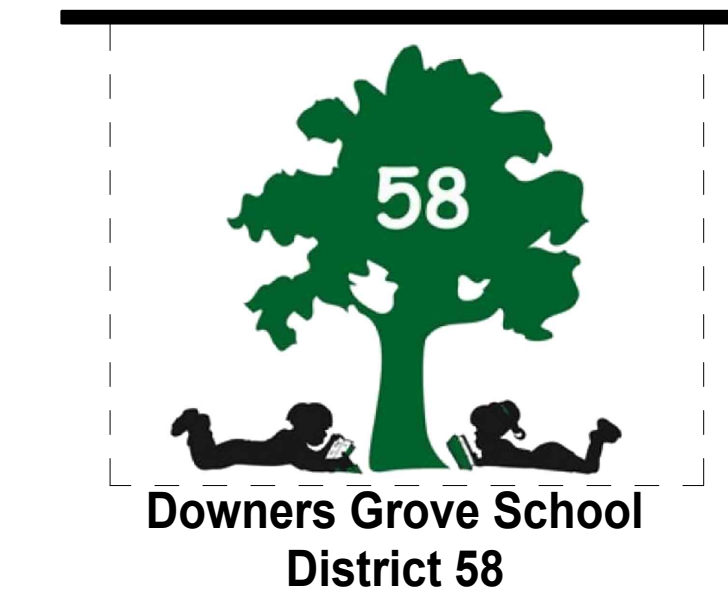
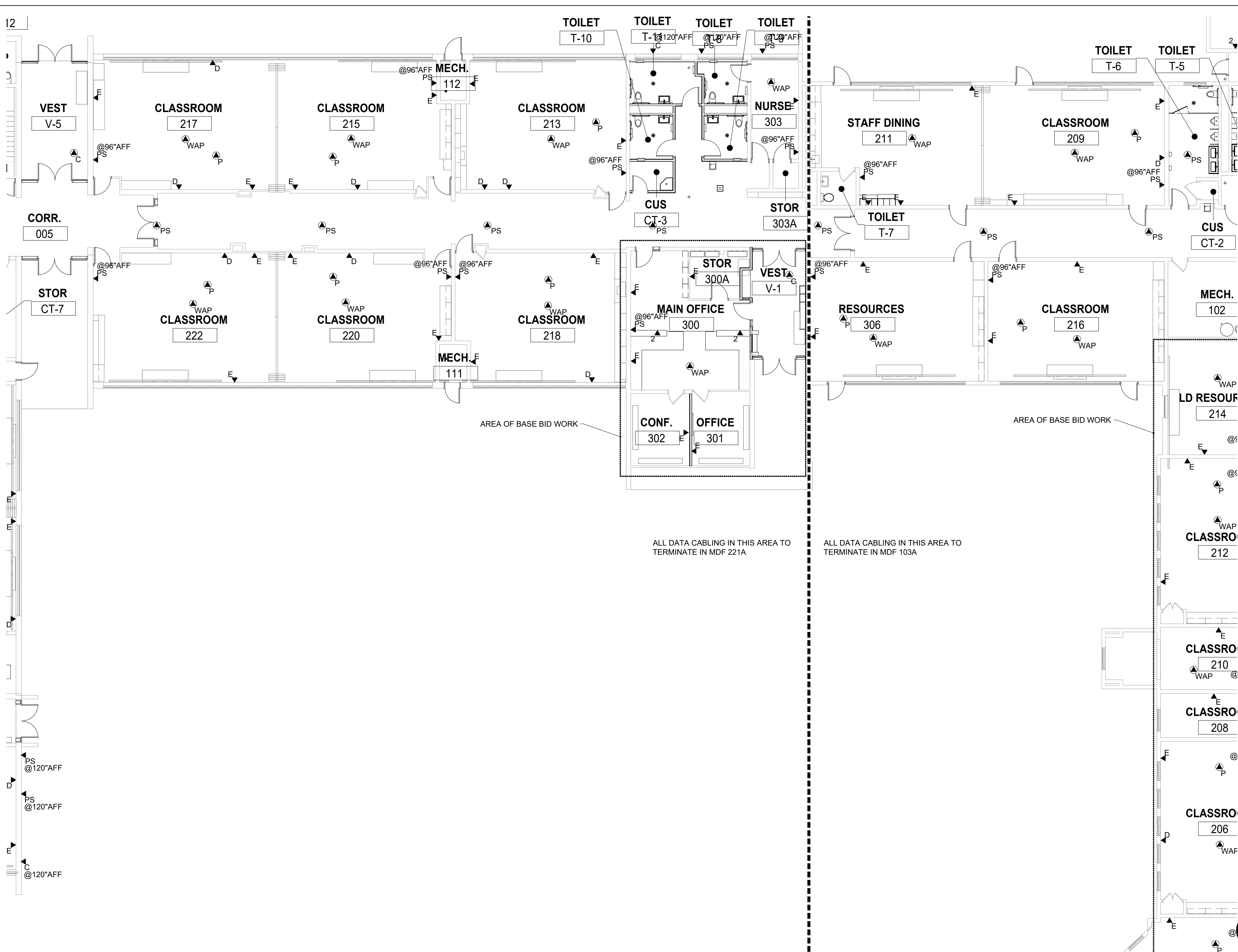

Wight

Wight & Company
 wightco.com
 2500 North Frontage Road
 Darien, IL 60561
 P 630.969.7000
 F 630.969.7979

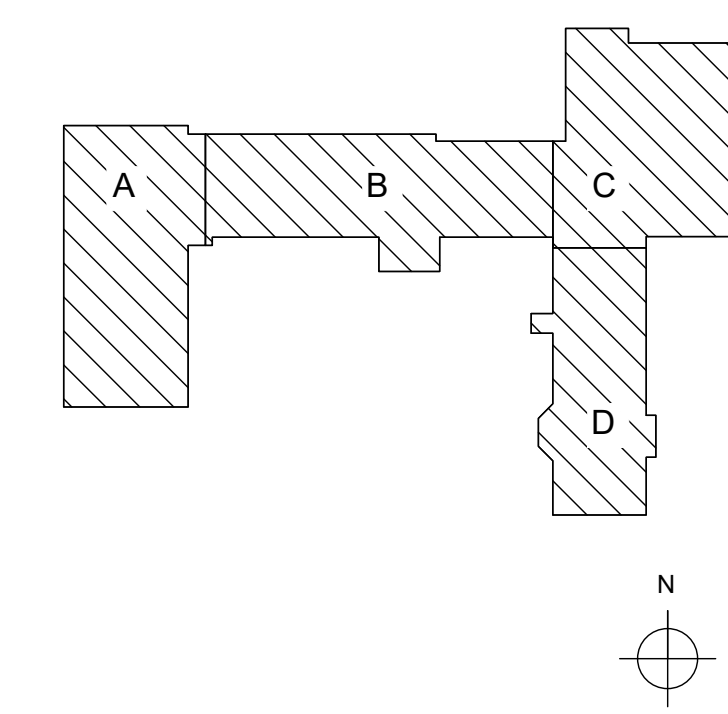

NOT FOR CONSTRUCTION

REV	E-RATE RFP DESCRIPTION	12/18/2023 DATE
-----	------------------------	-----------------

HENRY PUFFER ELEMENTARY SCHOOL

2220 HADDOW AVE.
 DOWNERS GROVE, IL 60515
TECHNOLOGY PLAN - FIRST FLOOR AREA B

Project Number: 220281
 Drawn By:
 Sheet:

SENTINEL
 2550 WARRENVILLE ROAD
 DOWNERS GROVE, ILLINOIS 60515
 630.769.4300
 www.sentinel.com

Bicsi
 REGISTERED COMMUNICATIONS CONTRACTOR
 EXPIRES 12/31/23
 Reg. No. 119887

T1.2



Wight

Wight & Company
wightco.com
2500 North Frontage Road
Darien, IL 60561
P 630.969.7000
F 630.969.7979

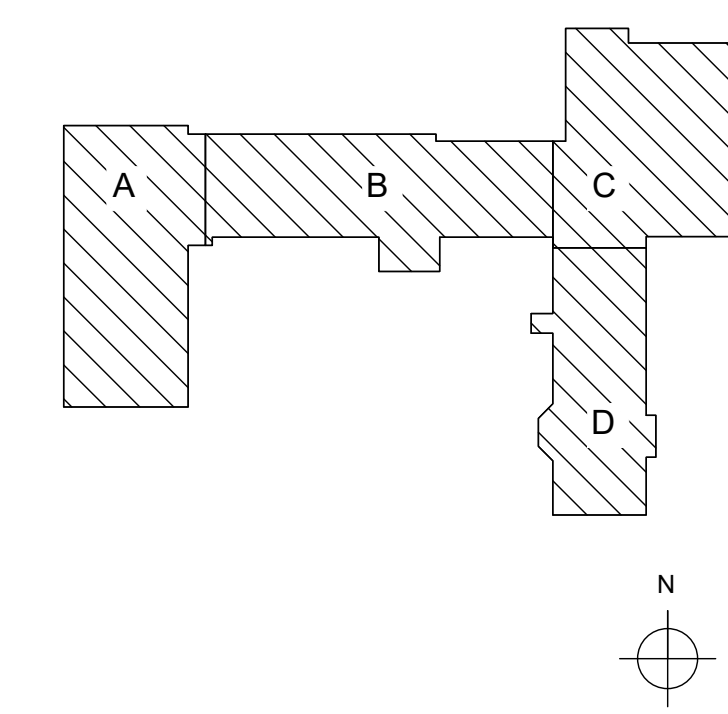

NOT FOR CONSTRUCTION

REV	E-RATE RFP DESCRIPTION	12/18/2023 DATE

HENRY PUFFER ELEMENTARY SCHOOL

2220 HADDOW AVE.
DOWNERS GROVE, IL 60515

TECHNOLOGY PLAN - FIRST FLOOR AREA C

Project Number:
220281
Drawn By:
-
Sheet:

T1.3

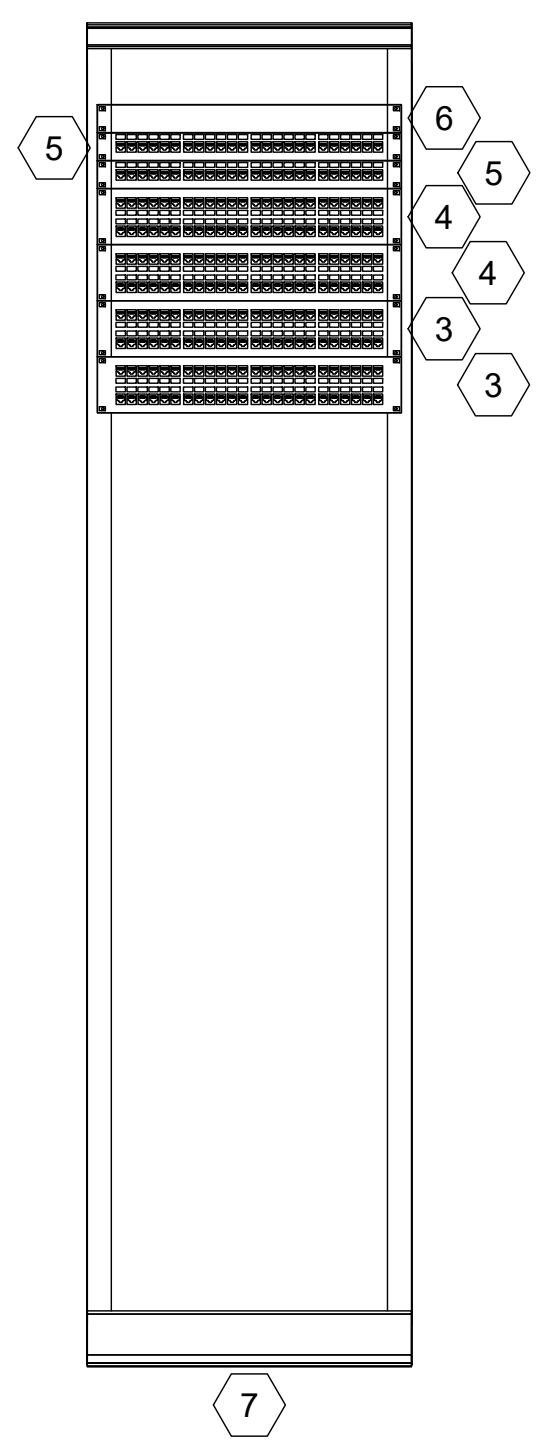

2 RACK ELEVATION - MDF 103A
ELEVATION VIEW - FRONT
1" = 1' - 0"

DRAWING KEYNOTES:

- 1 EXISTING TO REMAIN 2-POST OPEN RELAY RACK.
- 2 CIC SUPPLIED AND INSTALLED ENCLOSED EQUIPMENT CABINET TO HOUSE THE PAGING SYSTEM COMPONENTS. CIC TO REMOVE EXISTING 2-POST RACK TO ALLOW FOR THE INSTALLATION OF THE PAGING CABINET.
- 3 CIC SUPPLIED AND INSTALLED CATEGORY 6 2U 48-PORT PATCH PANEL TO SUPPORT TERMINATION OF HORIZONTAL STATION CABLING FOR PAGING SYSTEM COMPONENTS. REFER TO SPECIFICATION FOR EXACT REQUIREMENTS.
- 4 CIC SUPPLIED AND INSTALLED CATEGORY 6 2U 48-PORT PATCH PANEL TO SUPPORT TERMINATION OF HORIZONTAL STATION CABLING. REFER TO SPECIFICATION FOR EXACT REQUIREMENTS.
- 5 CIC SUPPLIED AND INSTALLED CATEGORY 6A 1U 24-PORT PATCH PANEL TO SUPPORT WIRELESS ACCESS POINT CABLING CONNECTIVITY REQUIREMENTS. REFER TO SPECIFICATION FOR EXACT REQUIREMENTS.
- 6 CIC SUPPLIED AND INSTALLED 1U FIBER OPTIC TERMINATION SHELF TO SUPPORT TERMINATION OF FIBER BACKBONE CABLING. REFER TO SPECIFICATION FOR EXACT REQUIREMENTS.
- 7 EXISTING TO REMAIN WALL MOUNTED EQUIPMENT RACK. INSTALL COMPONENTS BASED ON ACTUAL RACK SIZE AND FIELD CONDITIONS.
- 8 CIC SUPPLIED AND INSTALLED PAGING SYSTEM COMPONENTS. REFER TO PAGING SYSTEM DETAILS DRAWING FOR EXACT REQUIREMENTS.
- 9 LOW VOLTAGE INTEGRATOR SUPPLIED AND INSTALLED QUANTITY ONE (1) 24-STRAND 50-MICRON OM4 GRADE ARMORED FIBER OPTIC CABLE. REFER TO CABLE SPECIFICATION DRAWING FOR EXACT REQUIREMENTS.

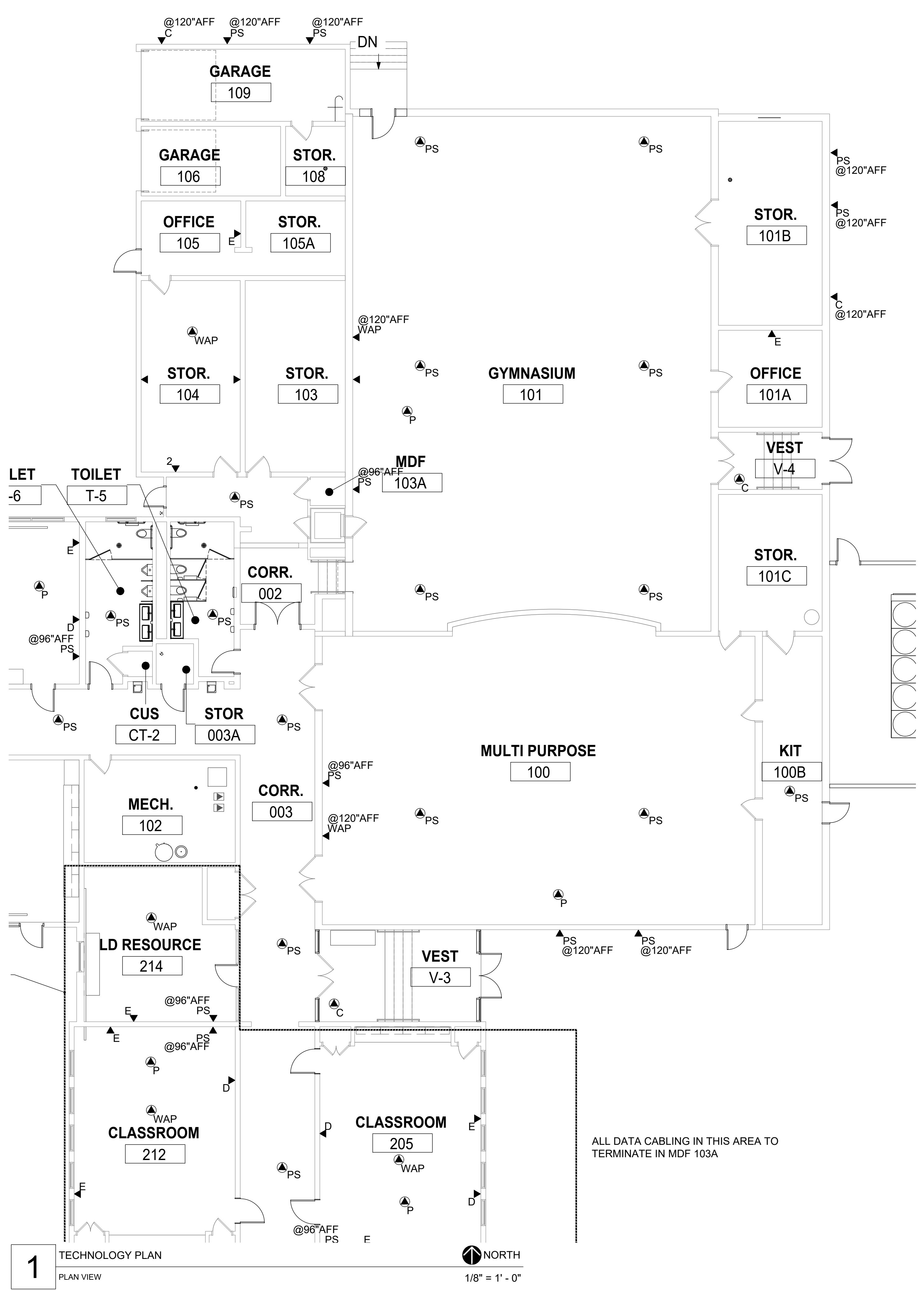

ALL DATA CABLING IN THIS AREA TO TERMINATE IN MDF 103A

1 TECHNOLOGY PLAN
PLAN VIEW
1/8" = 1' - 0"

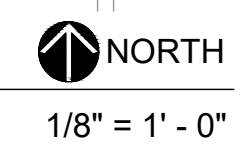

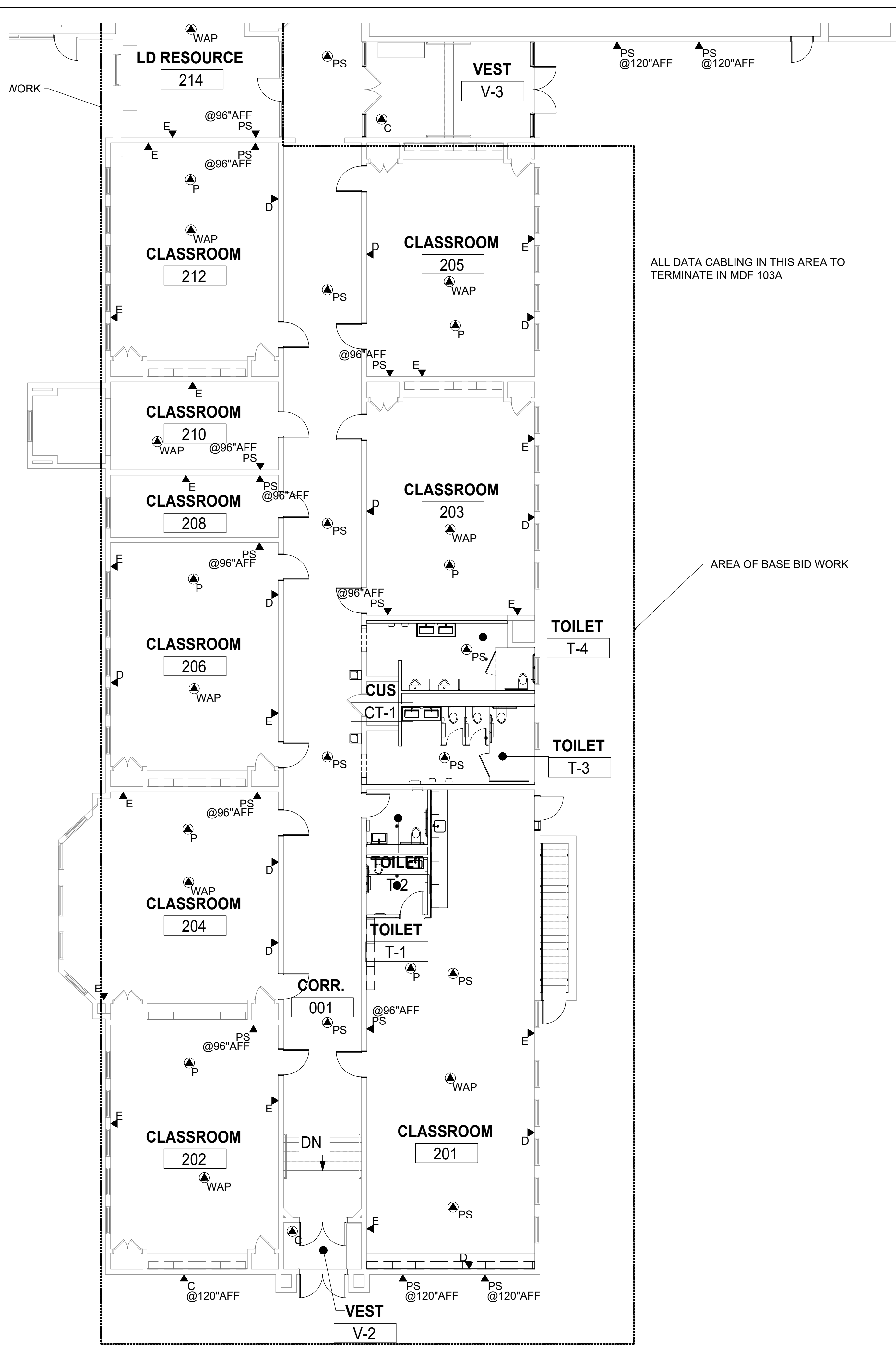

ALL DATA CABLING IN THIS AREA TO TERMINATE IN MDF 103A

AREA OF BASE BID WORK

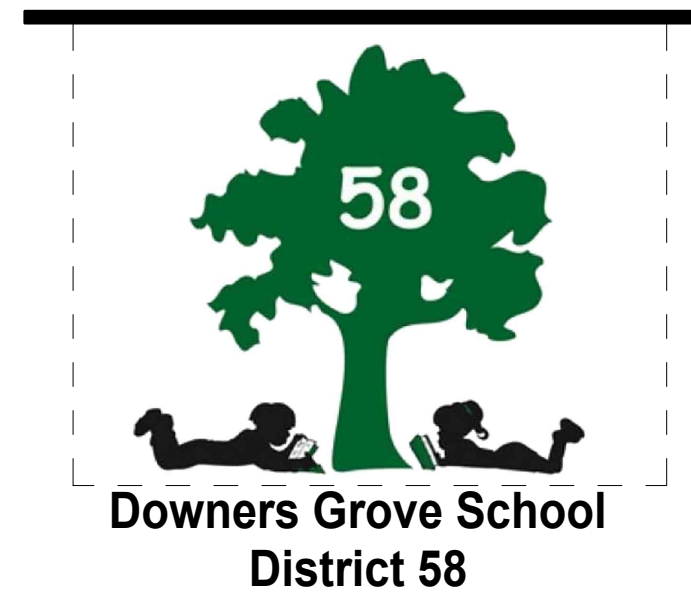

Downers Grove School
District 58

Wight

Wight & Company
wightco.com
2500 North Frontage Road
Darien, IL 60561
P 630.969.7000
F 630.969.7979

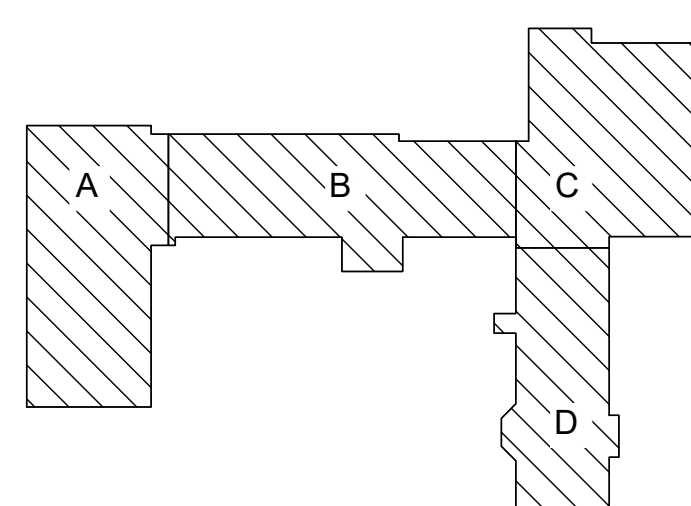

**NOT FOR
CONSTRUCTION**

REV	E-RATE RFP DESCRIPTION	12/18/2023 DATE
-----	------------------------	-----------------

HENRY PUFFER ELEMENTARY SCHOOL

2220 HADDOW AVE.
DOWNERS GROVE, IL 60515

TECHNOLOGY PLAN - FIRST FLOOR AREA D

Project Number:
220281
Drawn By:
-
Sheet:

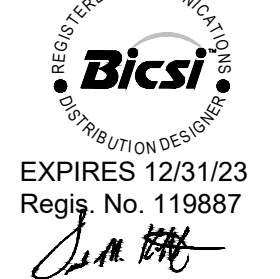

T1.4

1

TECHNOLOGY PLAN
PLAN VIEW

NORTH
1/8" = 1' - 0"

Highland Elementary School - D58 Referendum Improvements

Downers Grove School District 58

3935 Highland Ave

Downers Grove, IL 60515

220281

December 18, 2023

NOT FOR CONSTRUCTION

ISSUED FOR E-RATE RFP

PROJECT TEAM		DRAWING SHEET INDEX		LOCATION																																																				
<p>CLIENT DOWNERS GROVE GRADE SCHOOL DISTRICT 58 2300 WARRENVILLE RD, SUITE 200 NE DOWNERS GROVE, IL 60516 PHONE: (630)719-5858 CONTACT: KEVIN BARTO</p> <p>STRUCTURAL ENGINEER WIGHT & COMPANY 2500 NORTH FRONTAGE ROAD DARIEN, IL 60561 PHONE: (630)969-7000 FAX: (630)969-7979 CONTACT: MATT AQUINO Design Firm Registration #184-000451</p> <p>TECHNOLOGY SERVICES SENTINEL TECHNOLOGIES 2550 WARRENVILLE RD. DOWNERS GROVE, IL 60515 PHONE: (630) 769-4284 CONTACT: FRANK KRISTOFF</p>	<p>ARCHITECT WIGHT & COMPANY 2500 NORTH FRONTAGE ROAD DARIEN, IL 60561 PHONE: (630)969-7000 FAX: (630)969-7979 CONTACT: AMY TIBERI Design Firm Registration #184-000451</p> <p>PLUMBING & FIRE PROTECTION ENGINEER WIGHT & COMPANY 2500 NORTH FRONTAGE ROAD DARIEN, IL 60561 PHONE: (630)969-7000 FAX: (630)969-7979 CONTACT: BILL BAUER Design Firm Registration #184-000451</p> <p>MECHANICAL ENGINEER WIGHT & COMPANY 2500 NORTH FRONTAGE ROAD DARIEN, IL 60561 PHONE: (630)969-7000 FAX: (630)969-7979 CONTACT: SUDESH SARAF Design Firm Registration #184-000451</p> <p>ELECTRICAL ENGINEER WIGHT & COMPANY 2500 NORTH FRONTAGE ROAD DARIEN, IL 60561 PHONE: (630)969-7000 FAX: (630)969-7979 CONTACT: ANTHONY SULLENTRUP Design Firm Registration #184-000451</p>	<p>BUILDING CODE DATA</p> <p>1. APPLICABLE CODES</p> <table border="0"> <tr> <td>BUILDING CODE:</td> <td>2015 INTERNATIONAL EXISTING BUILDING CODE</td> </tr> <tr> <td>MECHANICAL CODE:</td> <td>2015 INTERNATIONAL MECHANICAL CODE</td> </tr> <tr> <td>ELECTRICAL CODE:</td> <td>2014 NATIONAL ELECTRICAL CODE</td> </tr> <tr> <td>PLUMBING CODE:</td> <td>ILLINOIS PLUMBING CODE - CURRENT EDITION</td> </tr> <tr> <td>ACCESSIBILITY CODE:</td> <td>2018 ILLINOIS ACCESSIBILITY CODE</td> </tr> <tr> <td>ENERGY CODE:</td> <td>2018 INTERNATIONAL ENERGY CONSERVATION</td> </tr> <tr> <td>FIRE CODE:</td> <td>2015 INTERNATIONAL FIRE CODE</td> </tr> <tr> <td>OTHER CODES:</td> <td>2015 IBC FUEL GAS CODE</td> </tr> </table> <p>2. GENERAL BUILDING DESCRIPTION</p> <table border="0"> <tr> <td>GROSS BUILDING AREA, EXISTING:</td> <td>34,148 SF</td> </tr> <tr> <td>GROSS BUILDING AREA, TOTAL (NEW & EXISTING):</td> <td>34,148 SF</td> </tr> </table> <p>3. BUILDING OCCUPANCY TYPE</p> <table border="0"> <tr> <td>OCCUPANCY CLASSIFICATION:</td> <td>SECTION 302</td> </tr> <tr> <td></td> <td>E</td> </tr> </table> <p>4. CONSTRUCTION TYPE</p> <table border="0"> <tr> <td>CONSTRUCTION TYPE:</td> <td>SECTION 503, 602</td> </tr> <tr> <td>FIRE RESISTANCE RATING REQUIREMENTS</td> <td>TABLE 601</td> </tr> <tr> <td>STRUCTURAL FRAME:</td> <td>0 HR</td> </tr> <tr> <td>BEARING WALLS (EXTERIOR) (ALSO SEE TABLE 602):</td> <td>0 HR</td> </tr> <tr> <td>BEARING WALLS (INTERIOR):</td> <td>0 HR</td> </tr> <tr> <td>NON-BEARING WALLS (EXTERIOR):</td> <td>SEE TABLE 602</td> </tr> <tr> <td>NON-BEARING WALLS (INTERIOR):</td> <td>0 HR</td> </tr> <tr> <td>FLOOR CONSTRUCTION:</td> <td>0 HR</td> </tr> <tr> <td>ROOF CONSTRUCTION:</td> <td>0 HR</td> </tr> <tr> <td>EXTERIOR WALL FIRE SEPARATION DISTANCE</td> <td>TABLE 602</td> </tr> <tr> <td>LESS THAN 5'</td> <td>1 HR</td> </tr> <tr> <td>LESS THAN OR EQUAL TO 5' TO LESS THAN 10'</td> <td>1 HR</td> </tr> <tr> <td>LESS THAN OR EQUAL TO 10' TO LESS THAN 30'</td> <td>0 HR</td> </tr> <tr> <td>GREATER THAN OR EQUAL TO 30'</td> <td>0 HR</td> </tr> </table> <p>ADDITIONAL CODE</p> <p>IEBC CHAPTER 4 PRESCRIPTIVE COMPLIANCE PATH DICTATE WHERE FIRE RATING WILL BE REQUIRED</p> <p>COMMON PATH OF EGRESS - 75 FEET MAX.</p> <p>MAX TRAVEL DISTANCE - 200 FEET</p>	BUILDING CODE:	2015 INTERNATIONAL EXISTING BUILDING CODE	MECHANICAL CODE:	2015 INTERNATIONAL MECHANICAL CODE	ELECTRICAL CODE:	2014 NATIONAL ELECTRICAL CODE	PLUMBING CODE:	ILLINOIS PLUMBING CODE - CURRENT EDITION	ACCESSIBILITY CODE:	2018 ILLINOIS ACCESSIBILITY CODE	ENERGY CODE:	2018 INTERNATIONAL ENERGY CONSERVATION	FIRE CODE:	2015 INTERNATIONAL FIRE CODE	OTHER CODES:	2015 IBC FUEL GAS CODE	GROSS BUILDING AREA, EXISTING:	34,148 SF	GROSS BUILDING AREA, TOTAL (NEW & EXISTING):	34,148 SF	OCCUPANCY CLASSIFICATION:	SECTION 302		E	CONSTRUCTION TYPE:	SECTION 503, 602	FIRE RESISTANCE RATING REQUIREMENTS	TABLE 601	STRUCTURAL FRAME:	0 HR	BEARING WALLS (EXTERIOR) (ALSO SEE TABLE 602):	0 HR	BEARING WALLS (INTERIOR):	0 HR	NON-BEARING WALLS (EXTERIOR):	SEE TABLE 602	NON-BEARING WALLS (INTERIOR):	0 HR	FLOOR CONSTRUCTION:	0 HR	ROOF CONSTRUCTION:	0 HR	EXTERIOR WALL FIRE SEPARATION DISTANCE	TABLE 602	LESS THAN 5'	1 HR	LESS THAN OR EQUAL TO 5' TO LESS THAN 10'	1 HR	LESS THAN OR EQUAL TO 10' TO LESS THAN 30'	0 HR	GREATER THAN OR EQUAL TO 30'	0 HR	<p>GENERAL G0.00 G0.02</p> <p>TECHNOLOGY T0.0 T1.0 T1.1 T1.2 T1.3</p> <p>COVER SHEET GENERAL INFORMATION, SYMBOLS, NOTES & ABBREVIATIONS</p> <p>LEGEND AND GENERAL NOTES TECHNOLOGY PLAN - AREA A TECHNOLOGY PLAN - AREA B TECHNOLOGY PLAN - AREA C MDF PLAN</p>	
BUILDING CODE:	2015 INTERNATIONAL EXISTING BUILDING CODE																																																							
MECHANICAL CODE:	2015 INTERNATIONAL MECHANICAL CODE																																																							
ELECTRICAL CODE:	2014 NATIONAL ELECTRICAL CODE																																																							
PLUMBING CODE:	ILLINOIS PLUMBING CODE - CURRENT EDITION																																																							
ACCESSIBILITY CODE:	2018 ILLINOIS ACCESSIBILITY CODE																																																							
ENERGY CODE:	2018 INTERNATIONAL ENERGY CONSERVATION																																																							
FIRE CODE:	2015 INTERNATIONAL FIRE CODE																																																							
OTHER CODES:	2015 IBC FUEL GAS CODE																																																							
GROSS BUILDING AREA, EXISTING:	34,148 SF																																																							
GROSS BUILDING AREA, TOTAL (NEW & EXISTING):	34,148 SF																																																							
OCCUPANCY CLASSIFICATION:	SECTION 302																																																							
	E																																																							
CONSTRUCTION TYPE:	SECTION 503, 602																																																							
FIRE RESISTANCE RATING REQUIREMENTS	TABLE 601																																																							
STRUCTURAL FRAME:	0 HR																																																							
BEARING WALLS (EXTERIOR) (ALSO SEE TABLE 602):	0 HR																																																							
BEARING WALLS (INTERIOR):	0 HR																																																							
NON-BEARING WALLS (EXTERIOR):	SEE TABLE 602																																																							
NON-BEARING WALLS (INTERIOR):	0 HR																																																							
FLOOR CONSTRUCTION:	0 HR																																																							
ROOF CONSTRUCTION:	0 HR																																																							
EXTERIOR WALL FIRE SEPARATION DISTANCE	TABLE 602																																																							
LESS THAN 5'	1 HR																																																							
LESS THAN OR EQUAL TO 5' TO LESS THAN 10'	1 HR																																																							
LESS THAN OR EQUAL TO 10' TO LESS THAN 30'	0 HR																																																							
GREATER THAN OR EQUAL TO 30'	0 HR																																																							

ILLINOIS ENERGY CONSERVATION CODE STATEMENT OF COMPLIANCE

I HAVE PREPARED OR CAUSED TO BE PREPARED UNDER MY DIRECT SUPERVISION, THE ATTACHED PLANS AND SPECIFICATIONS AND STATE THAT, TO THE BEST OF MY KNOWLEDGE AND BELIEF AND TO THE EXTENT OF MY CONTRACTUAL OBLIGATION, THEY ARE IN COMPLIANCE WITH THE REQUIREMENTS OF THE 2015 ILLINOIS ENERGY CONSERVATION CODE

SIGNED: _____

ILLINOIS REGISTRATION NO.: _____

DATE: _____

ARCHITECT

SEAL & SIGNATURE APPLY TO GENERAL AND ARCHITECTURAL SHEETS INDICATED ON G0.01 SHEET AS G, A-SERIES, AND INCLUDED IN THE PERMIT DOCUMENTS.

SIGNED: _____

ILLINOIS REGISTRATION NO.: _____

DATE: _____

STATEMENT OF COMPLIANCE

I HAVE PREPARED OR CAUSED TO BE PREPARED UNDER MY DIRECT SUPERVISION, THE ATTACHED PLANS AND SPECIFICATIONS AND STATE THAT, TO THE BEST OF MY KNOWLEDGE AND BELIEF AND TO THE EXTENT OF MY CONTRACTUAL OBLIGATION, THEY ARE IN COMPLIANCE WITH THE ENVIRONMENTAL BARRIERS ACT (IL. REV. STAT. 1985, CH. 111 1/2, PARS. 3711 ET SEQ AS AMENDED) AND THE ILLINOIS ACCESSIBILITY CODE, 71 IL ADM. CODE 400.

SIGNED: _____

ARCHITECT/ENGINEER

ILLINOIS REGISTRATION NO.: _____

DATE: _____

FOR UNDERGROUND UTILITY LOCATIONS, CALL J.U.L.I.E.

TOLL FREE TEL. 1-800-892-0123
JULIE SUBURBS & DIGG CHICAGO

- YELLOW _____ GAS
- RED _____ ELECTRICAL
- ORANGE _____ PHONE / TV COMMUNICATION
- BLUE _____ WATER
- GREEN _____ SEWERS
- WHITE _____ SAFE TO DIG

TYPICAL FIXTURE MOUNTING HEIGHTS, U.N.O.

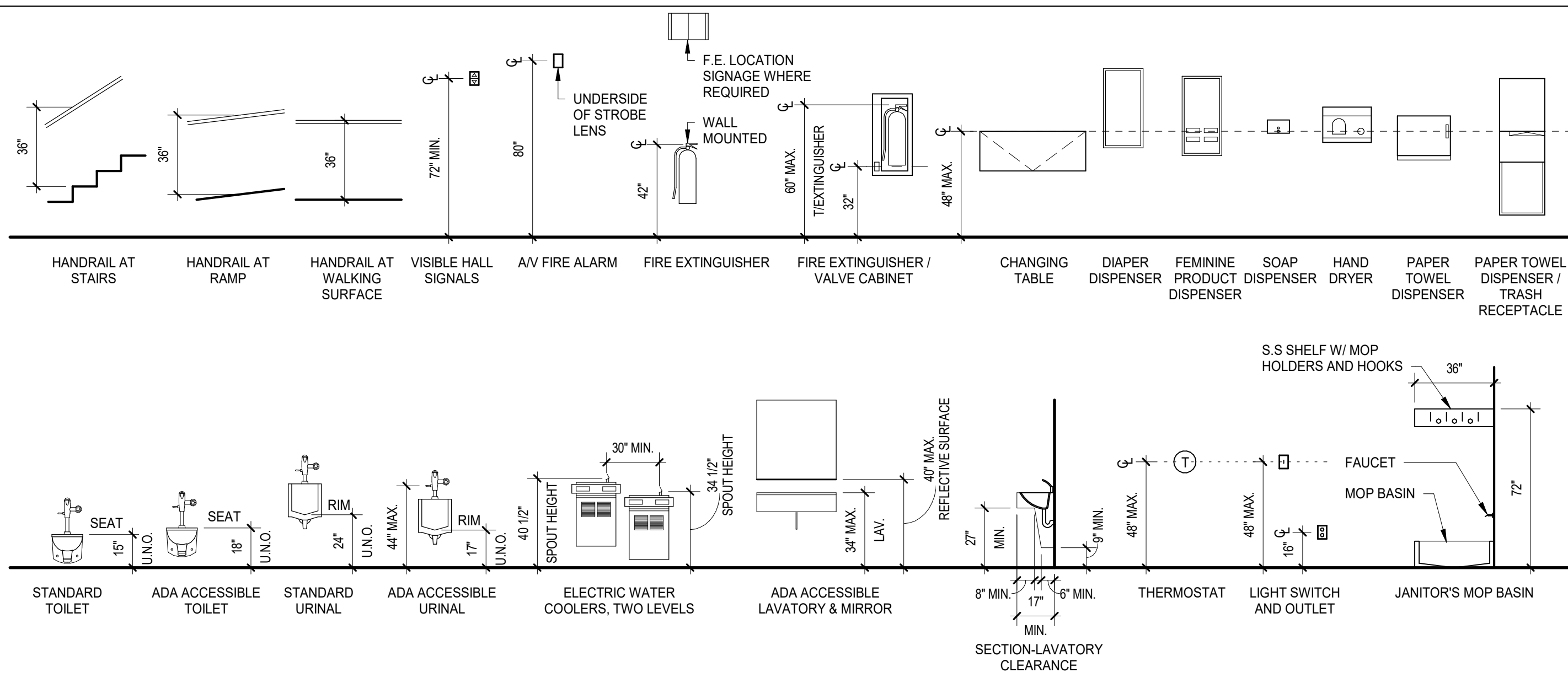

FIRESTOP SYSTEM MATRIX

DESCRIPTION	CONCRETE FLOOR OR BLOCK WALLS	GYPSON WALLS	GYPSON SHAFT WALLS
BLANK OPENING	CAJ-0090 FA-0014	WL-0012 WL-0040	
METAL PIPE	CAJ-1226 FA-1016	WL-1054 WL-1297	WL-1205 WL-1380
PLASTIC PIPE	CAJ-2109 FA-2054	WL-2078 WL-2128	
INSULATED PLASTIC PIPE	CAJ-5320	WL-5225	
CABLE BUNDLE	CAJ-3095 FA-3007	WL-3065 WL-3334 WL-3384	WL-3161
CABLE TRAYS	CAJ-4071 CAJ-4083	WL-4011	
METAL PIPE WITH GLASS FIBER OR POLYISO INSUL.	FA-5032 CAJ-5091 FA-5017	WL-5029 WL-5257	WL-5244
METAL PIPE WITH AB/PVC INSUL.	CAJ-5090 FA-5032 FA-5015	WL-5028 WL-5257	WL-5143
MISC. ELECTRICAL/ BUSWAY	CAJ-8017 CAJ-8042	WL-6019	
SHEET METAL DUCT/ RECTANGULAR	CAJ-7051	WL-7040 WL-7155 WL-7059	
SHEET METAL DUCT/ ROUND	CAJ-7084	WL-7042 WL-7153	WL-7068
MULTIPLE PENETRATIONS	CAJ-8143 FA-8012 FA-5032	WL-8065 WL-8079 WL-8071	WL-8098

ABBREVIATIONS

ACCESS. ACI.	ACCESSIBLE AMERICAN CONCRETE INSTITUTE	MAS. MFR./MAN UF./MANF.	MASONRY MANUFACTURER
ACOUST. ACT ADA	ACOUSTICAL ACoustical CEILING TILE AMERICANS WITH DISABILITIES ACT	MIN.	MEDIUM DENSITY FIBERBOARD MILLIMETERS
A.F.F. ALUM./AL. APPROX. ARCH.	ABOVE FINISHED FLOOR ALTERNATE ALUMINUM APPROXIMATE ARCHITECTURAL AMERICAN SOCIETY FOR TESTING AND MATERIALS	MISC. MHO M.O. MTL. NEG.	MISCELLANEOUS MAGNETIC HOLD OPEN MASONRY OPENING METALS NOT IN CONTRACT NUMBER
@ AV BLDG. BM B/O BRK. CAB CC C CMU	AT ALIQUO VISUAL BOARD BUILDING BEAM BOTTOM OF BREAK CABINET CENTER TO CENTER CENTERLINE CONTROL JOINT CONCRETE MASONRY UNITS	PL./P LAM. PLY. PP. R. PSF. PSI. P/PTD P.T. RAD. RCP RD. RESTRM. RM. R.O. RTU. SAFB	NOT TO SCALE ON CENTER OUTSIDE DIAMETER OVERFLOW ROOF DRAIN PIPE BOLLARD PERSON PLATE PLASTIC LAMINATE PLYWOOD DOOR ACTUATOR PUSH PLATE POUNDS PER SQUARE FEET POUNDS PER SQUARE INCH (PAINTED) PRESSURE TREATED RADIUS REFLECTED CEILING PLAN ROOF DRAIN RESTROOM ROOM ROUGH OPENING ROOF TOP UNIT SOUND ATTENUATION FIBER BATT INSULATION SEALED CONCRETE SCHEDULE
CONC. CONT. CORR. CPT. CR. CT. DIA. DIMS. DN. DR. DS. DWGS. EA. EIFS	CONCRETE CONTINUOUS CONTRACTOR CORRIDOR CARPET ACCESS CARD READER CERAMIC TILE DEMOLITION DIAMETER DIMENSIONS DOWN DOOR DOWN SPOUT DRAWINGS EACH EXTERIOR INSULATED FINISH SYSTEM ELEVATION ELECTRICAL ELEV. E.J. EQ. EQUIP. EWC EXP EXT. EXIST. ETR FD FF FIN. FL./FLR. FOUND. FT. FTG. GA. GALV. GWB/ GYP. BD.	SC. SCHD./SC HED. SD SF SFGT. SHT. SIM. SJ. S.M. SPA. SPEC. ST. STC STB. STR. STL. STS. STL/SS STOR. STRUCT. SV SYN T/ T/FG. TPNT TYP UNO. UNOOF DECK USGS. VB VCT. VERT. V.I.F. VWC. WC WD WOMENS W/ W/O WWF.	SHEMATIC DESIGN SQUARE FEET STRUCTURAL GLAZED FACING TILE SHEET SIMILAR STEEL JOINT INSTITUTE SHEET METAL SPACES SPECIFICATIONS STONE TILE SOUND TRANSMISSION COEFFICIENT STONE TILE BASE STEEL STEEL ANGLE STAINLESS STEEL STORAGE STRUCTURAL SHEET VINYL SYNTHETIC TOP OF TOP OF FOOTING TEXTURED PAINT TYPICAL UNLESS NOTED OTHERWISE UNDERSIDE OF ROOF DECK UNITED STATES GEOLOGICAL SURVEY VINYL BASE VINYL COMPOSITION TILE VERTICAL VERIFY IN FIELD VINYL WALL COVERING WATER CLOSET WOOD WOMENS WITH WITHOUT WELDED WIRE FABRIC

GENERAL NOTES

- WORK, MATERIALS AND METHODS SHALL BE IN CONFORMANCE WITH THE CODES, ORDINANCES AND REGULATIONS OF GOVERNMENTAL AGENCIES HAVING JURISDICTION AT THE PROJECT LOCATION.
- UNLESS OTHERWISE INDICATED IN THE CONSTRUCTION DOCUMENTS AS BEING NOT IN CONTRACT (N.I.C.) OR EXISTING, ITEMS, MATERIALS AND INSTALLATION OF SAME ARE PART OF THE CONTRACT AS DEFINED BY THE CONSTRUCTION DOCUMENTS. THE CONTRACTORS SHALL PROVIDE AND INSTALL ACCESSORIES, COMPONENTS AND ASSEMBLIES REQUIRED FOR THE WORK DEPICTED OR SPECIFIED.
- EACH CONTRACTOR SHALL BE RESPONSIBLE FOR VERIFYING DIMENSIONS AND EXISTING CONDITIONS BEFORE COMMENCING WORK. REPORT DISCREPANCIES AND/OR POTENTIAL PROBLEMS PRIOR TO PROCEEDING WITH AFFECTED WORK.
- FIRE-RATED ASSEMBLIES SHALL BE INSTALLED, LABELED, AND INSPECTED IN ACCORDANCE WITH THE APPLICABLE CODES. THIS INCLUDES FIRE DAMPERS OR FIRE DOORS PROVIDED WHERE AIR DUCTS OR OPENINGS PENETRATE FIRE RATED SURFACES. PENETRATIONS OF RATED FIRE RESISTIVE CONSTRUCTION SHALL BE PROTECTED WITH APPROVED FIRE ASSEMBLIES.
- PENETRATIONS THROUGH SURFACE SHALL BE SEALED WITH SEALANT MATERIAL PER SPECIFICATIONS. FOR PLUMBING, FIRE SPRINKLER AND ELECTRICAL SYSTEMS.
- IN THE EVENT OF DISCREPANCIES BETWEEN DRAWINGS AND/OR SPECIFICATIONS, THE MORE COSTLY OR MORE RESTRICTIVE CONDITIONS SHALL BE DEEMED THE CONTRACT REQUIREMENT UNLESS OTHERWISE STATED IN WRITING.
- PROVIDE GALVANIC PROTECTION BETWEEN DISSIMILAR MATERIALS, WHERE REQUIRED.
- KEEP PIPING AS CLOSE TO WALLS AS POSSIBLE UNLESS NOTED OTHERWISE.
- NO CONTRACTORS SHALL CLOSE OR OBSTRUCT STREETS, DOCKS, ALLEYS OR WALKS. NO MATERIALS ARE TO BE PLACED OR STORED IN STREETS, ALLEYS OR WALKS. DEBRIS IS TO BE REMOVED COMPLETELY FROM THE PREMISES.
- CONTRACTORS SHALL PROVIDE AND ARE SOLELY RESPONSIBLE AND LIABLE FOR PUBLIC AND EMPLOYEE PROTECTION AS NECESSARY AND AS REQUIRED BY THE CODES, INCLUDING EXTERIOR, INTERIOR PEDESTRIAN AND TRAFFIC BARRIERS. EXISTING EXIT CORRIDORS, PATHS OF EXITS, STAIRWAYS, OR EXIT SIGNAGE, MUST HAVE A CLEAR MEANS OF EGRESS DURING PHASES OF CONSTRUCTION.
- CONTRACTORS WISHING TO WORK IN THE BUILDING OR ON THE BUILDING PROPERTY SHALL BE REQUIRED TO PRESENT THE PROPER CERTIFICATES OF INSURANCE. CONTRACTORS ARE REQUIRED TO BE LICENSED WITH THE LOCAL JURISDICTION. LICENSES AND BONDING ARE TO BE INCLUDED IN THE BID PER THE REQUIREMENTS IN THE SPECIFICATIONS.
- DIMENSIONS NOTED ON THE ARCHITECTURAL FLOOR PLAN REGARDING DETAILS AND PARTITION THICKNESSES ARE NOMINAL DIMENSIONS. REFER TO A8 SERIES FOR THE EXACT DIMENSION.

GRAPHIC SYMBOLS

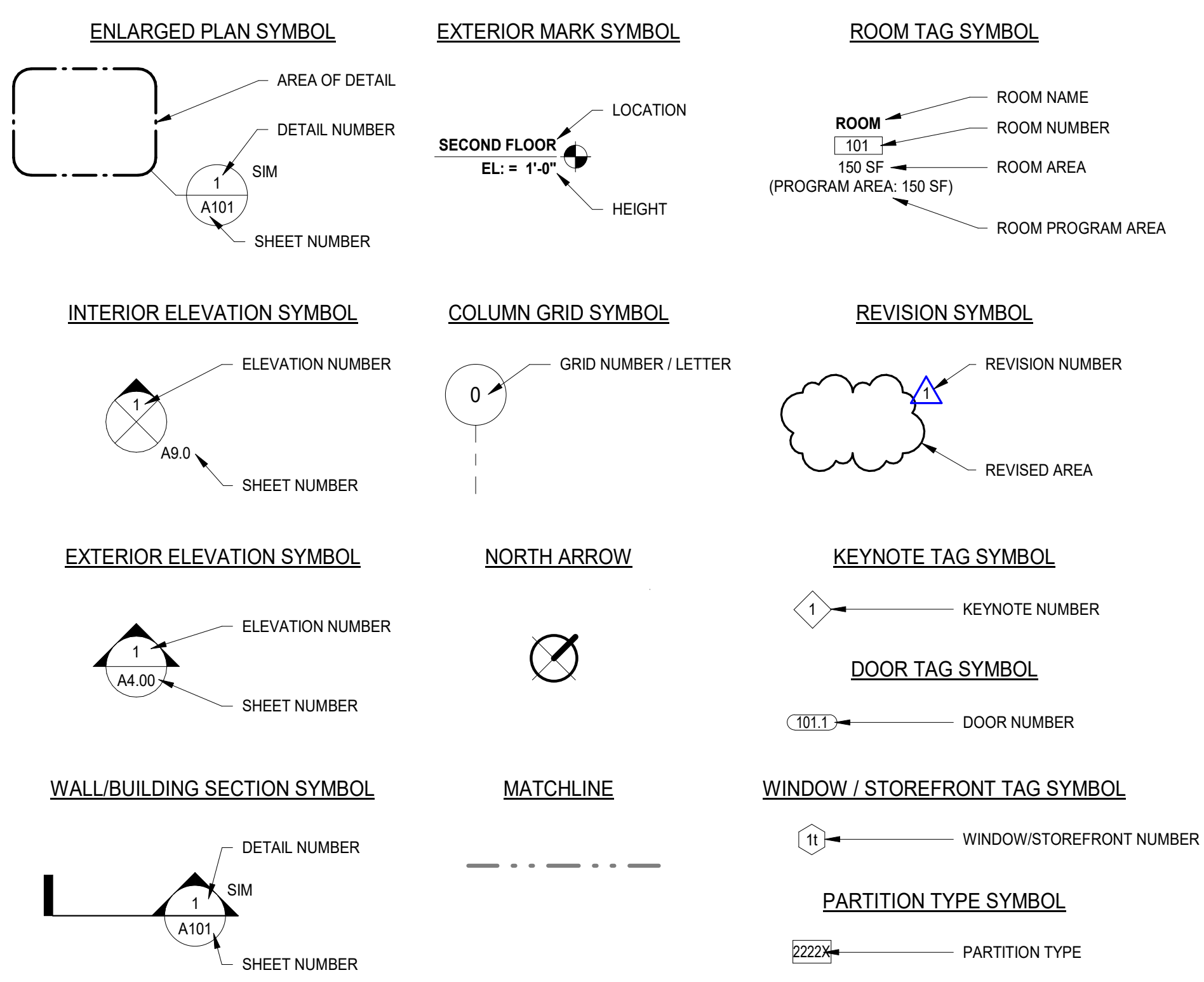

MATERIAL LEGEND

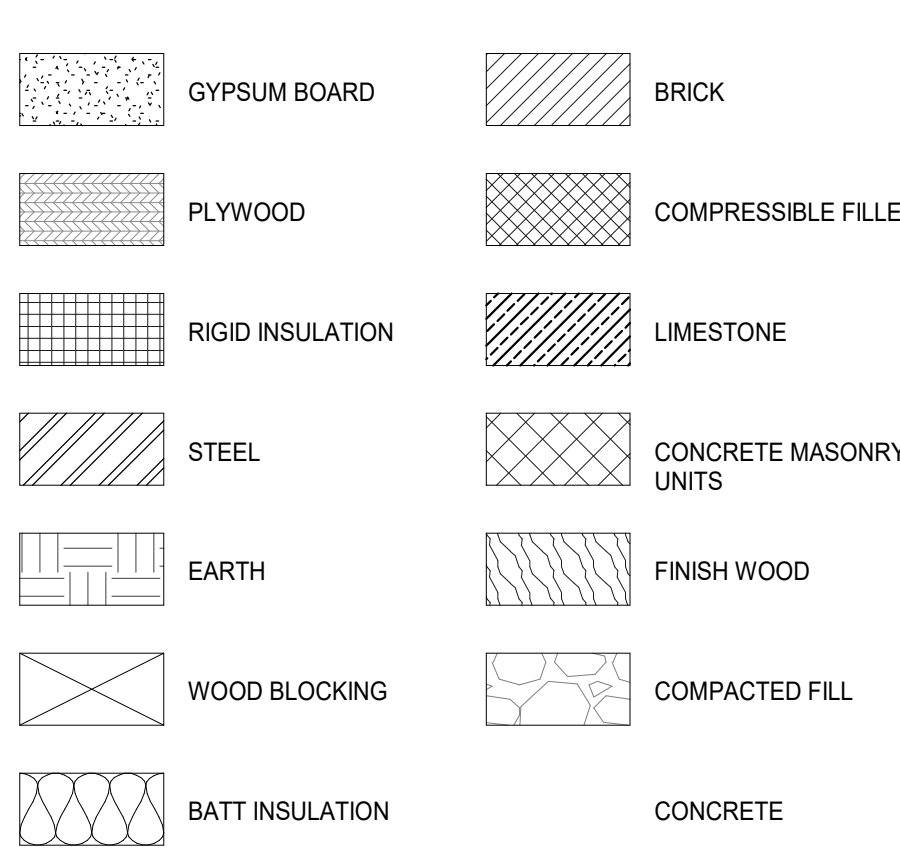

TOP OF WALL JOINTS

DESCRIPTION	CONCRETE BLOCK WALLS	GYPSON WALLS	EXTERIOR WALL
PERP. TO METAL DECK	HWD-0042 HWD-1066/1067 HWD-0045	HWD-1037 HWD-0081	
PARALLEL TO METAL DECK	HWD-0049 HWD-1067 HWD-0184 HWD-0539	HWD-0181 HWD-0081	
PARALLEL TO STEEL BEAM	HWD-0259		
FLAT CONCRETE	HWD-1068 HWD-0208	HWD-1058 HWD-0268	
CUT TO PROFILE	HW-0324		
SHAFT WALL PARALLEL TO DECK	HWD-0570		
SHAFT WALL PERP. TO DECK	HWD-0569		
SHAFT WALL TO FLAT CONCRETE	HWD-0342 HWD-0572		

FURNISHED AND INSTALLED MATRIX.

D58 Equipment Matrix Henry Puffer

TOILET ROOM ACCESSORIES	FURNISHED BY	INSTALLED BY
PAPER TOWEL HOLDER	TOILET ROOMS	OWNER
SOAP DISPENSERS	TOILET ROOMS	OWNER
TOILET PAPER HOLDERS	TOILET ROOMS	OWNER
ALL OTHER ACCESSORIES	TOILET ROOMS	CONTRACTOR



Wight

Wight & Company
wightco.com
2500 North Frontage Road
Darien, IL 60561
P 630.969.7700
F 630.969.7979

NOT FOR CONSTRUCTION

TYPICAL DOOR LOCATION

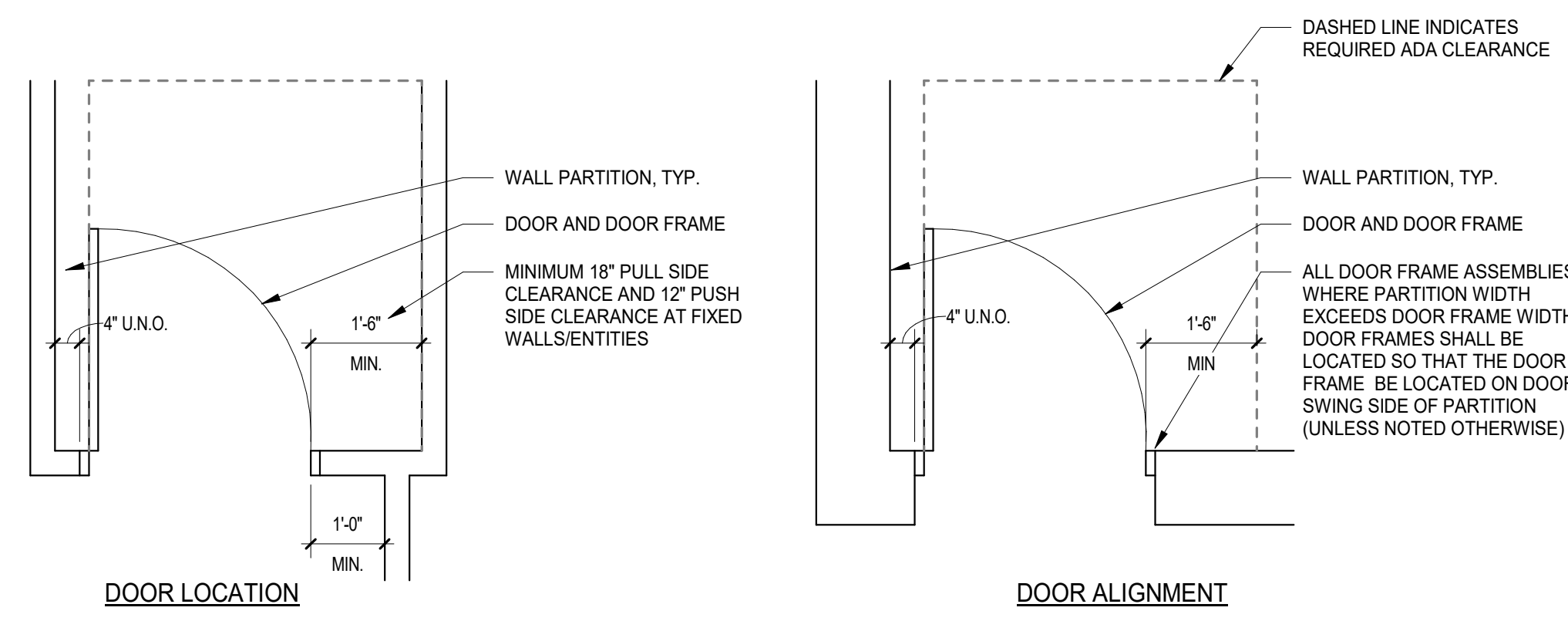

ADA ACCESSIBLE TOILET PLAN & ELEVATIONS

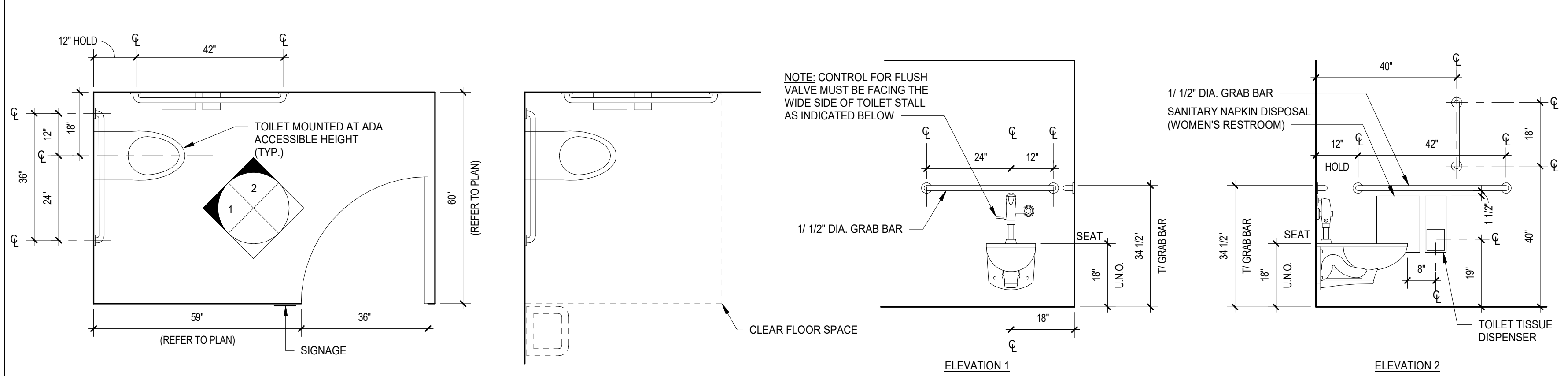

12/12/2023 10:15:32 AM Autodesk Docs/70588 EHS Phase 1/220281_Highland_ARCH_2023.rvt Wight & Co. © Copyright 2016 All rights reserved. No part of these documents may be reproduced, stored, or transmitted in any form or by any means, electronic, mechanical, photocopying, recording or otherwise, without the prior written consent of Wight & Co.

E-RATE RFP 12.18.2023
REV DESCRIPTION DATE

Highland Elementary School - D58 Referendum Improvements

3935 Highland Ave
Downers Grove, IL 60515

GENERAL INFORMATION, SYMBOLS, NOTES & ABBREVIATIONS

Project Number:
220281
Drawn By:
Drawn By
Sheet:

GO.02

COMMUNICATIONS & LOW VOLTAGE CONDUIT REQUIREMENTS:

ALL CONDUIT RUNS SHALL BE 3/4" EMT, UNLESS NOTED OTHERWISE.

ALL BOXES SHALL BE A MINIMUM OF 4-11/16" x 4-11/16" x 2-1/8" DEEP BOX WITH A SINGLE GANG TRIM RING MOUNTED FLUSH TO THE WALL SURFACE, UNLESS NOTED OTHERWISE.

ALL MOUNTING HEIGHTS ARE TO THE CENTERLINE OF THE BACKBOX UNLESS NOTED OTHERWISE.

ALL CONDUIT SHALL BE ROUTED ABOVE CEILINGS, BELOW FLOORS, OR STUBBED UP WITHIN WALLS; NO CONDUIT SHALL BE EXPOSED UNLESS APPROVED BY THE ARCHITECT.

ALL CONDUITS IN WALLS SHALL STUB UP AT LEAST 6-INCHES ABOVE THE FINISHED CEILING. ALL STUBS SHALL BE REAMED AND BUSHED AT BOTH ENDS.

ALL CONDUIT PENETRATIONS THROUGH FIRE-RATED PARTITIONS SHALL BE SEALED AS REQUIRED BY CODE. ALL BACKBOXES MOUNTED WITHIN FIRE-RATED PARTITIONS SHALL MEET THE FIRE RATING OF THE PARTITION AS REQUIRED BY CODE.

PROVIDE PULL STRINGS IN ALL CONDUIT RUNS LONGER THAN 10-FEET.

PROVIDE PULL BOXES EVERY 100 LINEAR FEET OR AFTER TWO SUCCESSIVE 90° BENDS.

ALL JUNCTION AND PULL BOXES SHALL BE FURNISHED WITH ACCOMPANYING BLANK COVER PLATE.

ALL BOXES IN EXTERIOR LOCATIONS SHALL BE WEATHERPROOF AND WATERPROOF.

INSTRUCTIONS SHOWN IN DIMENSION LINES, DETAILS, ELEVATIONS, AND PLANS (IN THIS ORDER) TAKE PRECEDENCE OVER INSTRUCTIONS SHOWN IN LEGENDS.

CONDUIT AND CABLE ROUTING SHOWN IS SCHEMATIC AND IS NOT INTENDED TO REPRESENT INSTALLATION PATHS OR DISTANCES. ACTUAL ROUTING AND BOX LOCATIONS SHALL BE FIELD-VERIFIED FOR FEASIBILITY AND COORDINATED WITH OTHER DISCIPLINES BY THE INSTALLATION CONTRACTOR.

HORIZONTAL CONDUITS INTO EACH TECHNOLOGY AREA FROM THE EXTERIOR CEILING PLENUM ARE REQUIRED FOR CABLE ACCESS INTO THE ROOM FROM ALL LOCATIONS THROUGHOUT THE SPACE. THE ENDS OF THE CONDUITS SHALL BE REAMED AND BUSHED, AND EXTEND A MINIMUM OF 2-INCHES INTO THE ROOM.

CABLE O.D. (")	CONDUIT TRADE SIZE AND MAXIMUM QUANTITIES OF CABLES OF THAT O.D.						
	3/4"	1"	1-1/4"	1-1/2"	2"	3"	4"
0.16	10	19	33	46	75	200	333
0.18	8	13	23	32	52	139	231
0.20	6	11	19	25	42	112	187
0.25	4	6	12	16	27	71	120
0.27	3	6	10	14	22	60	102
0.30	2	4	8	10	18	48	82
0.33	1	4	6	8	14	40	68
0.35	1	3	6	8	12	36	60
0.38	1	2	5	7	10	30	50
0.40	1	2	4	6	10	28	46
0.45	1	1	3	5	8	22	38
0.50	1	1	2	4	6	16	30
0.55	1	1	1	3	5	14	24
0.60	N/A	1	1	2	4	12	20
0.67	N/A	1	1	1	3	10	16
0.70	N/A	1	1	1	3	8	14
0.75	N/A	N/A	1	1	2	7	12

NUMBER AND SIZE OF CONDUITS	PULL BOX SIZE (W x L x H IN INCHES)	FOR EACH ADDITIONAL CONDUIT ENTERING THE PULL BOX, INCREASE THE WIDTH
ONE 1-INCH	4 X 16 X 3	2 INCHES
ONE 1-1/4-INCH	6 X 20 X 3	3 INCHES
ONE 1-1/2-INCH	8 X 27 X 4	4 INCHES
ONE 2-INCH	8 X 36 X 4	5 INCHES
ONE 4-INCH	15 X 60 X 8	8 INCHES

TECHNOLOGY DRAWING INDEX - E-RATE RFP

- T0.0 - LEGEND AND GENERAL NOTES
- T1.0 - TECHNOLOGY PLAN - AREA A
- T1.1 - TECHNOLOGY PLAN - AREA B
- T1.2 - TECHNOLOGY PLAN - AREA C
- T1.3 - MDF PLAN

TELECOMMUNICATIONS GROUNDING NOTES:

1. REFER TO E-SERIES DRAWINGS FOR PANEL SCHEDULING INFORMATION AND GROUNDING ELECTRODE SYSTEM DATA.
2. A SINGLE GROUND SOURCE SHALL BE PROVIDED FOR GROUNDING ALL RACKS, TRAYS AND METAL FRAMES IN THE MAIN DISTRIBUTION FRAME. A TELECOMMUNICATIONS MAIN GROUNDING BUSBAR (TMGB) SHALL BE PROVIDED AND INSTALLED ON THE MAIN CROSS-CONNECT WALL AT A HEIGHT OF 8-FEET AFF. THE TMGB SHALL CONSIST AT A MINIMUM OF A PREDRILLED COPPER BUSBAR WITH HOLES FOR USE WITH STANDARD-SIZED LUGS, AND HAVE MINIMUM DIMENSIONS OF 1/4-INCH THICK BY 4-INCHES WIDE WITH A MINIMUM OF FORTY-EIGHT (48) CONNECTION POINTS. THE TMGB SHALL BE DIRECTLY BONDED TO THE ELECTRICAL SERVICE GROUND AND TO THE BUILDING STEEL.
3. A TELECOMMUNICATIONS GROUNDING BUSBAR (TGB) SHALL BE INSTALLED IN ANY/ALL TELECOM ROOMS. THE TGB SHALL BE MOUNTED ON THE HORIZONTAL CROSS-CONNECT WALL AT A HEIGHT OF 8-FEET AFF. THE TGB SHALL CONSIST OF A PREDRILLED COPPER BUSBAR WITH HOLES FOR USE WITH STANDARD-SIZED LUGS, AND HAVE MINIMUM DIMENSIONS OF 1/4-INCH THICK BY 2-INCHES WIDE WITH A MINIMUM OF TWELVE (12) CONNECTION POINTS.
4. A GROUND CABLE FROM THE TMGB TO EACH TGB SHALL BE INSTALLED TO CREATE A FORMAL TELECOMMUNICATIONS BONDING BACKBONE (TBB). THE TBB MAY NOT BE DAISY-CHAINED, BUT CAN BE TAPPED-OFF USING A SHORT BONDING CONDUCTOR. BARE COPPER CABLING IS ACCEPTABLE. THE TBB SHALL BE SIZED BASED ON THE LENGTH OF THE CABLE RUN.
5. THE CONTRACTOR SHALL PROVIDE AND INSTALL A MINIMUM #6 AWG GROUND WIRE FROM EACH OPEN RELAY RACK AND CABLE TRAY TO THE MAIN TELECOMMUNICATIONS GROUNDING BUSBAR OR TELECOMMUNICATIONS GROUNDING BUSBAR.
6. ANY PENETRATION THROUGH A FIRE-RATED WALL SHALL BE PROPERLY FIRE-STOPPED BY THE CONTRACTOR WITH THE APPROPRIATE FIRE-STOP MATERIAL PER APPLICABLE BUILDING AND ELECTRICAL CODES.
7. THE CONTRACTOR SHALL COORDINATE GROUND CABLE INSTALLATION WITH THE ARCHITECTS, MEP ENGINEERS AND THE OTHER TRADES ON THE PROJECT.
8. THE CONTRACTOR SHALL ASSUME RESPONSIBILITY FOR ANY DAMAGE TO ANY COMPONENT OF THE TELECOMMUNICATIONS GROUNDING SYSTEM DURING INSTALLATION.
9. THE CONTRACTOR SHALL VERIFY THAT THE SIZE OF THE TMGB AND THE TGB ARE ADEQUATE TO SUPPORT THE TELECOMMUNICATIONS GROUNDING REQUIREMENTS FOR THE PROJECT.

ANSI/TIA-607-B CONDUCTOR SIZES	
LENGTH IN FEET	CONDUCTOR SIZE (AWG)
LESS THAN 13	6
14 - 20	4
21 - 26	3
27 - 33	2
34 - 41	1
42 - 52	1/0
53 - 66	2/0
67 - 84	3/0
85 - 105	4/0
106 - 125	250 KCMIL
126 - 150	300 KCMIL
151 - 175	350 KCMIL
176 - 250	500 KCMIL
251 - 300	600 KCMIL
GREATER THAN 301	750 KCMIL

ABBREVIATIONS USED IN THESE DRAWINGS:

- AVC = AUDIOVISUAL CABLING CONTRACTOR
- CIC = CABLING INSTALLATION CONTRACTOR
- EC = ELECTRICAL INSTALLATION CONTRACTOR
- PIC = PAGING INSTALLATION CONTRACTOR
- SIC = SECURITY INSTALLATION CONTRACTOR

- X** MOUNTING INFORMATION, WHERE X =
- A ABOVE CEILING
 - D TO THE DESK
 - F FLUSH-MOUNTED
 - H HIDDEN UNDER WORKSURFACE
 - M TO THE MULLION
 - R TO THE RACK ITSELF
 - S PLACED ON THE WORKSURFACE

- AV** MOUNTING INFORMATION, WHERE X =
- A ABOVE CEILING
 - D TO THE DESK
 - F FLUSH-MOUNTED
 - H HIDDEN UNDER WORKSURFACE
 - M TO THE MULLION
 - P TO THE PODIUM
 - R TO THE RACK ITSELF
 - S PLACED ON THE WORKSURFACE
 - TX TRANSMITTER
 - RX RECEIVER

NOTE: COORDINATE WITH THE ARCHITECT AND GENERAL CONTRACTOR FOR EXACT MOUNTING LOCATIONS PRIOR TO INSTALLATION OF ANY COMPONENTS.

THIS DRAWING SERIES IS INTENDED TO SHOW QUANTITIES. REFER TO A-SERIES AND E-SERIES DRAWINGS FOR EXACT LOCATIONS, HEIGHTS, AND PLACEMENT.

NOTE: THIS DRAWING SET INCORPORATES THREE-PART SPECIFICATIONS FOR INTERPRETATION; THEREFORE, THESE SPECIFICATIONS AND DRAWINGS SHALL BE TREATED AS A SINGLE ISSUANCE. IF EITHER COMPONENT IS NOT UTILIZED FOR BID, REVIEW, OR CONSTRUCTION, THEN CRITICAL INFORMATION IS MISSING THAT MAY AFFECT SCHEDULE AND PRICING. INSTALLATION CONTRACTORS SHALL TRANSMIT, DOWNLOAD, AND INCORPORATE THESE SPECIFICATIONS ALONG WITH THESE DRAWINGS.

NOTE: BASE BID WORK IS AS FOLLOWS:

1. BASE BID WORK SHALL INCLUDE ALL CABLING LOCATIONS IN THE HIGHLIGHTED AREAS
2. ALL CABLING LOCATIONS FOR PAGING SYSTEM, CAMERA, AND WALL DATA LOCATIONS THROUGHOUT THE ENTIRE SCHOOL

NOTE: ALTERNATE BID WORK IS AS FOLLOWS:

1. WIRELESS ACCESS POINT LOCATIONS THROUGHOUT THE ENTIRE SCHOOL NOT IN BASE BID AREAS
2. PROJECTOR LOCATIONS THROUGHOUT THE ENTIRE SCHOOL NOT IN BASE BID AREAS

COMMUNICATIONS LEGEND:

- 2** TWO (2) CABLE AND TWO (2) JACK LOCATION. CIC TO FURNISH AND INSTALL TWO (2) CATEGORY 6 CABLES AND TWO (2) CATEGORY 6 8P8C (RJ45) JACKS AT THIS LOCATION. REFER TO THE SPECIFICATION FOR CABLE AND JACK REQUIREMENTS. MOUNT AT +15" AFF. O.C. UNO. CIC TO COORDINATE FACEPLATE FINISH AND HEIGHT WITH ARCHITECTS.
- E** EXISTING DATA LOCATION. CIC TO FURNISH AND INSTALL ONE (1) CATEGORY 6 CABLE AND ONE (1) CATEGORY 6 8P8C (RJ45) JACK AT THIS LOCATION. REFER TO THE SPECIFICATION FOR CABLE AND JACK REQUIREMENTS. CIC TO COORDINATE FACEPLATE FINISH AND HEIGHT WITH ARCHITECTS. PROVIDE FACEPLATE BLANK FOR ANY UNUSED OPENINGS IN THE FACEPLATE.
- D** EXISTING DATA LOCATION TO BE REMOVED. CICTO FURNISH AND INSTALL A BLANK FACEPLATE AT THIS LOCATION TO COVER THE OPENING. CIC TO COORDINATE FACEPLATE FINISH AND HEIGHT WITH ARCHITECTS.
- WAP** CEILING DATA LOCATION CONSISTING OF TWO (2) CATEGORY 6A 8P8C (RJ45) JACKS AND TWO (2) CATEGORY 6 CABLES TO SUPPORT CUSTOMER PROVIDED AND CIC INSTALLED WIRELESS ACCESS POINTS. CIC TO FURNISH AND INSTALL TWO (2) CATEGORY 6A CABLES AND TWO (2) CATEGORY 6A 8P8C (RJ45) JACKS WITH A 25-FOOT SERVICE LOOP AT THIS LOCATION. CIC TO FURNISH AND INSTALL TWO (2) CATEGORY 6A CABLES AND TWO (2) CATEGORY 6A 8P8C (RJ45) MODULAR PLUGS AT END OF THE 25-FOOT SERVICE LOOP COIL. REFER TO THE SPECIFICATION FOR CABLE AND JACK REQUIREMENTS.
- C** CEILING DATA LOCATION CONSISTING OF ONE (1) CATEGORY 6 CABLE TO SUPPORT SIC FURNISHED AND INSTALLED SURVEILLANCE CAMERA. CIC TO FURNISH AND INSTALL ONE (1) CATEGORY 6 CABLE AND ONE (1) CATEGORY 6 8P8C (RJ45) MODULAR PLUG WITH A 3-FOOT SERVICE LOOP AT THIS LOCATION. REFER TO THE SPECIFICATION FOR CABLE REQUIREMENTS.
- C** WALL MOUNTED DATA LOCATION CONSISTING OF ONE (1) CATEGORY 6 CABLE TO SUPPORT SIC FURNISHED AND INSTALLED SURVEILLANCE CAMERA. CIC TO FURNISH AND INSTALL ONE (1) CATEGORY 6 CABLE AND ONE (1) CATEGORY 6 8P8C (RJ45) MODULAR PLUG WITH A 3-FOOT SERVICE LOOP AT THIS LOCATION. REFER TO THE SPECIFICATION FOR CABLE REQUIREMENTS.
- PCL** CIC FURNISHED AND INSTALLED IP-BASED PAGING SPEAKER AND CLOCK. REFER TO THE SPECIFICATION FOR REQUIREMENTS. CIC TO COORDINATE SPEAKER/CLOCK FINISH AND HEIGHT WITH ARCHITECTS.
- CL** CIC FURNISHED AND INSTALLED IP-BASED PAGING DUAL SIDED CLOCK. REFER TO THE SPECIFICATION FOR REQUIREMENTS. CIC TO COORDINATE CLOCK FINISH AND HEIGHT WITH ARCHITECTS.
- PS** CIC FURNISHED AND INSTALLED IP-BASED CEILING MOUNTED PAGING SPEAKER. REFER TO THE SPECIFICATION FOR REQUIREMENTS. CIC TO COORDINATE SPEAKER FINISH AND HEIGHT WITH ARCHITECTS.
- OPS** CIC FURNISHED AND INSTALLED IP-BASED OUTDOOR PAGING SPEAKER. REFER TO THE SPECIFICATION FOR REQUIREMENTS. CIC TO COORDINATE SPEAKER FINISH AND HEIGHT WITH ARCHITECTS.
- ST** CIC FURNISHED AND INSTALLED IP-BASED OUTDOOR STROBE. REFER TO THE SPECIFICATION FOR REQUIREMENTS. CIC TO COORDINATE SPEAKER FINISH AND HEIGHT WITH ARCHITECTS.
- P** CEILING DATA LOCATION CONSISTING OF TWO (2) CATEGORY 6 8P8C (RJ45) JACKS AND TWO (2) CATEGORY 6 CABLES TO SUPPORT CUSTOMER PROVIDED AND INSTALLED PROJECTORS. CIC TO FURNISH AND INSTALL TWO (2) CATEGORY 6 CABLES AND TWO (2) CATEGORY 6 8P8C (RJ45) JACKS WITH A 25-FOOT SERVICE LOOP AT THIS LOCATION. CIC SHALL FURNISH AND INSTALL A PLENUM-RATED TWO-JACK RJ-45 (8P8C) HUBBELL ISB2WP (OR EQUIVALENT) MODULE AT END OF THE 25-FOOT SERVICE LOOP COIL. REFER TO THE SPECIFICATION FOR CABLE AND JACK REQUIREMENTS.
- PS** ONE (1) CABLE AND ONE (1) JACK LOCATION. CIC TO FURNISH AND INSTALL ONE (1) CATEGORY 6 CABLE AND ONE (1) CATEGORY 6 8P8C (RJ45) JACK AT THIS LOCATION TO SUPPORT IP-BASED PAGING SYSTEM SPEAKER AND CLOCK. REFER TO THE SPECIFICATION FOR CABLE AND JACK REQUIREMENTS. CIC TO COORDINATE FACEPLATE FINISH AND HEIGHT WITH ARCHITECTS.
- PS2** TWO (2) CABLE AND TWO (2) JACK LOCATION. CIC TO FURNISH AND INSTALL TWO (2) CATEGORY 6 CABLES AND TWO (2) CATEGORY 6 8P8C (RJ45) JACKS AT THIS LOCATION TO SUPPORT IP-BASED PAGING SYSTEM CLOCK. REFER TO THE SPECIFICATION FOR CABLE AND JACK REQUIREMENTS. CIC TO COORDINATE FACEPLATE FINISH AND HEIGHT WITH ARCHITECTS.
- WAP** TWO (2) CABLE AND TWO (2) JACK LOCATION TO SUPPORT CUSTOMER PROVIDED AND CIC INSTALLED WIRELESS ACCESS POINTS. CIC TO FURNISH AND INSTALL TWO (2) CATEGORY 6A CABLES AND TWO (2) CATEGORY 6A 8P8C (RJ45) JACKS AT THIS LOCATION. REFER TO THE SPECIFICATION FOR CABLE AND JACK REQUIREMENTS. CIC TO COORDINATE FACEPLATE FINISH AND HEIGHT WITH ARCHITECTS.
- 1** ONE (1) CABLE AND ONE (1) JACK LOCATION. CIC TO FURNISH AND INSTALL ONE (1) CATEGORY 6 CABLE AND ONE (1) CATEGORY 6 8P8C (RJ45) JACK AT THIS LOCATION. REFER TO THE SPECIFICATION FOR CABLE AND JACK REQUIREMENTS. MOUNT AT +15" AFF. O.C. UNO. CIC TO COORDINATE FACEPLATE FINISH AND HEIGHT WITH ARCHITECTS.

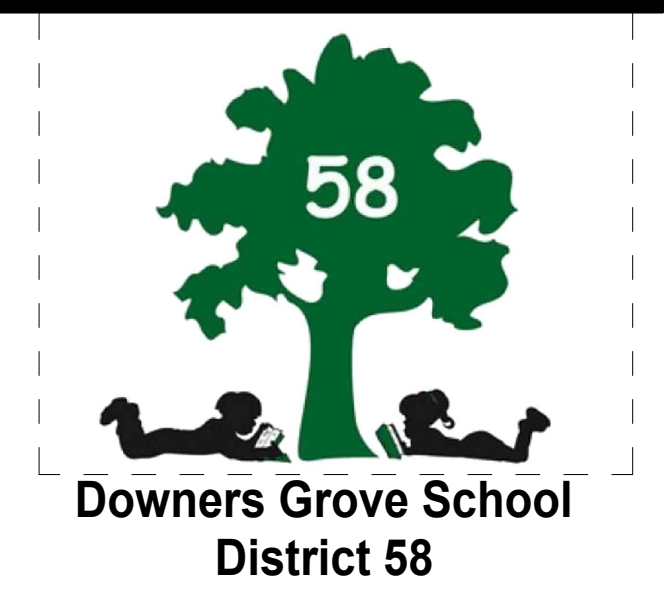

Wight & Company
wightco.com
2500 North Frontage Road
Darien, IL 60561
P 630.969.7000
F 630.969.7979

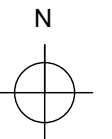
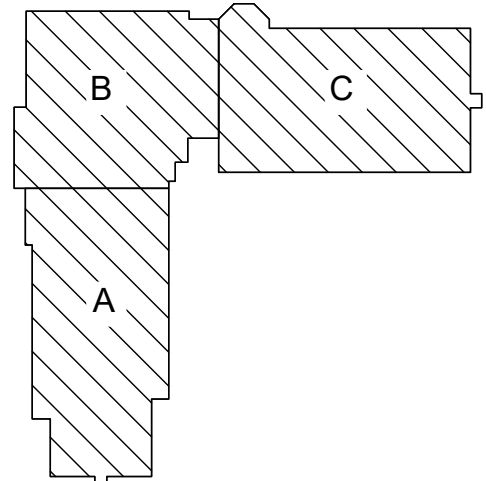

NOT FOR CONSTRUCTION

REV	E-RATE RFP DESCRIPTION	12/18/2023 DATE

HIGHLAND ELEMENTARY SCHOOL

3935 HIGHLAND AVE.
DOWNERS GROVE, IL 60515

LEGEND AND GENERAL NOTES

Project Number:
220281
Drawn By:
-
Sheet:

SENTINEL
2550 WARRENVILLE ROAD
DOWNERS GROVE, ILLINOIS 60515
630.769.4300
www.sentinel.com

Bicsi
REGISTERED COMMUNICATIONS CONTRACTOR
EXPIRES 12/31/23
Reg. No. 119887

T0.0

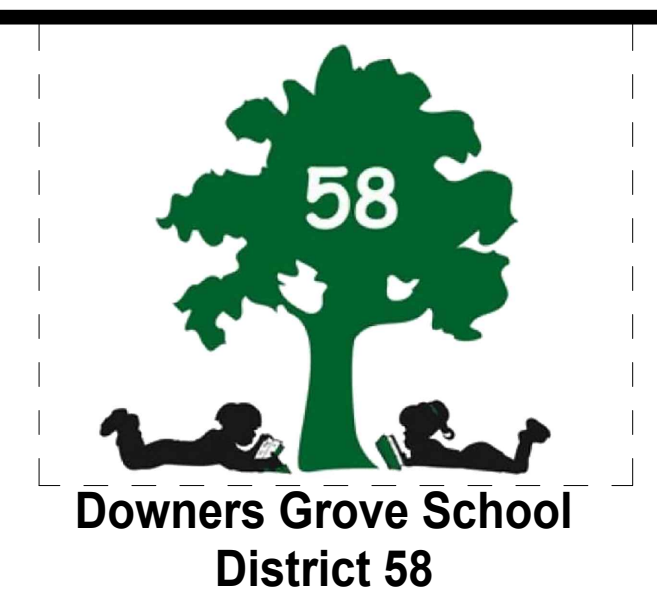
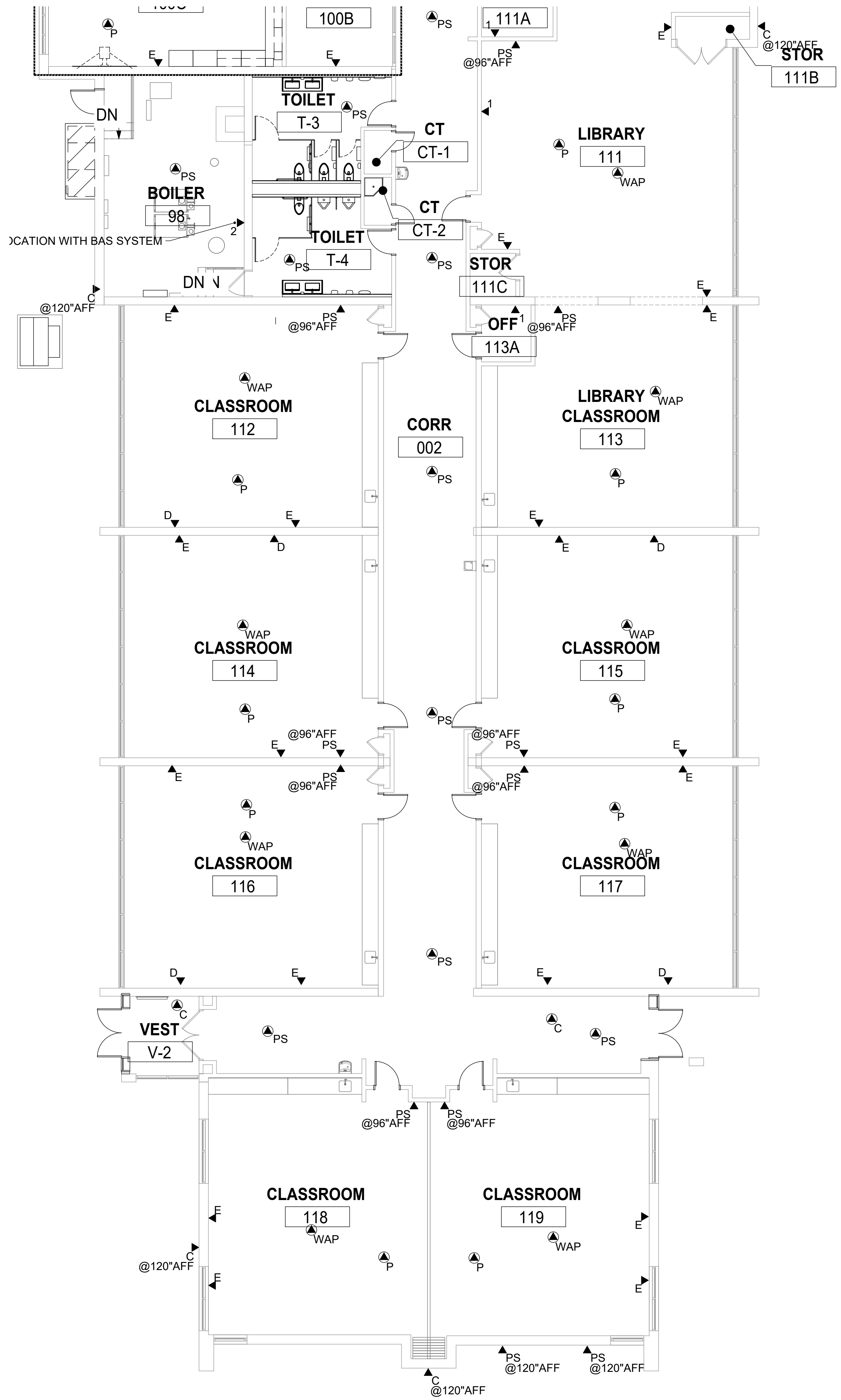

Wight

Wight & Company
 wightco.com
 2500 North Frontage Road
 Darien, IL 60561
 P 630.969.7000
 F 630.969.7979

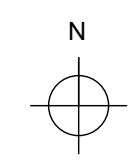
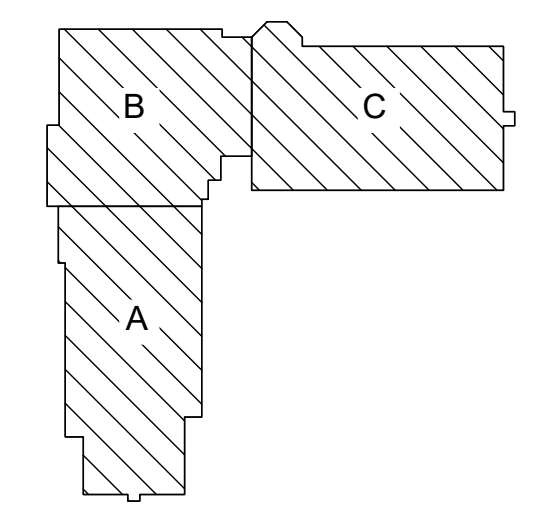

NOT FOR CONSTRUCTION

REV	E-RATE RFP DESCRIPTION	12/18/2023 DATE
-----	------------------------	-----------------

HIGHLAND ELEMENTARY SCHOOL

3935 HIGHLAND AVE.
 DOWNERS GROVE, IL 60515
TECHNOLOGY PLAN - AREA A



Project Number: 220281
 Drawn By: -
 Sheet:

T1.0



Downers Grove School
District 58

Wight

Wight & Company
wightco.com
2500 North Frontage Road
Darien, IL 60561
P 630.969.7000
F 630.969.7979

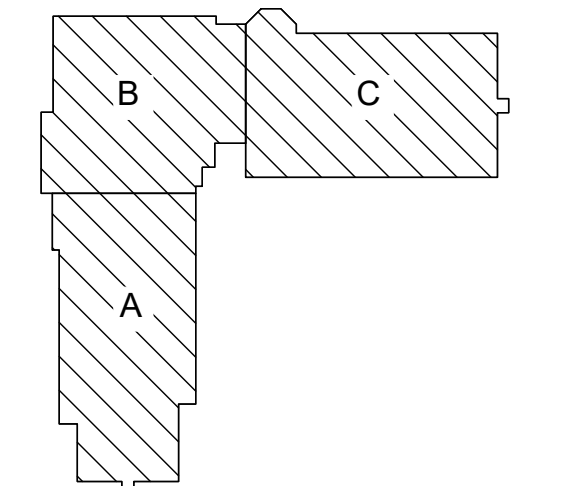

**NOT FOR
CONSTRUCTION**

REV	E-RATE RFP DESCRIPTION	12/18/2023 DATE
-----	------------------------	-----------------

HIGHLAND ELEMENTARY SCHOOL

3935 HIGHLAND AVE.
DOWNERS GROVE, IL 60515

TECHNOLOGY PLAN - AREA B

Project Number:
220281
Drawn By:
-
Sheet:



T1.1

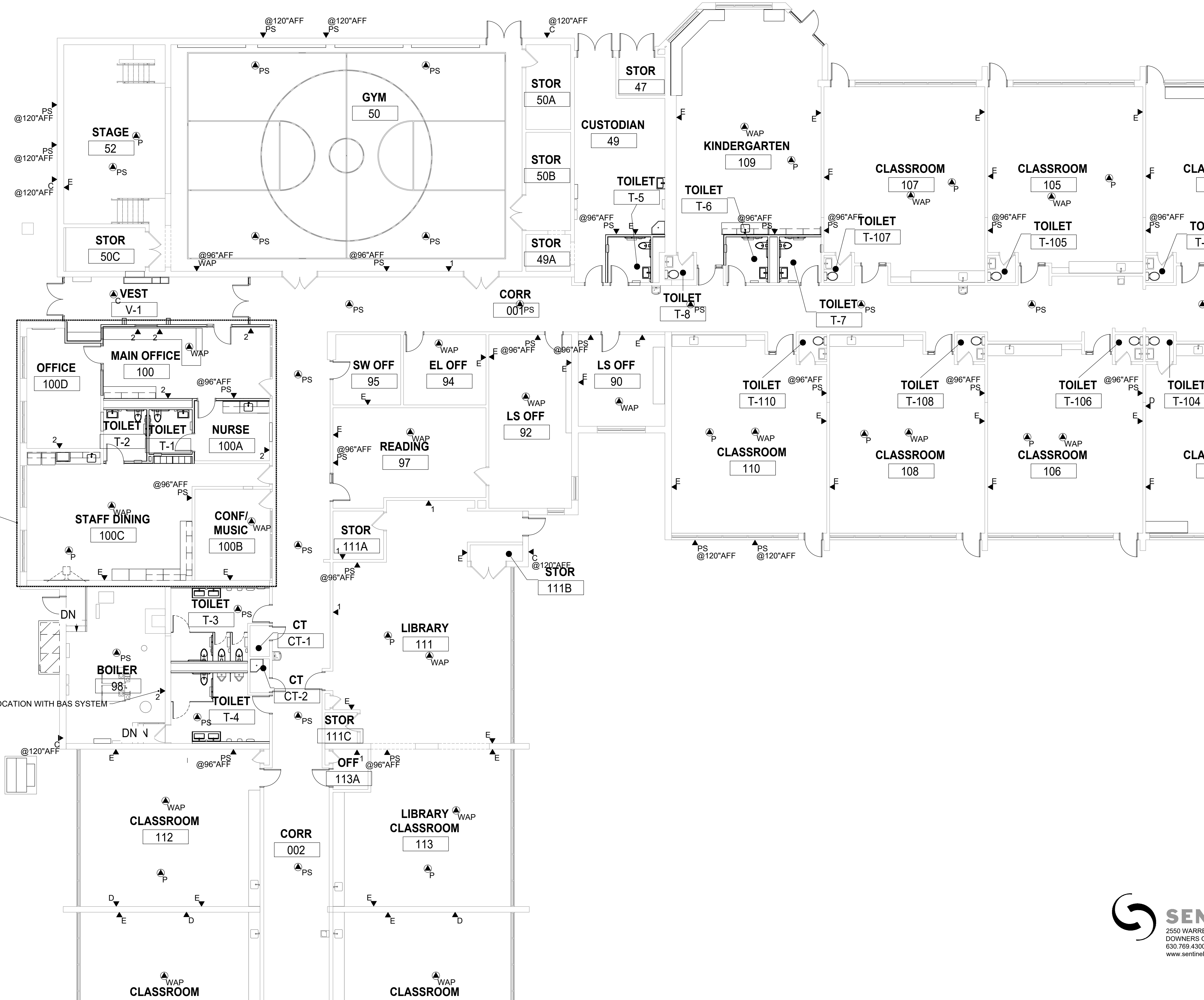

AREA OF BASE BID WORK

COORDINATE LOCATION WITH BAS SYSTEM

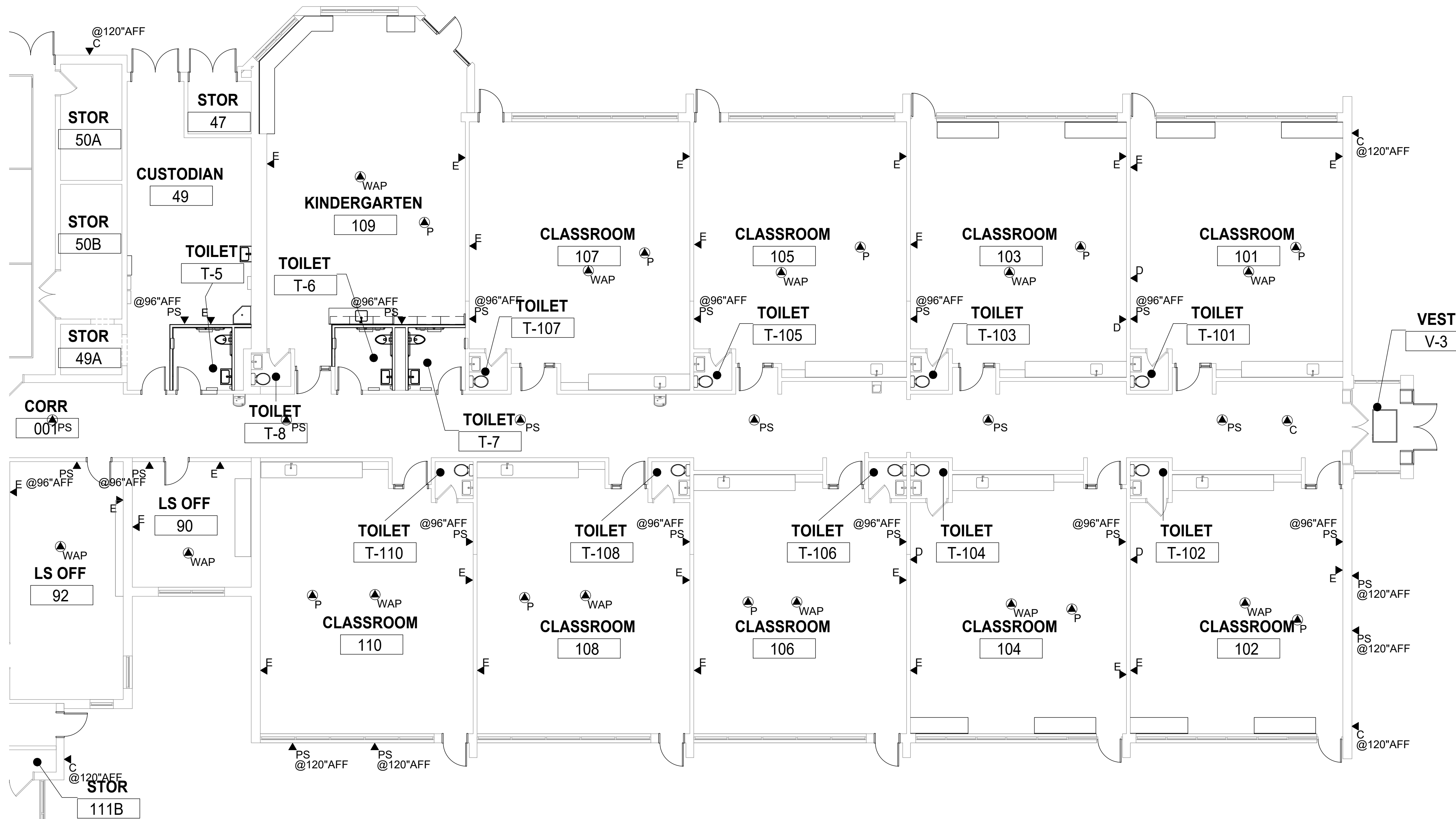

1 TECHNOLOGY PLAN
PLAN VIEW

NORTH
1/8" = 1' - 0"

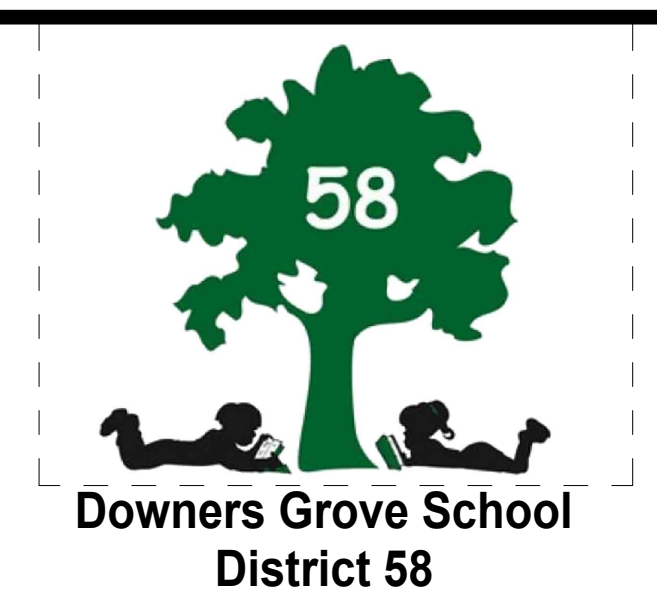

Wight

Wight & Company
wightco.com
2500 North Frontage Road
Darien, IL 60561
P 630.969.7000
F 630.969.7979

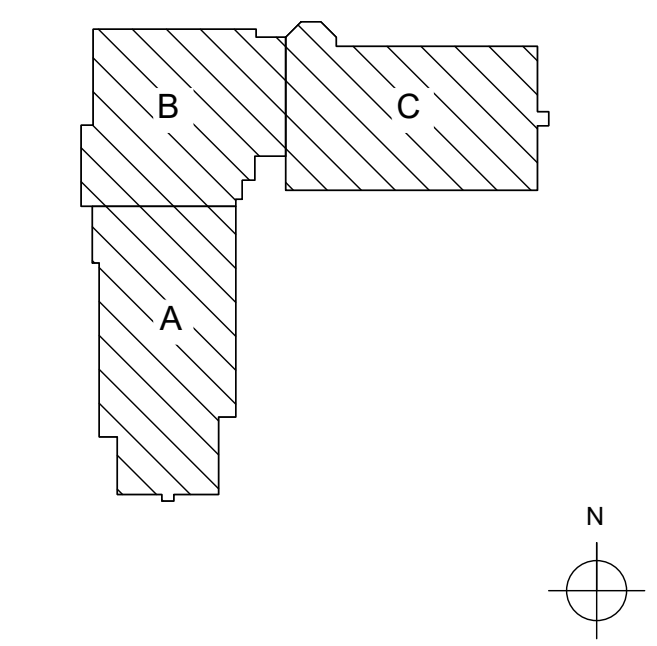

NOT FOR
CONSTRUCTION

REV	E-RATE RFP DESCRIPTION	12/18/2023 DATE
-----	------------------------	-----------------

HIGHLAND ELEMENTARY SCHOOL

3935 HIGHLAND AVE.
DOWNERS GROVE, IL 60515

TECHNOLOGY PLAN - AREA C

SENTINEL
2550 WARRENVILLE ROAD
DOWNERS GROVE, ILLINOIS 60515
630.769.4300
www.sentinel.com

Project Number:
220281
Drawn By:
-
Sheet:

Bicsi
REGISTERED COMMUNICATIONS
CONSTRUCTION DESIGNER
EXPIRES 12/31/23
Reg. No. 119887
[Signature]

T1.2

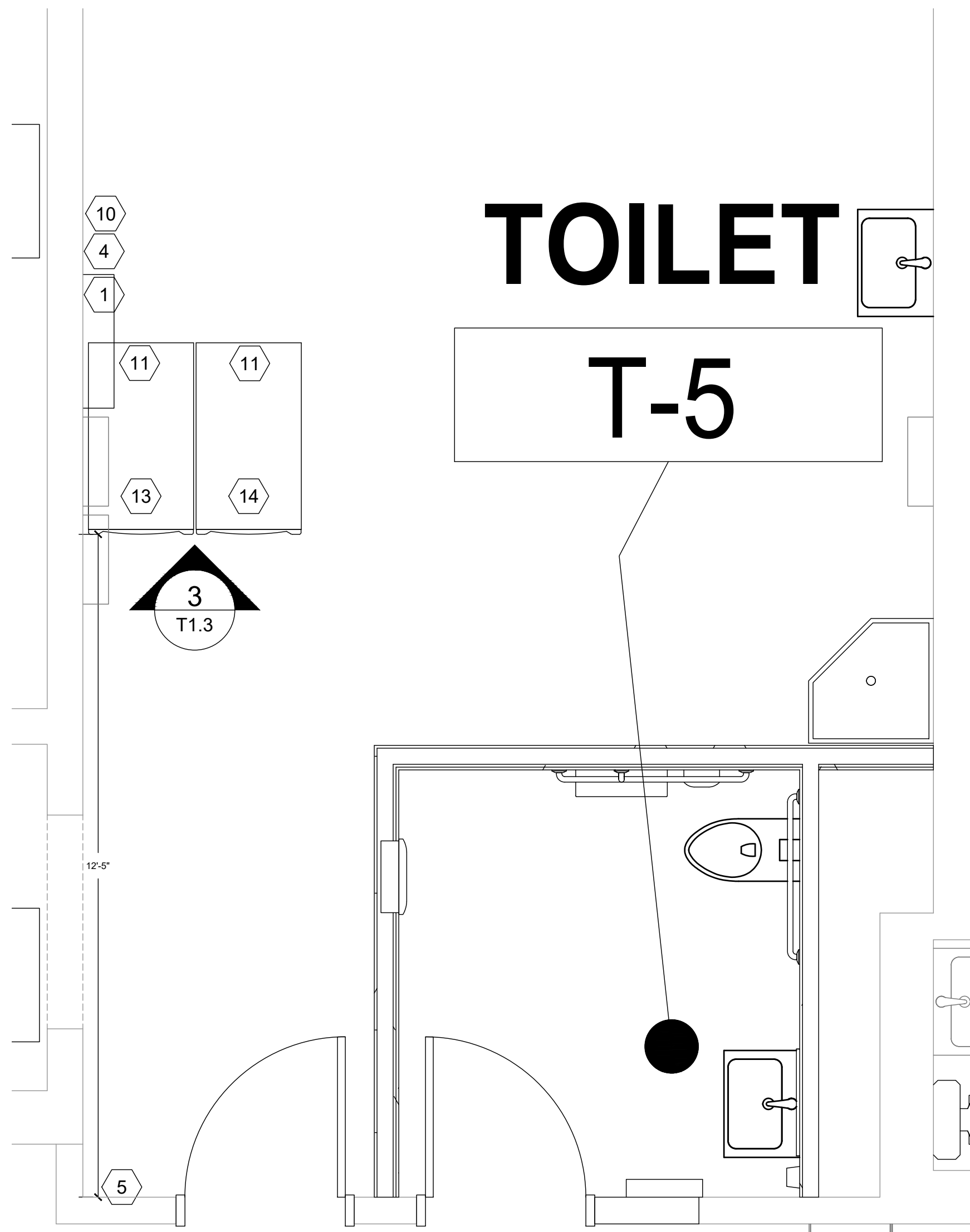

1 EQUIPMENT LAYOUT
PLAN VIEW
1/2" = 1' - 0"

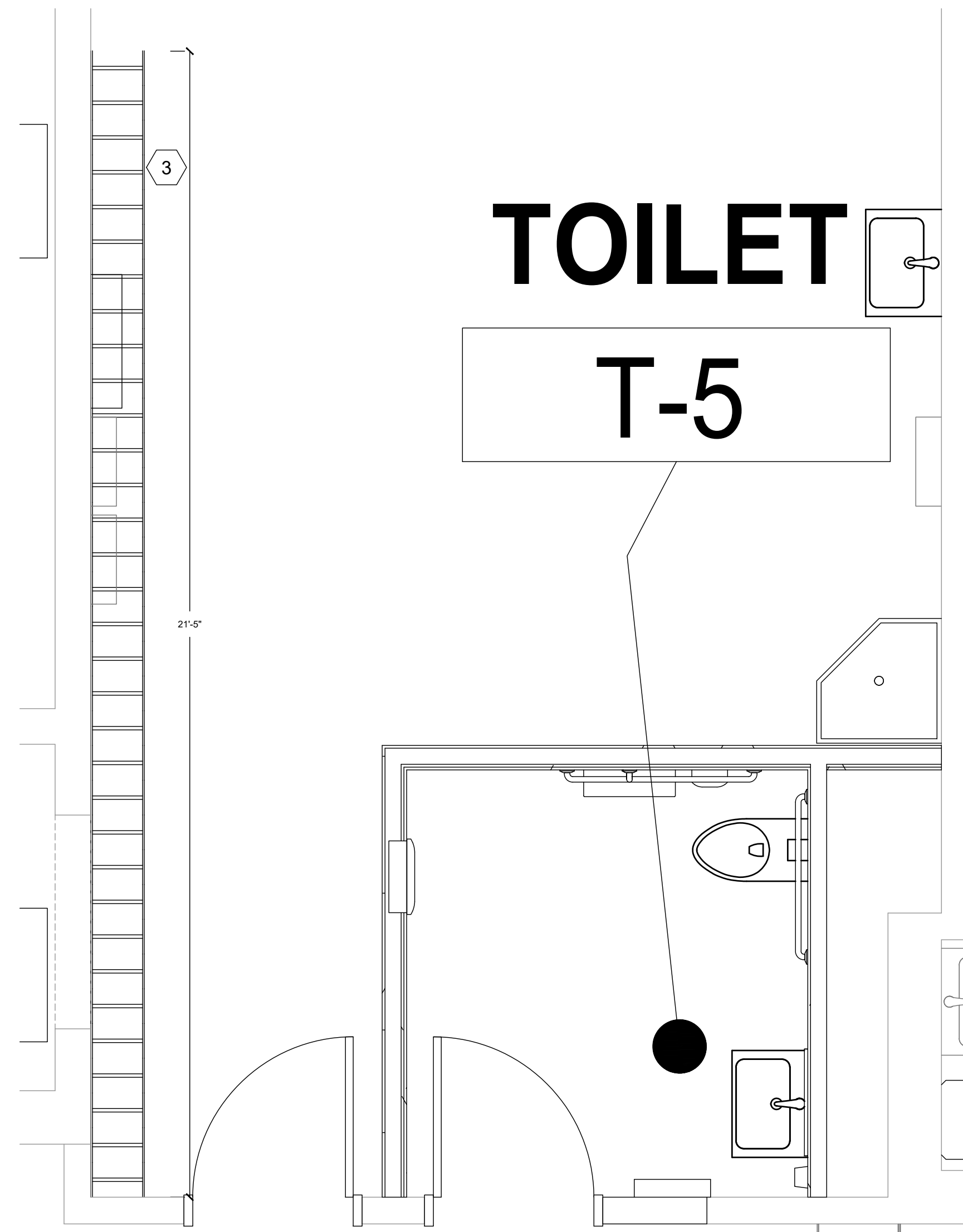

2 CABLE TRAY LAYOUT
PLAN VIEW
1/2" = 1' - 0"

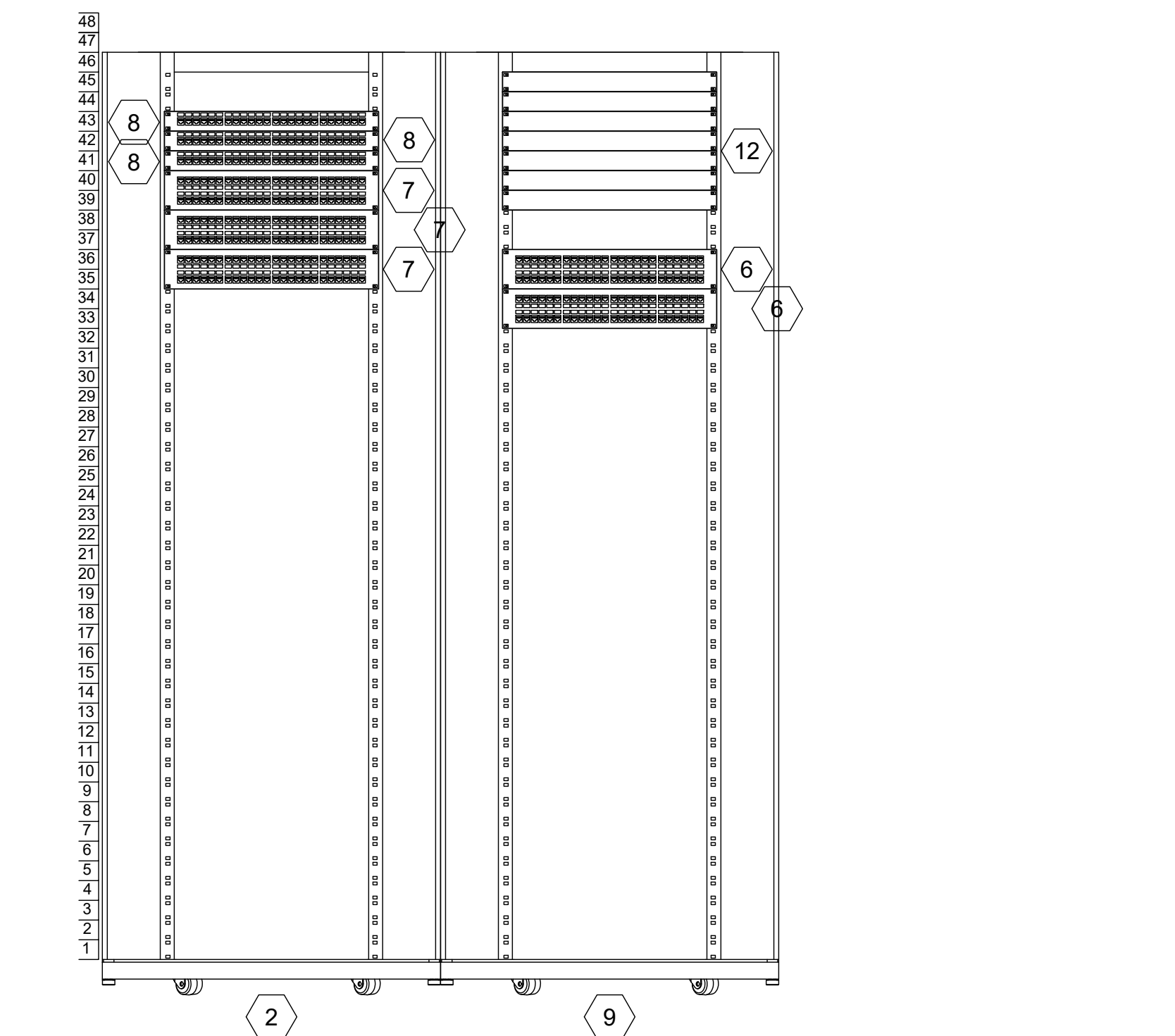

3 CABINET LAYOUT
ELEVATION VIEW - FRONT
1" = 1' - 0"

DRAWING KEYNOTES:

- 1 3/4" FIRE-RATED (OR PAINTED WITH A MINIMUM OF THREE (3) COATS FIRE RETARDANT PAINT) A-C GRADE VOID FREE PLYWOOD SHEETING SHALL BE INSTALLED ON THE ENTIRE LENGTH OF THIS WALL. THE PLYWOOD SHALL BE MOUNTED SO THAT SUCH THAT THE TOP OF THE PLYWOOD IS 8" - 6" AFF AND THE BOTTOM EDGE OF THE PLYWOOD IS 6" AFF.
- 2 EXISTING ENCLOSED EQUIPMENT CABINET RELOCATED FROM EXISTING STORAGE ROOM A113.
- 3 CIC SUPPLIED AND INSTALLED 12-INCH WIDE LADDER CABLE TRAY - CPI PART #10250-712 OR EQUIVALENT. TRAY TO BE MOUNTED SUCH THAT THE BOTTOM OF THE TRAY IS 7- FEET, 6-INCHES AFF.
- 4 TELECOMMUNICATIONS MAIN GROUNDING BUSBAR MOUNTED AT 8- FEET AFF.
- 5 ELECTRICAL CONTRACTOR FURNISHED AND INSTALLED EMT HORIZONTAL SLEEVES TO ALLOW STATION AND BACKBONE CABLING TO ENTER THE ROOM. THE ENDS OF THE SLEEVES SHALL BE REAMED AND BUSHED, AND EXTEND A MINIMUM OF 2-INCHES INTO THE ROOM. EXACT PLACEMENT, SIZE, QUANTITY, AND ROUTING OF THE SLEEVES SHALL BE COORDINATED WITH OTHER TRADES.
- 6 CIC SUPPLIED AND INSTALLED CATEGORY 6 2U 48-PORT PATCH PANEL TO SUPPORT TERMINATION OF HORIZONTAL STATION CABLING FOR PAGING SYSTEM COMPONENTS. REFER TO SPECIFICATION FOR EXACT REQUIREMENTS.
- 7 CIC SUPPLIED AND INSTALLED CATEGORY 6 2U 48-PORT PATCH PANEL TO SUPPORT TERMINATION OF HORIZONTAL STATION CABLING. REFER TO SPECIFICATION FOR EXACT REQUIREMENTS.
- 8 CIC SUPPLIED AND INSTALLED CATEGORY 6A 1U 24-PORT PATCH PANEL TO SUPPORT WIRELESS ACCESS POINT CABLING CONNECTIVITY REQUIREMENTS. REFER TO SPECIFICATION FOR EXACT REQUIREMENTS.
- 9 CIC SUPPLIED AND INSTALLED ENCLOSED EQUIPMENT CABINET TO HOUSE THE PAGING SYSTEM COMPONENTS.
- 10 ELECTRICAL INSTALLATION CONTRACTOR SUPPLIED AND INSTALLED NEMA 5-20 QUAD RECEPTACLE MOUNTED AT STANDARD BUILDING HEIGHT. REFER TO ELECTRICAL DRAWINGS FOR EXACT REQUIREMENTS.
- 11 ELECTRICAL INSTALLATION CONTRACTOR SUPPLIED AND INSTALLED NEMA 5-20 QUAD RECEPTACLE MOUNTED IN THE REAR OF THE CABINET AT THE TOP. REFER TO ELECTRICAL DRAWINGS FOR EXACT REQUIREMENTS.
- 12 CIC SUPPLIED AND INSTALLED PAGING SYSTEM COMPONENTS. REFER TO PAGING SYSTEM DETAILS DRAWING FOR EXACT REQUIREMENTS.



Wight

Wight & Company
wightco.com
2500 North Frontage Road
Darien, IL 60561
P 630.969.7000
F 630.969.7979

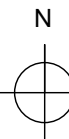
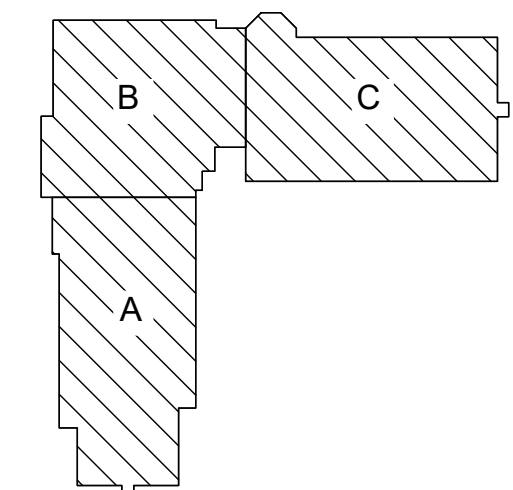

NOT FOR CONSTRUCTION

REV	E-RATE RFP DESCRIPTION	12/18/2023 DATE
-----	------------------------	-----------------

HIGHLAND ELEMENTARY SCHOOL

3935 HIGHLAND AVE.
DOWNERS GROVE, IL 60515

MDF PLAN

SENTINEL
2550 WARRENVILLE ROAD
DOWNERS GROVE, ILLINOIS 60515
630.769.4300
www.sentinel.com

Project Number:
220281
Drawn By:
-
Sheet:

Bicsi
REGISTERED COMMUNICATIONS DISTRIBUTION DESIGNER
EXPIRES 12/31/23
Reg. No. 119887

T1.3

Hillcrest Elementary School - D58 Referendum Improvements

Downer's Grove School District 58

1435 Jefferson Ave

Downers Grove, IL 60516

220281

December 18, 2023

ISSUED FOR E-RATE RFP

NOT FOR CONSTRUCTION

PROJECT TEAM		DRAWING SHEET INDEX		LOCATION
<p>CLIENT DOWNERS GROVE GRADE SCHOOL DISTRICT 58 2300 WARRENVILLE RD, SUITE 200 NE DOWNERS GROVE, IL 60516 PHONE: (630)719-5859 CONTACT: KEVIN BARTO</p> <p>STRUCTURAL ENGINEER WIGHT & COMPANY 2500 NORTH FRONTAGE ROAD DARIEN, IL 60561 PHONE: (630)969-7000 FAX: (630)969-7979 CONTACT: MATT AQUINO Design Firm Registration #184-000451</p> <p>TECHNOLOGY SERVICES SENTINEL TECHNOLOGIES 2550 WARRENVILLE RD. DOWNERS GROVE, IL 60515 PHONE: (630) 769-4284 CONTACT: FRANK KRISTOFF</p>	<p>ARCHITECT WIGHT & COMPANY 2500 NORTH FRONTAGE ROAD DARIEN, IL 60561 PHONE: (630)969-7000 FAX: (630)969-7979 CONTACT: AMY TIBERI Design Firm Registration #184-000451</p> <p>PLUMBING & FIRE PROTECTION ENGINEER WIGHT & COMPANY 2500 NORTH FRONTAGE ROAD DARIEN, IL 60561 PHONE: (630)969-7000 FAX: (630)969-7979 CONTACT: BILL BAUER Design Firm Registration #184-000451</p> <p>MECHANICAL ENGINEER WIGHT & COMPANY 2500 NORTH FRONTAGE ROAD DARIEN, IL 60561 PHONE: (630)969-7000 FAX: (630)969-7979 CONTACT: SUDESH SARAF Design Firm Registration #184-000451</p> <p>ELECTRICAL ENGINEER WIGHT & COMPANY 2500 NORTH FRONTAGE ROAD DARIEN, IL 60561 PHONE: (630)969-7000 FAX: (630)969-7979 CONTACT: ANTHONY SULLENTRUP Design Firm Registration #184-000451</p>	<p>BUILDING CODE DATA</p> <p>1. APPLICABLE CODES BUILDING CODE: 2015 INTERNATIONAL EXISTING BUILDING CODE MECHANICAL CODE: 2015 INTERNATIONAL MECHANICAL CODE ELECTRICAL CODE: 2014 NATIONAL ELECTRICAL CODE PLUMBING CODE: ILLINOIS PLUMBING CODE - CURRENT EDITION ACCESSIBILITY CODE: 2018 ILLINOIS ACCESSIBILITY CODE ENERGY CODE: 2018 INTERNATIONAL ENERGY CONSERVATION FIRE CODE: 2015 INTERNATIONAL FIRE CODE OTHER CODES: 2015 IBC FUEL GAS CODE</p> <p>2. GENERAL BUILDING DESCRIPTION GROSS BUILDING AREA, EXISTING: 43,734 SF GROSS BUILDING AREA, TOTAL (NEW & EXISTING): 43,734 SF</p> <p>3. BUILDING OCCUPANCY TYPE SECTION 302 OCCUPANCY CLASSIFICATION: E</p> <p>4. CONSTRUCTION TYPE SECTION 503, 602 CONSTRUCTION TYPE: IIB, IV ROOF CLASSROOM WINGS FIRE RESISTANCE RATING REQUIREMENTS: TABLE 601 STRUCTURAL FRAME: 0 HR BEARING WALLS (EXTERIOR) (ALSO SEE TABLE 602): 0 HR BEARING WALLS (INTERIOR): 0 HR NON-BEARING WALLS (EXTERIOR): SEE TABLE 602 NON-BEARING WALLS (INTERIOR): 0 HR FLOOR CONSTRUCTION: 0 HR ROOF CONSTRUCTION: 0 HR EXTERIOR WALL FIRE SEPARATION DISTANCE: TABLE 602 LESS THAN 5': 1 HR LESS THAN OR EQUAL TO 5' TO LESS THAN 10': 1 HR LESS THAN OR EQUAL TO 10' TO LESS THAN 30': 0 HR GREATER THAN OR EQUAL TO 30': 0 HR</p> <p>ADDITIONAL CODE IEBC CHAPTER 4 PRESCRIPTIVE COMPLIANCE PATH DICTATE WHERE FIRE RATING WILL BE REQUIRED COMMON PATH OF EGRESS - 75 FEET MAX. MAX TRAVEL DISTANCE - 200 FEET</p>	<p>GENERAL G0.00 G0.02</p> <p>TECHNOLOGY T0.0 T1.0 T1.1 T1.2 T1.3 T1.4</p> <p>COVER SHEET GENERAL INFORMATION, SYMBOLS, NOTES & ABBREVIATIONS</p> <p>LEGEND AND GENERAL NOTES TECHNOLOGY PLAN - AREA A TECHNOLOGY PLAN - AREA B TECHNOLOGY PLAN - AREA C TECHNOLOGY PLAN - AREA D TECHMDF ROOM LAYOUTS</p>	

ILLINOIS ENERGY CONSERVATION CODE STATEMENT OF COMPLIANCE

I HAVE PREPARED OR CAUSED TO BE PREPARED UNDER MY DIRECT SUPERVISION, THE ATTACHED PLANS AND SPECIFICATIONS AND STATE THAT, TO THE BEST OF MY KNOWLEDGE AND BELIEF AND TO THE EXTENT OF MY CONTRACTUAL OBLIGATION, THEY ARE IN COMPLIANCE WITH THE REQUIREMENTS OF THE 2015 ILLINOIS ENERGY CONSERVATION CODE

SIGNED: _____

ILLINOIS REGISTRATION NO.: _____

DATE: _____

ARCHITECT

SEAL & SIGNATURE APPLY TO GENERAL AND ARCHITECTURAL SHEETS INDICATED ON G0.01 SHEET AS G, A-SERIES, AND INCLUDED IN THE PERMIT DOCUMENTS.

SIGNED: _____

ILLINOIS REGISTRATION NO.: _____

DATE: _____

STATEMENT OF COMPLIANCE

I HAVE PREPARED OR CAUSED TO BE PREPARED UNDER MY DIRECT SUPERVISION, THE ATTACHED PLANS AND SPECIFICATIONS AND STATE THAT, TO THE BEST OF MY KNOWLEDGE AND BELIEF AND TO THE EXTENT OF MY CONTRACTUAL OBLIGATION, THEY ARE IN COMPLIANCE WITH THE ENVIRONMENTAL BARRIERS ACT (IL. REV. STAT. 1985, CH. 111 1/2, PARS. 3711 ET SEQ AS AMENDED) AND THE ILLINOIS ACCESSIBILITY CODE, 71 IL ADM. CODE 400.

SIGNED: _____

ARCHITECT/ENGINEER

ILLINOIS REGISTRATION NO.: _____

DATE: _____

FOR UNDERGROUND UTILITY LOCATIONS, CALL J.U.L.I.E.

TOLL FREE TEL. 1-800-892-0123
JULIE SUBURBS & DIGG CHICAGO

- YELLOW _____ GAS
- RED _____ ELECTRICAL
- ORANGE _____ PHONE / TV COMMUNICATION
- BLUE _____ WATER
- GREEN _____ SEWERS
- WHITE _____ SAFE TO DIG

12/12/2023 10:13:43 AM Autodesk Docs/IDG58 EMS Phase 1/220281 Hillcrest_ARCH_2023.rvt Wight & Co. © Copyright 2019 All rights reserved. No part of these documents may be reproduced, stored, or transmitted in any form or by any means, electronic, mechanical, photocopying, recording or otherwise, without the prior written consent of Wight & Co.

TYPICAL FIXTURE MOUNTING HEIGHTS, U.N.O.

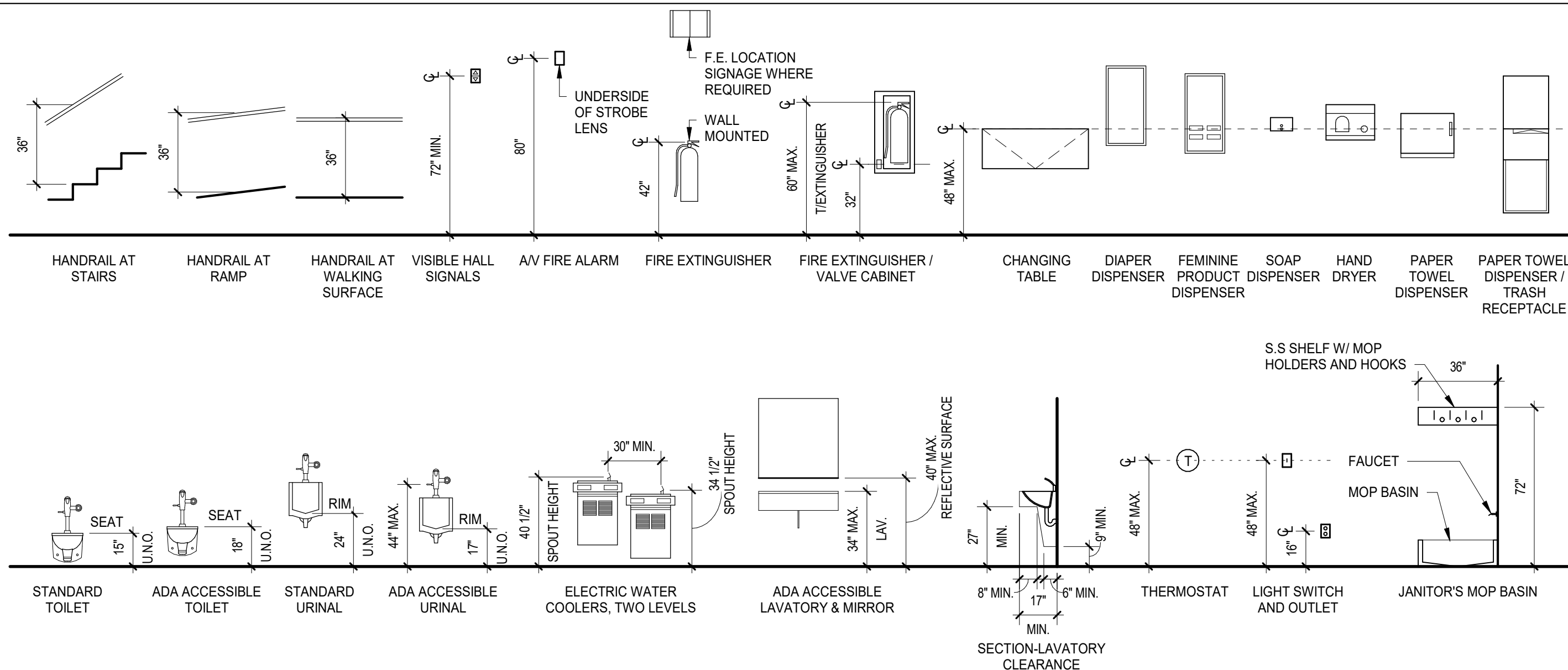

FIRESTOP SYSTEM MATRIX

NOTES:
 1. UL TEST DESIGNATION SHOWN ARE FOR GUIDANCE ONLY. CONTRACTOR SHALL PROVIDE SUBMITTALS FOR EACH BASED ON ACTUAL FIELD CONDITIONS.
 2. REFER TO THE UL THROUGH PENETRATION GUIDELINES FOR ADDITIONAL USE OF SYSTEMS.
 3. CONTRACTOR SHALL COORDINATE THE ALLOWED MOVEMENT OF A FIRESTOP SYSTEM WITH THE STRUCTURAL ENGINEERS ANTICIPATED SLAB MOVEMENT.
 4. IF ANY DEVIATIONS OCCUR FROM THE SYSTEMS SHOWN, THE CONTRACTOR SHALL SUBMIT AN ALTERNATE UL TESTED SYSTEM OR MANUFACTURER'S ENGINEERING JUDGMENT.
 5. ALL EXISTING CORRIDOR WALLS ARE 1 HOUR RATED. PROVIDE FIRE STOPPING AS APPLICABLE.

THROUGH-PENETRATIONS

DESCRIPTION	CONCRETE FLOOR OR BLOCK WALLS	GYPSUM WALLS	GYPSUM SHAFT WALLS
BLANK OPENING	CAJ-0090 FA-0014	WL-0012 WL-0040	
METAL PIPE	CAJ-1226 FA-1016	WL-1054 WL-1297	WL-1205 WL-1380
PLASTIC PIPE	CAJ-2109 FA-2054	WL-2078 WL-2128	
INSULATED PLASTIC PIPE	CAJ-5320	WL-5225	
CABLE BUNDLE	CAJ-3095 FA-3007	WL-3065 WL-3334 WL-3384	WL-3161
CABLE TRAYS	CAJ-4071 CAJ-4083	WL-4011	
METAL PIPE WITH GLASS FIBER OR POLYISO INSUL.	FA-5032 CAJ-5091 FA-5017	WL-5029 WL-5257	WL-5244
METAL PIPE WITH AB/PVC INSUL.	CAJ-5090 FA-5032 FA-5015	WL-5028 WL-5257	WL-5143
MISC. ELECTRICAL/BUSWAY	CAJ-8017 CAJ-8042	WL-6019	
SHEET METAL DUCT/RECTANGULAR	CAJ-7051	WL-7040 WL-7155 WL-7059	
SHEET METAL DUCT/ROUND	CAJ-7084	WL-7042 WL-7153	WL-7068
MULTIPLE PENETRATIONS	CAJ-8143 FA-8012 FA-5032	WL-8065 WL-8079 WL-8071	WL-8098

ABBREVIATIONS

ACCESS.	ACCESSIBLE	MAS.	MASONRY
ACT.	AMERICAN CONCRETE INSTITUTE	MFR./MANUF.	MANUFACTURER
ADA	AMERICANS WITH DISABILITIES ACT	MDF	MEDIUM DENSITY FIBERBOARD
ACoust.	ACOUSTICAL	MIN	MILLIMETERS
AC	ACOUSTICAL CEILING TILE	MISC.	MISCELLANEOUS
AF.F.	ABOVE FINISHED FLOOR	MHO	MAGNETIC HOLD OPEN
AL.T.	ALTERNATE	M.O.	MASONRY OPENING
ALUM./AL.	ALUMINUM	MTL	METALS
APPR.	APPROXIMATE	NEG	NOT IN CONTRACT
ARCH.	ARCHITECTURAL	N.I.C.	NUMBER
ASTM.	AMERICAN SOCIETY FOR TESTING AND MATERIALS	NTS	NOT TO SCALE
@	AT	OC.	ON CENTER
AV	AUDIO VISUAL BOARD	OD.	OUTSIDE DIAMETER
BLDG.	BUILDING	ORD.	OVERFLOW ROOF DRAIN
BM	BEAM	P.B.	PIPE BOLLARD
B/O	BOTTOM OF BREAK CABINET	PERS.	PERSON
BRK.	BREAK	PL./P LAM.	PLATE
CAB	CABINET	PLY	PLYWOOD
CC	CENTER TO CENTER	PP	PLASTIC LAMINATE
C	CENTERLINE	R	ROOF
CJ	CENTRAL JOINT	PSF.	POUNDS PER SQUARE FOOT
CMU	CONCRETE MASONRY UNITS	PSI	POUNDS PER SQUARE INCH (PAINTED)
COL.	COLUMN	PT/PTD	PRESTRESS TREATED RADIUS
CLG.	CLEAR	RCP	REFLECTED CEILING PLAN
CLR.	CLEAR	RD	ROAD DRAIN
CONC.	CONCRETE	RESTRM.	RESTROOM
CONT.	CONTINUOUS	R.O.	ROUGH OPENING
CONTR.	CONTRACTOR	RTU	ROOF TOP UNIT
CORR.	CORRIDOR	SABF	SOUND ATTENUATION FIBER BATT INSULATION
CPT.	CARPET	SC	SEALED CONCRETE SCHEDULE
CR.	ACCESS CARD READER	SCHD./SC	SCHEDULE
CR.	CERAMIC TILE	HED.	HED
CT	DEMOLITION	SD	SHOULDER
CT	DIA.	SF	SQUARE FEET
CT	DIMS.	SGFT.	STRUCTURAL GLAZED FACING TILE
CT	DN.	SHT.	SHEET
CT	DR.	SIM.	SIMILAR
CT	DS	SJ.	STEEL JOINT INSTITUTE
CT	DOWN SPOUT	S.M.	SHEET METAL SPACES
CT	DWG.S.	SPA	SPECIFICATIONS
CT	EA.	SPEC.	SPECIFICATIONS
CT	EIFS	ST.	STONE TILE
CT	EXT	STC	SOUND TRANSMISSION COEFFICIENT
CT	ELEV.	STB.	STONE TILE BASE
CT	ELEV.	STL	STEEL
CT	ELEV.	STL	STEEL ANGLE
CT	E.J.	STL/SS	STAINLESS STEEL STORAGE
CT	EQ.	STR.	STRUCTURAL SHEET VINYL
CT	EQUIP.	SV	SYNTHETIC TOP OF
CT	EWC	SYN	TOP OF FINING
CT	EXP	T/	TPNT
CT	EXT	T/FTG.	TEXTURED PAINT
CT	EXT.	TPNT	TYPICAL
CT	EXIST.	TYP	TYPICAL
CT	EXIST.	UNO.	UNLESS NOTED OTHERWISE
CT	ETR	USGS.	UNITED STATES GEOLOGICAL SURVEY
CT	FCD	VB	VINYL BASE
CT	FEC	VCT.	VCT. COMPOSITION TILE
CT	FF	VERT.	VERTICAL
CT	FIN.	V.I.F.	VERIFY IN FIELD
CT	FL/FLR.	V.V.C.	VINYL WALL COVERING
CT	FOUND.	WC	WATER CLOSET
CT	FT.	WD	WOOD
CT	FTG.	W	WOMENS
CT	GA	W/O	WITH
CT	GALV.	W/O	WITHOUT
CT	GWB/	WWF.	WELDED WIRE FABRIC
CT	GYP. BD.		
CT	HD		
CT	HM		
CT	HOR.		
CT	HP		
CT	HT/HTG.		
CT	HVAC		
CT	IN		
CT	INSUL		
CT	INT		
CT	JT.		
CT	LAV		
CT	LINO.		
CT	LBS.		
CT	L.P.		
CT	LVL.		
CT	M		
CT	MAT.		
CT	MAX.		

GENERAL NOTES

- WORK, MATERIALS AND METHODS SHALL BE IN CONFORMANCE WITH THE CODES, ORDINANCES AND REGULATIONS OF GOVERNMENTAL AGENCIES HAVING JURISDICTION AT THE PROJECT LOCATION.
- UNLESS OTHERWISE INDICATED IN THE CONSTRUCTION DOCUMENTS AS BEING NOT IN CONTRACT (N.I.C.) OR EXISTING, ITEMS, MATERIALS AND INSTALLATION OF SAME ARE PART OF THE CONTRACT AS DEFINED BY THE CONSTRUCTION DOCUMENTS. THE CONTRACTORS SHALL PROVIDE AND INSTALL ACCESSORIES, COMPONENTS AND ASSEMBLIES REQUIRED FOR THE WORK DEPICTED OR SPECIFIED.
- EACH CONTRACTOR SHALL BE RESPONSIBLE FOR VERIFYING DIMENSIONS AND EXISTING CONDITIONS BEFORE COMMENCING WORK. REPORT DISCREPANCIES AND/OR POTENTIAL PROBLEMS PRIOR TO PROCEEDING WITH AFFECTED WORK.
- FIRE-RATED ASSEMBLIES SHALL BE INSTALLED, LABELED, AND INSPECTED IN ACCORDANCE WITH THE APPLICABLE CODES. THIS INCLUDES FIRE DAMPERS OR FIRE DOORS PROVIDED WHERE AIR DUCTS OR OPENINGS PENETRATE FIRE RATED SURFACES. PENETRATIONS OF RATED FIRE RESISTIVE CONSTRUCTION SHALL BE PROTECTED WITH APPROVED FIRE ASSEMBLIES.
- PENETRATIONS THROUGH SURFACE SHALL BE SEALED WITH SEALANT MATERIAL PER SPECIFICATIONS. FOR PLUMBING, FIRE SPRINKLER AND ELECTRICAL SYSTEMS.
- IN THE EVENT OF DISCREPANCIES BETWEEN DRAWINGS AND/OR SPECIFICATIONS, THE MORE COSTLY OR MORE RESTRICTIVE CONDITIONS SHALL BE DEEMED THE CONTRACT REQUIREMENT UNLESS OTHERWISE STATED IN WRITING.
- PROVIDE GALVANIC PROTECTION BETWEEN DISSIMILAR MATERIALS, WHERE REQUIRED.
- KEEP PIPING AS CLOSE TO WALLS AS POSSIBLE UNLESS NOTED OTHERWISE.
- NO CONTRACTORS SHALL CLOSE OR OBSTRUCT STREETS, DOCKS, ALLEYS OR WALKS. NO MATERIALS ARE TO BE PLACED OR STORED IN STREETS, ALLEYS OR WALKS. DEBRIS IS TO BE REMOVED COMPLETELY FROM THE PREMISES.
- CONTRACTORS SHALL PROVIDE AND ARE SOLELY RESPONSIBLE AND LIABLE FOR PUBLIC AND EMPLOYEE PROTECTION AS NECESSARY AND AS REQUIRED BY THE CODES, INCLUDING EXTERIOR, INTERIOR PEDESTRIAN AND TRAFFIC BARRIERS. EXISTING EXIT CORRIDORS, PATHS OF EXITS, STAIRWAYS, OR EXIT SIGNAGE, MUST HAVE A CLEAR MEANS OF EGRESS DURING PHASES OF CONSTRUCTION.
- CONTRACTORS WISHING TO WORK IN THE BUILDING OR ON THE BUILDING PROPERTY SHALL BE REQUIRED TO PRESENT THE PROPER CERTIFICATES OF INSURANCE. CONTRACTORS ARE REQUIRED TO BE LICENSED WITH THE LOCAL JURISDICTION. LICENSES AND BONDING ARE TO BE INCLUDED IN THE BID PER THE REQUIREMENTS IN THE SPECIFICATIONS.
- DIMENSIONS NOTED ON THE ARCHITECTURAL FLOOR PLAN REGARDING DETAILS AND PARTITION THICKNESSES ARE NOMINAL DIMENSIONS. REFER TO A8 SERIES FOR THE EXACT DIMENSION.

GRAPHIC SYMBOLS

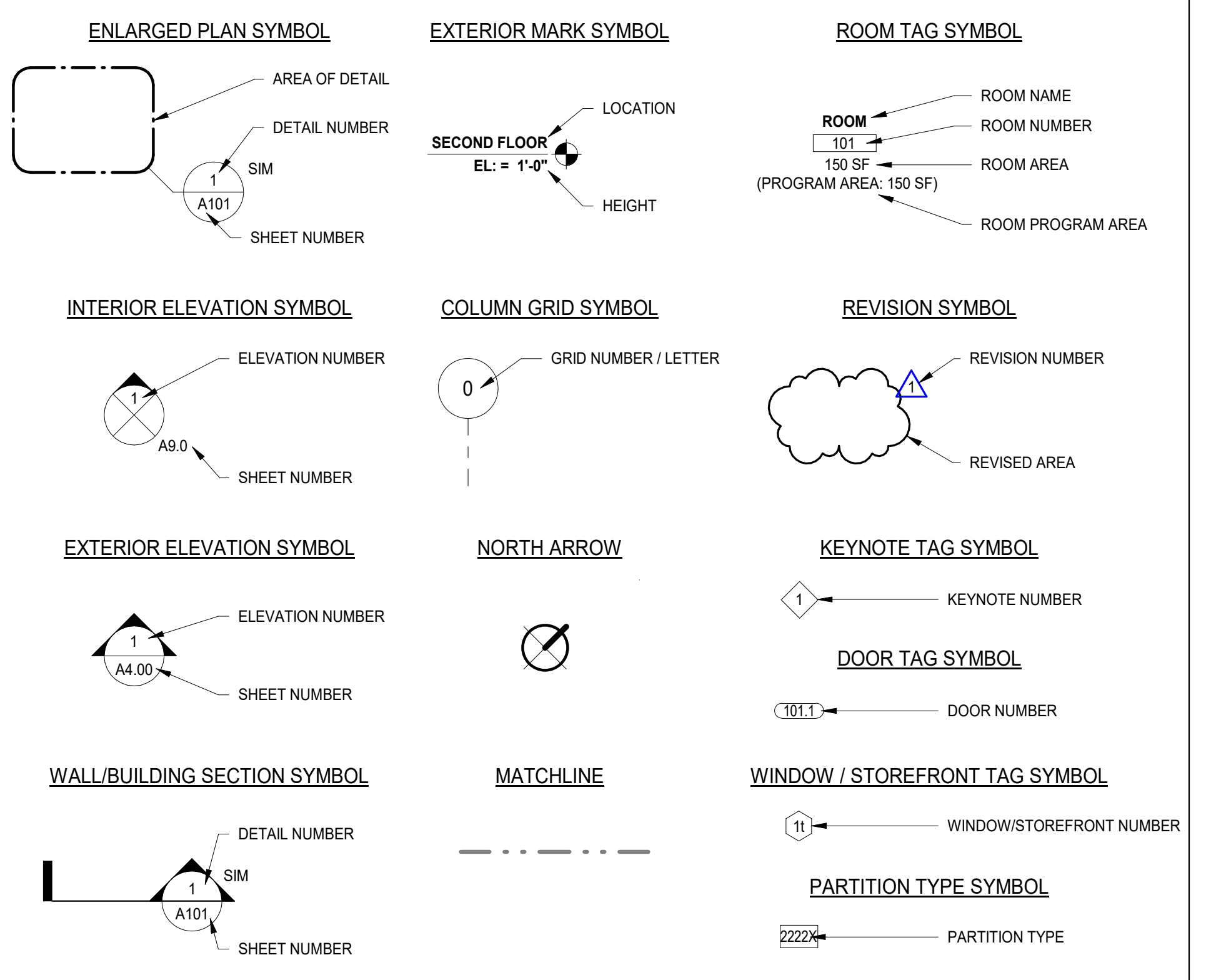

MATERIAL LEGEND

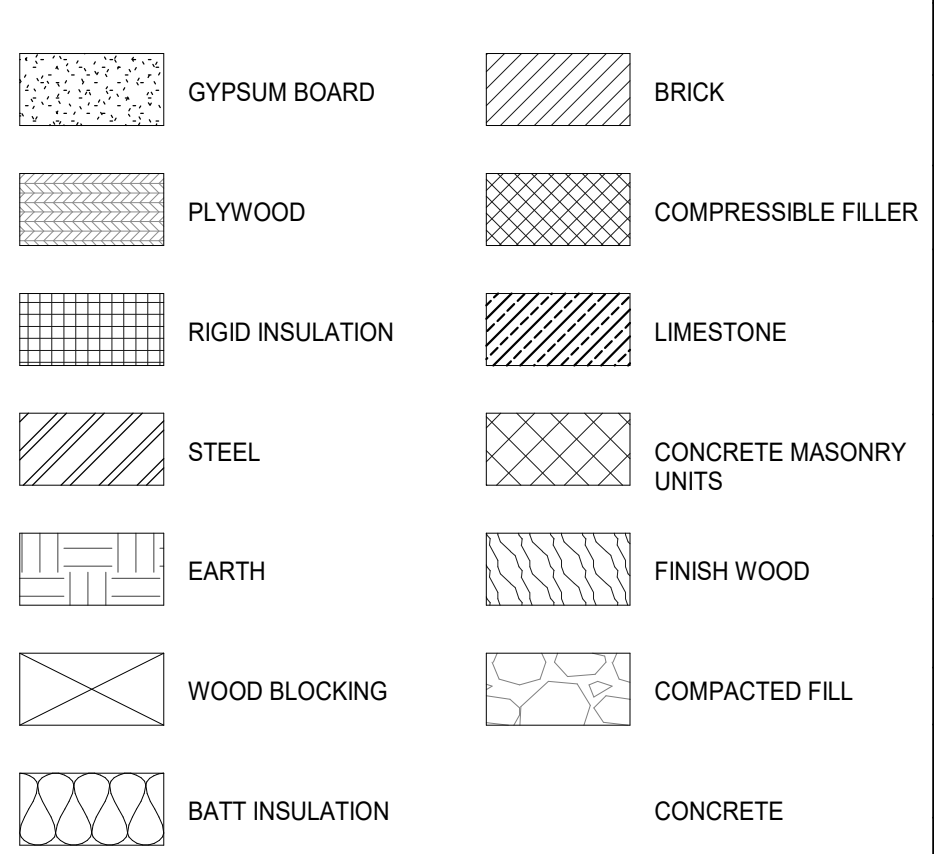

TOP OF WALL JOINTS

DESCRIPTION	CONCRETE BLOCK WALLS	GYPSUM WALLS	EXTERIOR WALL
PERP. TO METAL DECK	HWD-0042 HWD-1066/1067 HWD-0045	HWD-1037 HWD-0081	
PARALLEL TO METAL DECK	HWD-0049 HWD-1067 HWD-0184 HWD-0539	HWD-0181 HWD-0081	
PARALLEL TO STEEL BEAM	HWD-0259		
FLAT CONCRETE	HWD-1068 HWD-0209	HWD-1058 HWD-0268	
CUT TO PROFILE	HW-0324		
SHAFT WALL PARALLEL TO DECK	HWD-0570		
SHAFT WALL PERP. TO DECK	HWD-0569		
SHAFT WALL TO FLAT CONCRETE	HWD-0342 HWD-0572		

FURNISHED AND INSTALLED MATRIX.

D58 Equipment Matrix Henry Puffer

TOILET ROOM ACCESSORIES	FURNISHED BY	INSTALLED BY
PAPER TOWEL HOLDER	TOILET ROOMS	OWNER
SOAP DISPENSERS	TOILET ROOMS	OWNER
TOILET PAPER HOLDERS	TOILET ROOMS	OWNER
ALL OTHER ACCESSORIES	TOILET ROOMS	CONTRACTOR

TYPICAL DOOR LOCATION

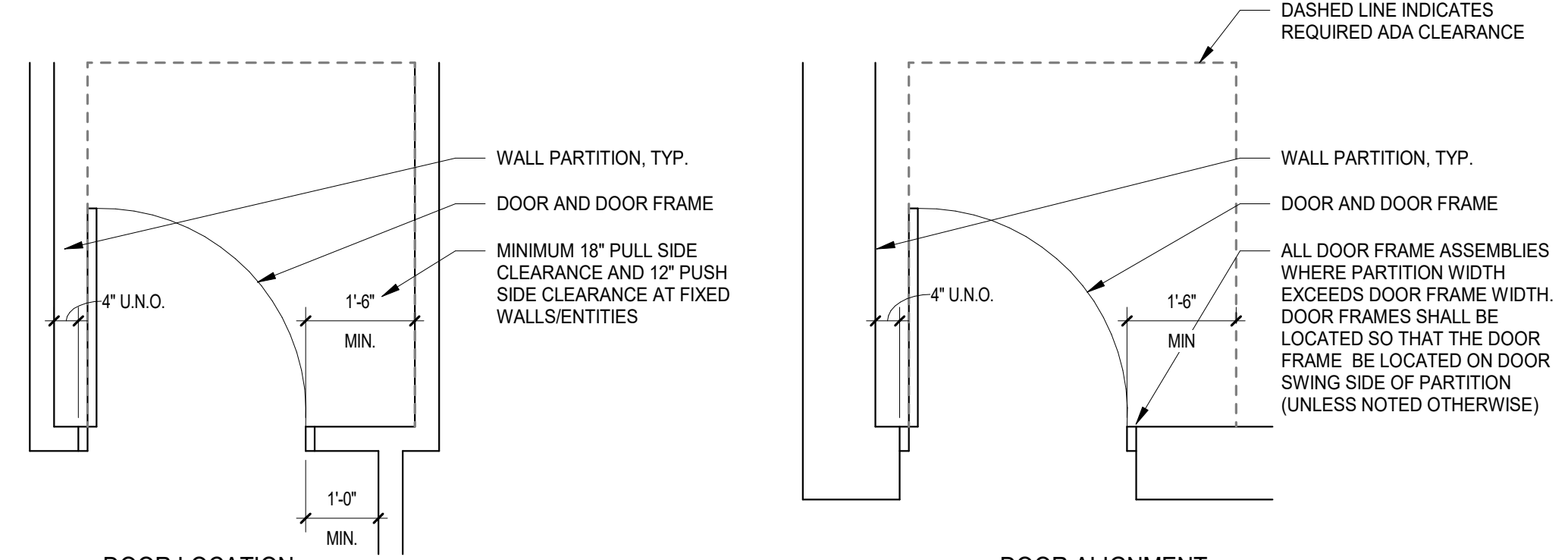

ADA ACCESSIBLE TOILET PLAN & ELEVATIONS

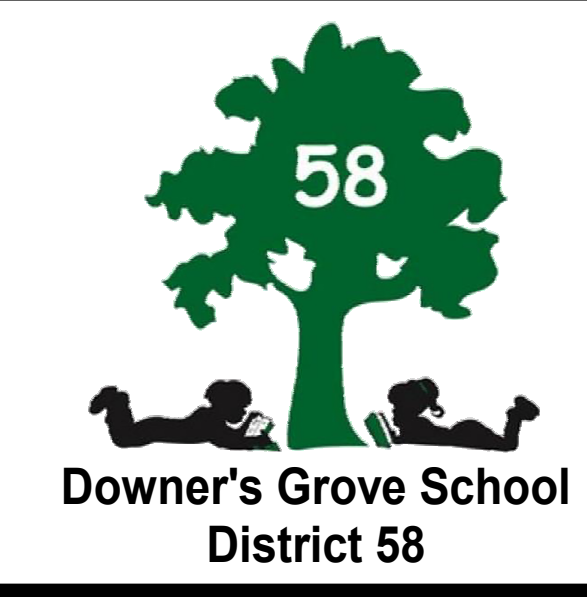
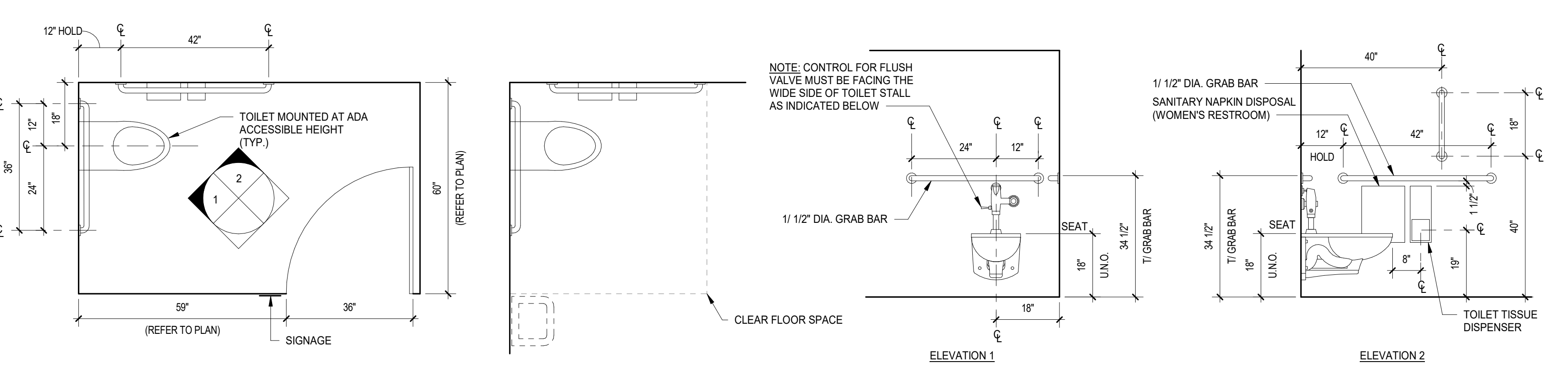

Wight & Company
wightco.com
2500 North Frontage Road
Darien, IL 60561
P 630.969.7700
F 630.969.7979

NOT FOR CONSTRUCTION

E-RATE RFP 12.18.2023
REV DESCRIPTION DATE

Hillcrest Elementary School - D58 Referendum Improvements

1435 Jefferson Ave
Downers Grove, IL 60516

GENERAL INFORMATION, SYMBOLS, NOTES & ABBREVIATIONS

Project Number: 220281
Drawn By:
Drawn By
Sheet:

12/12/2023 10:13:47 AM
Autoback.Docs\70588 EHS Phase 1\220281_Hillcrest_ARCH_2023.rvt
Wight & Co. © Copyright 2016 All rights reserved. No part of these documents may be reproduced, stored, or transmitted in any form or by any means, electronic, mechanical, photocopying, recording or otherwise, without the prior written consent of Wight & Co.

COMMUNICATIONS & LOW VOLTAGE CONDUIT REQUIREMENTS:

ALL CONDUIT RUNS SHALL BE 3/4" EMT, UNLESS NOTED OTHERWISE.

ALL BOXES SHALL BE A MINIMUM OF 4-11/16" x 4-11/16" x 2-1/8" DEEP BOX WITH A SINGLE GANG TRIM RING MOUNTED FLUSH TO THE WALL SURFACE, UNLESS NOTED OTHERWISE.

ALL MOUNTING HEIGHTS ARE TO THE CENTERLINE OF THE BACKBOX UNLESS NOTED OTHERWISE.

ALL CONDUIT SHALL BE ROUTED ABOVE CEILINGS, BELOW FLOORS, OR STUBBED UP WITHIN WALLS; NO CONDUIT SHALL BE EXPOSED UNLESS APPROVED BY THE ARCHITECT.

ALL CONDUITS IN WALLS SHALL STUB UP AT LEAST 6-INCHES ABOVE THE FINISHED CEILING. ALL STUBS SHALL BE REAMED AND BUSHED AT BOTH ENDS.

ALL CONDUIT PENETRATIONS THROUGH FIRE-RATED PARTITIONS SHALL BE SEALED AS REQUIRED BY CODE. ALL BACKBOXES MOUNTED WITHIN FIRE-RATED PARTITIONS SHALL MEET THE FIRE RATING OF THE PARTITION AS REQUIRED BY CODE.

PROVIDE PULL STRINGS IN ALL CONDUIT RUNS LONGER THAN 10-FEET.

PROVIDE PULL BOXES EVERY 100 LINEAR FEET OR AFTER TWO SUCCESSIVE 90° BENDS.

ALL JUNCTION AND PULL BOXES SHALL BE FURNISHED WITH ACCOMPANYING BLANK COVER PLATE.

ALL BOXES IN EXTERIOR LOCATIONS SHALL BE WEATHERPROOF AND WATERPROOF.

INSTRUCTIONS SHOWN IN DIMENSION LINES, DETAILS, ELEVATIONS, AND PLANS (IN THIS ORDER) TAKE PRECEDENCE OVER INSTRUCTIONS SHOWN IN LEGENDS.

CONDUIT AND CABLE ROUTING SHOWN IS SCHEMATIC AND IS NOT INTENDED TO REPRESENT INSTALLATION PATHS OR DISTANCES. ACTUAL ROUTING AND BOX LOCATIONS SHALL BE FIELD-VERIFIED FOR FEASIBILITY AND COORDINATED WITH OTHER DISCIPLINES BY THE INSTALLATION CONTRACTOR.

HORIZONTAL CONDUITS INTO EACH TECHNOLOGY AREA FROM THE EXTERIOR CEILING PLENUM ARE REQUIRED FOR CABLE ACCESS INTO THE ROOM FROM ALL LOCATIONS THROUGHOUT THE SPACE. THE ENDS OF THE CONDUITS SHALL BE REAMED AND BUSHED, AND EXTEND A MINIMUM OF 2-INCHES INTO THE ROOM.

Table with 8 columns: CABLE O.D. (") and CONDUIT TRADE SIZE AND MAXIMUM QUANTITIES OF CABLES OF THAT O.D. (3/4", 1", 1-1/4", 1-1/2", 2", 3", 4").

Table with 3 columns: NUMBER AND SIZE OF CONDUITS, PULL BOX SIZE (W x L x H IN INCHES), FOR EACH ADDITIONAL CONDUIT ENTERING THE PULL BOX, INCREASE THE WIDTH.

TECHNOLOGY DRAWING INDEX - E-RATE RFP

- T0.0 - LEGEND AND GENERAL NOTES
T1.0 - TECHNOLOGY PLAN - AREA A
T1.1 - TECHNOLOGY PLAN - AREA B
T1.2 - TECHNOLOGY PLAN - AREA C
T1.3 - TECHNOLOGY PLAN - AREA D
T1.4 - TECH/MDF ROOM LAYOUTS

TELECOMMUNICATIONS GROUNDING NOTES:

- 1. REFER TO E-SERIES DRAWINGS FOR PANEL SCHEDULING INFORMATION AND GROUNDING ELECTRODE SYSTEM DATA.
2. A SINGLE GROUND SOURCE SHALL BE PROVIDED FOR GROUNDING ALL RACKS, TRAYS AND METAL FRAMES IN THE MAIN DISTRIBUTION FRAME.
3. A TELECOMMUNICATIONS GROUNDING BUSBAR (TGB) SHALL BE INSTALLED IN ANY/ALL TELECOM ROOMS.
4. A GROUND CABLE FROM THE TMGB TO EACH TGB SHALL BE INSTALLED TO CREATE A FORMAL TELECOMMUNICATIONS BONDING BACKBONE (TBB).
5. THE CONTRACTOR SHALL PROVIDE AND INSTALL A MINIMUM #6 AWG GROUND WIRE FROM EACH OPEN RELAY RACK AND CABLE TRAY TO THE MAIN TELECOMMUNICATIONS GROUNDING BUSBAR OR TELECOMMUNICATIONS GROUNDING BUSBAR.
6. ANY PENETRATION THROUGH A FIRE-RATED WALL SHALL BE PROPERLY FIRE-STOPPED BY THE CONTRACTOR WITH THE APPROPRIATE FIRE-STOP MATERIAL PER APPLICABLE BUILDING AND ELECTRICAL CODES.
7. THE CONTRACTOR SHALL COORDINATE GROUND CABLE INSTALLATION WITH THE ARCHITECTS, MEP ENGINEERS AND THE OTHER TRADES ON THE PROJECT.
8. THE CONTRACTOR SHALL ASSUME RESPONSIBILITY FOR ANY DAMAGE TO ANY COMPONENT OF THE TELECOMMUNICATIONS GROUNDING SYSTEM DURNING INSTALLATION.
9. THE CONTRACTOR SHALL VERIFY THAT THE SIZE OF THE TMGB AND THE TGB ARE ADEQUATE TO SUPPORT THE TELECOMMUNICATIONS GROUNDING REQUIREMENTS FOR THE PROJECT.

ANSI/TIA-607-B CONDUCTOR SIZES table with columns: LENGTH IN FEET, CONDUCTOR SIZE (AWG).

ABBREVIATIONS USED IN THESE DRAWINGS:

AVIC = AUDIOVISUAL CABLING CONTRACTOR
CIC = CABLING INSTALLATION CONTRACTOR
EC = ELECTRICAL INSTALLATION CONTRACTOR
PIC = PAGING INSTALLATION CONTRACTOR
SIC = SECURITY INSTALLATION CONTRACTOR

NOTE: COORDINATE WITH THE ARCHITECT AND GENERAL CONTRACTOR FOR EXACT MOUNTING LOCATIONS PRIOR TO INSTALLATION OF ANY COMPONENTS.

THIS DRAWING SERIES IS INTENDED TO SHOW QUANTITIES. REFER TO A-SERIES AND E-SERIES DRAWINGS FOR EXACT LOCATIONS, HEIGHTS, AND PLACEMENT.

NOTE: THIS DRAWING SET INCORPORATES THREE-PART SPECIFICATIONS FOR INTERPRETATION; THEREFORE, THESE SPECIFICATIONS AND DRAWINGS SHALL BE TREATED AS A SINGLE ISSUANCE. IF EITHER COMPONENT IS NOT UTILIZED FOR BID, REVIEW, OR CONSTRUCTION, THEN CRITICAL INFORMATION IS MISSING THAT MAY AFFECT SCHEDULE AND PRICING.

NOTE: BASE BID WORK IS AS FOLLOWS:

- 1. BASE BID WORK SHALL INCLUDE ALL CABLING LOCATIONS IN THE HIGHLIGHTED AREAS
2. ALL CABLING LOCATIONS FOR PAGING SYSTEM, CAMERA, AND WALL DATA LOCATIONS THROUGHOUT THE ENTIRE SCHOOL
3. FIBER OPTIC BACKBONE CABLE

NOTE: ALTERNATE BID WORK IS AS FOLLOWS:

- 1. WIRELESS ACCESS POINT LOCATIONS THROUGHOUT THE ENTIRE SCHOOL NOT IN BASE BID AREAS
2. PROJECTOR LOCATIONS THROUGHOUT THE ENTIRE SCHOOL NOT IN BASE BID AREAS

COMMUNICATIONS LEGEND:

- 2: TWO (2) CABLE AND TWO (2) JACK LOCATION. CIC TO FURNISH AND INSTALL TWO (2) CATEGORY 6 CABLES AND TWO (2) CATEGORY 6 8P8C (RJ45) JACKS AT THIS LOCATION. REFER TO THE SPECIFICATION FOR CABLE AND JACK REQUIREMENTS. MOUNT AT +15" AFF. O.C. UNO. CIC TO COORDINATE FACEPLATE FINISH AND HEIGHT WITH ARCHITECTS.
E: EXISTING DATA LOCATION. CIC TO FURNISH AND INSTALL ONE (1) CATEGORY 6 CABLE AND ONE (1) CATEGORY 6 8P8C (RJ45) JACK AT THIS LOCATION. REFER TO THE SPECIFICATION FOR CABLE AND JACK REQUIREMENTS. CIC TO COORDINATE FACEPLATE FINISH AND HEIGHT WITH ARCHITECTS.
D: EXISTING DATA LOCATION TO BE REMOVED. CICTO FURNISH AND INSTALL A BLANK FACEPLATE AT THIS LOCATION TO COVER THE OPENING. CIC TO COORDINATE FACEPLATE FINISH AND HEIGHT WITH ARCHITECTS.
WAP: CEILING DATA LOCATION CONSISTING OF TWO (2) CATEGORY 6A 8P8C (RJ45) JACKS AND TWO (2) CATEGORY 6A CABLES TO SUPPORT CUSTOMER PROVIDED AND CIC INSTALLED WIRELESS ACCESS POINTS.
C: CEILING DATA LOCATION CONSISTING OF ONE (1) CATEGORY 6 CABLE TO SUPPORT SIC FURNISHED AND INSTALLED SURVEILLANCE CAMERA.
C: WALL MOUNTED DATA LOCATION CONSISTING OF ONE (1) CATEGORY 6 CABLE TO SUPPORT SIC FURNISHED AND INSTALLED SURVEILLANCE CAMERA.
PCL: CIC FURNISHED AND INSTALLED IP-BASED PAGING SPEAKER AND CLOCK.
CL: CIC FURNISHED AND INSTALLED IP-BASED PAGING DUAL SIDED CLOCK.
PS: CIC FURNISHED AND INSTALLED IP-BASED CEILING MOUNTED PAGING SPEAKER.
OPS: CIC FURNISHED AND INSTALLED IP-BASED OUTDOOR PAGING SPEAKER.
ST: CIC FURNISHED AND INSTALLED IP-BASED OUTDOOR STROBE.
P: CEILING DATA LOCATION CONSISTING OF TWO (2) CATEGORY 6 8P8C (RJ45) JACKS AND TWO (2) CATEGORY 6 CABLES TO SUPPORT CUSTOMER PROVIDED AND INSTALLED PROJECTORS.
PS: ONE (1) CABLE AND ONE (1) JACK LOCATION.
PS2: TWO (2) CABLE AND TWO (2) JACK LOCATION.
WAP: TWO (2) CABLE AND TWO (2) JACK LOCATION TO SUPPORT CUSTOMER PROVIDED AND CIC INSTALLED WIRELESS ACCESS POINTS.
1: ONE (1) CABLE AND ONE (1) JACK LOCATION.

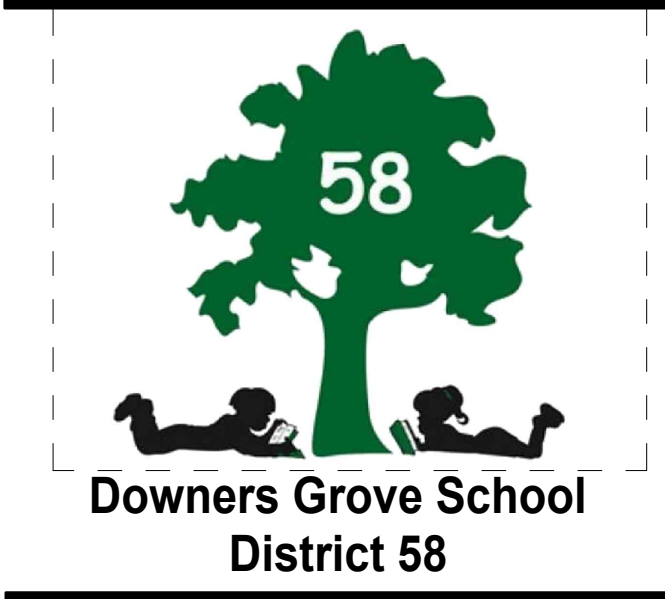

Wight logo and contact information: Wight & Company, wightco.com, 2500 North Frontage Road, Darien, IL 60561, P 630.969.7000, F 630.969.7979

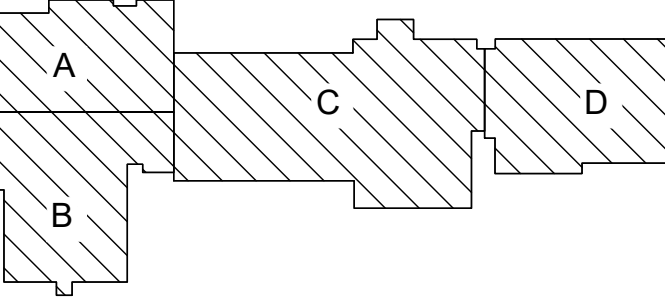

NOT FOR CONSTRUCTION (written diagonally)

Table with 3 columns: REV, E-RATE RFP DESCRIPTION, 12/18/2023 DATE

HILLCREST ELEMENTARY SCHOOL

1435 JEFFERSON AVE. DOWNERS GROVE, IL 60515

LEGEND AND GENERAL NOTES

SENTINEL logo, 2550 WARRENVILLE ROAD, DOWNERS GROVE, ILLINOIS 60515, 630.769.4300, www.sentinel.com, Bicsi logo, EXPIRES 12/31/23, Reg. No. 119887, J.A.H.

Project Number: 220281
Drawn By: -
Sheet:

T0.0

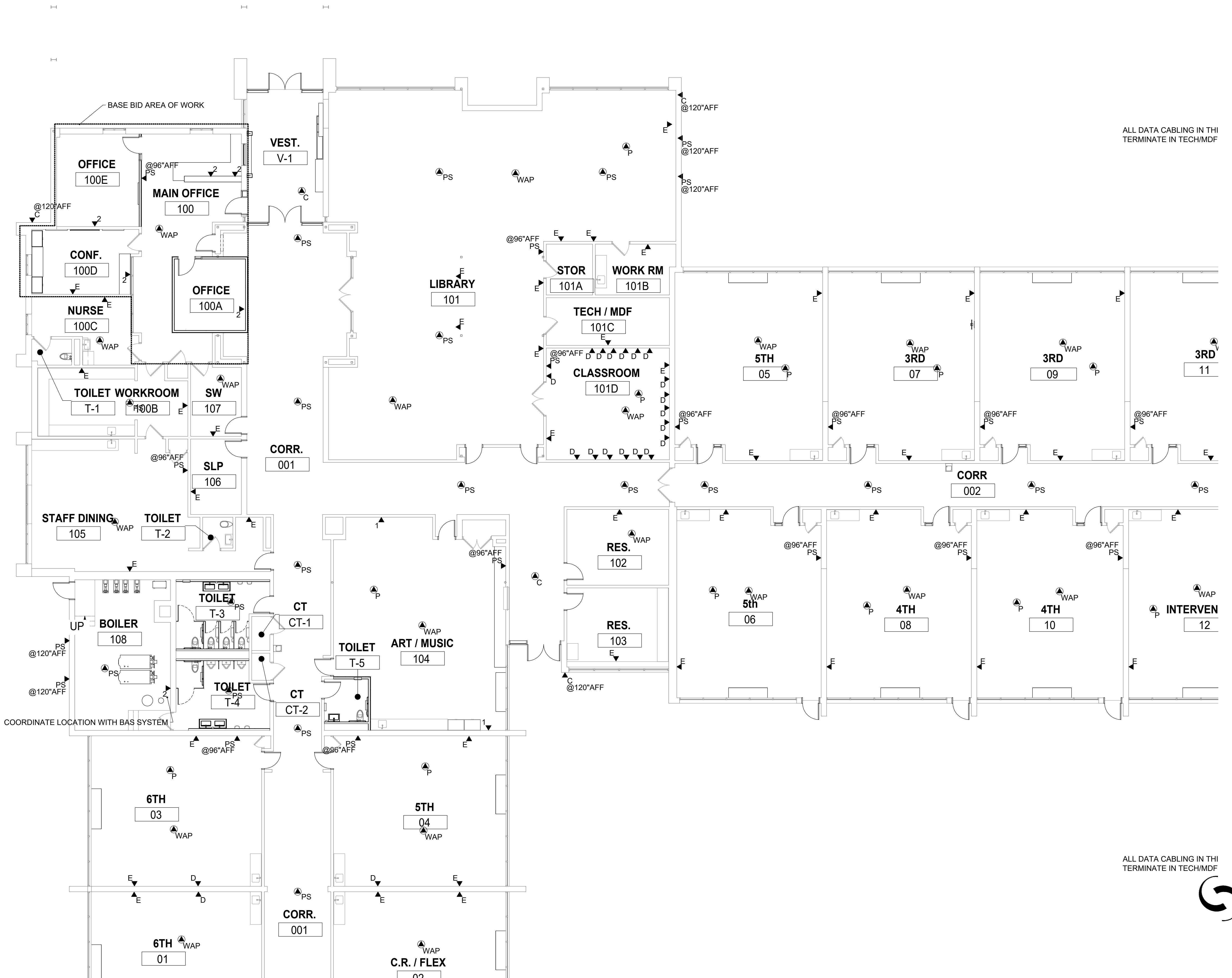

ALL DATA CABLING IN THIS TERMINATE IN TECH/MDF

ALL DATA CABLING IN THIS TERMINATE IN TECH/MDF

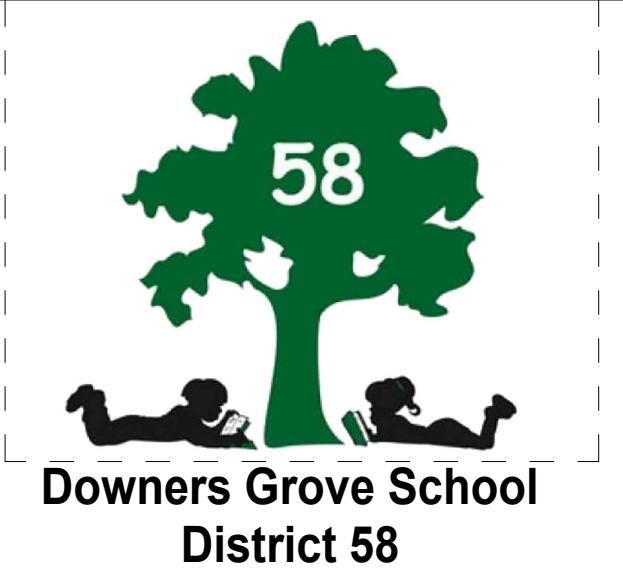

Wight

Wight & Company
wightco.com
2500 North Frontage Road
Darien, IL 60561
P 630.969.7000
F 630.969.7979

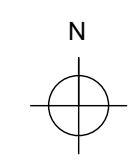
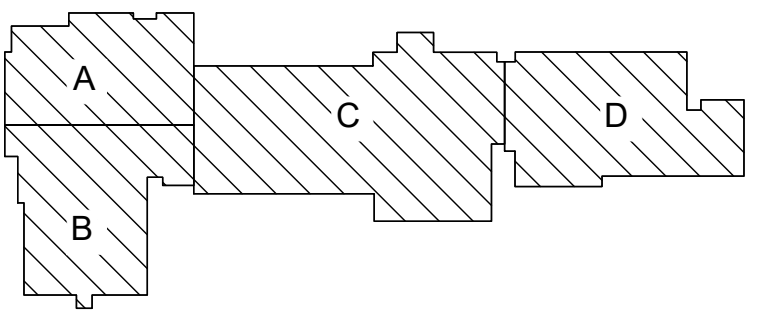

NOT FOR CONSTRUCTION

REV	E-RATE RFP DESCRIPTION	12/18/2023 DATE

HILLCREST ELEMENTARY SCHOOL

1435 JEFFERSON AVE.
DOWNERS GROVE, IL 60515

TECHNOLOGY PLAN - AREA A

Project Number:
220281
Drawn By:
-
Sheet:

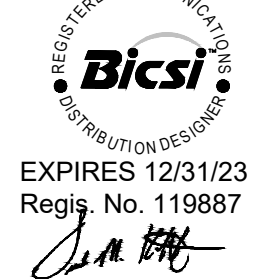

T1.0

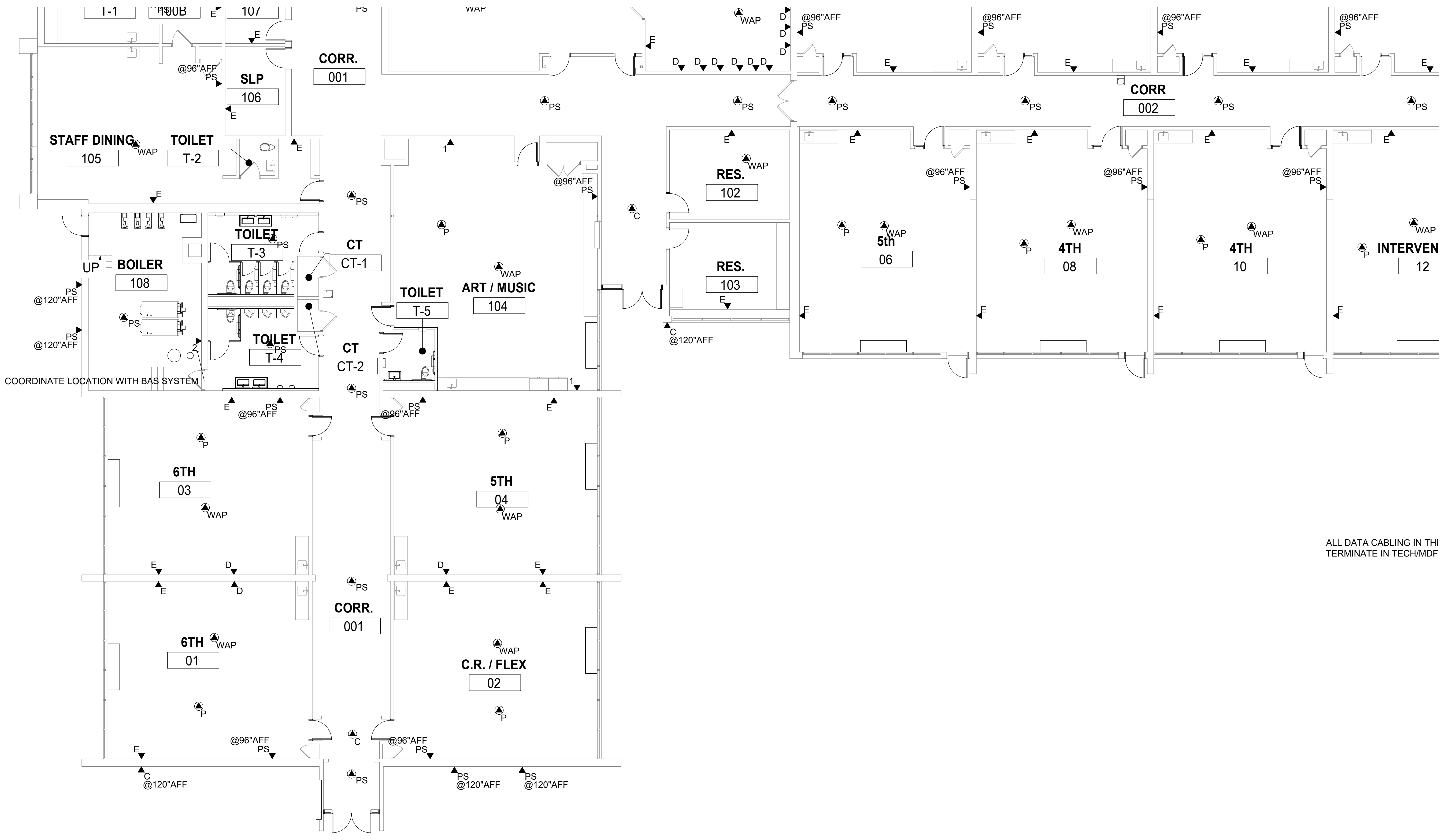

ALL DATA CABLING IN THI
TERMINATE IN TECH/MDF

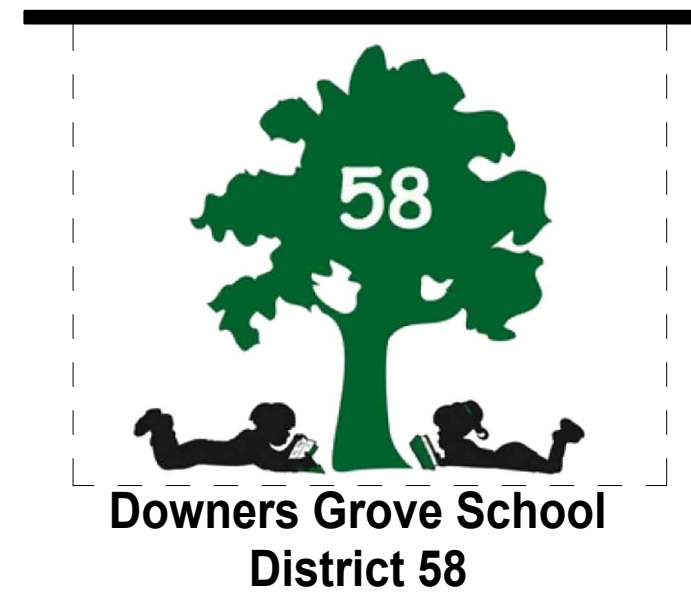

Wight

Wight & Company
wightco.com
2500 North Frontage Road
Darien, IL 60561
P 630.969.7000
F 630.969.7979

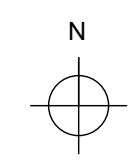
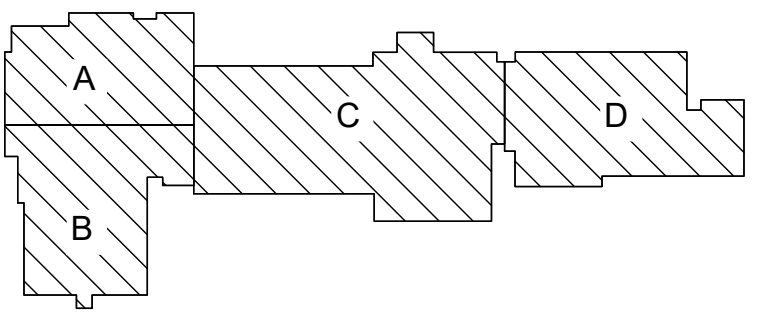

**NOT FOR
CONSTRUCTION**

REV	E-RATE RFP DESCRIPTION	12/18/2023 DATE
-----	------------------------	-----------------

HILLCREST ELEMENTARY SCHOOL

1435 JEFFERSON AVE.
DOWNERS GROVE, IL 60515
**TECHNOLOGY PLAN -
AREA B**

Project Number:
220281
Drawn By:
-
Sheet:



T1.1



Wight

Wight & Company
 wightco.com
 2500 North Frontage Road
 Darien, IL 60561
 P 630.969.7000
 F 630.969.7979

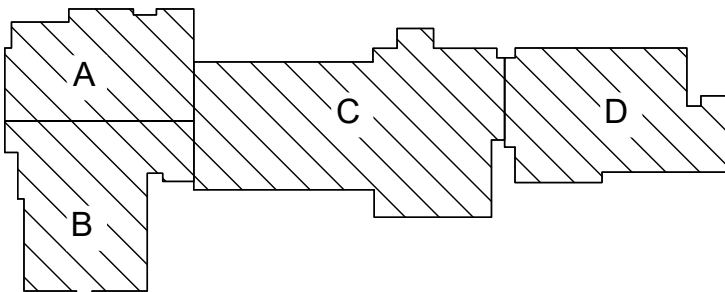

NOT FOR CONSTRUCTION

REV	E-RATE RFP DESCRIPTION	12/18/2023 DATE

HILLCREST ELEMENTARY SCHOOL

1435 JEFFERSON AVE.
 DOWNERS GROVE, IL 60515

TECHNOLOGY PLAN - AREA C

Project Number:
 220281
 Drawn By:
 -
 Sheet:



T1.2

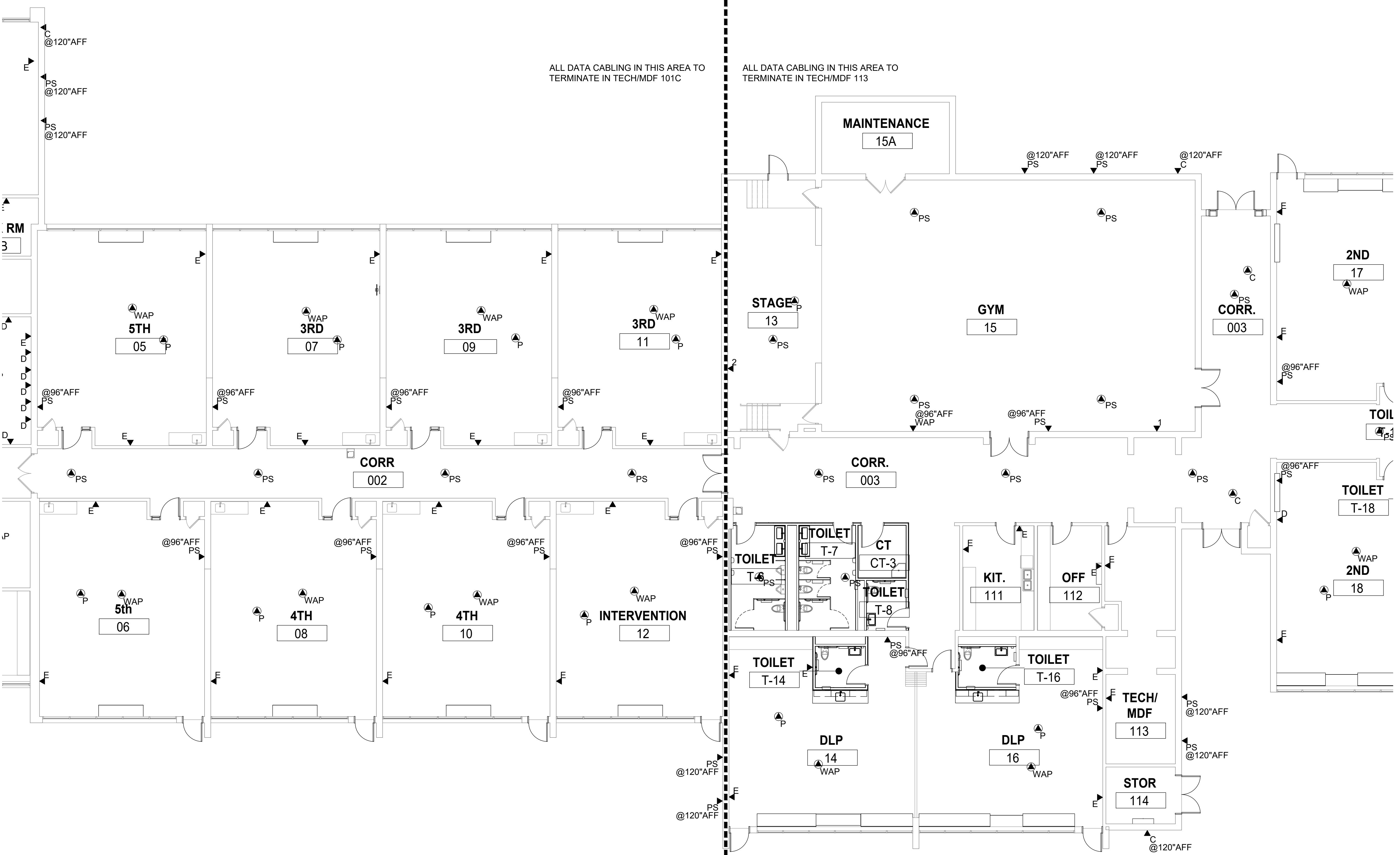

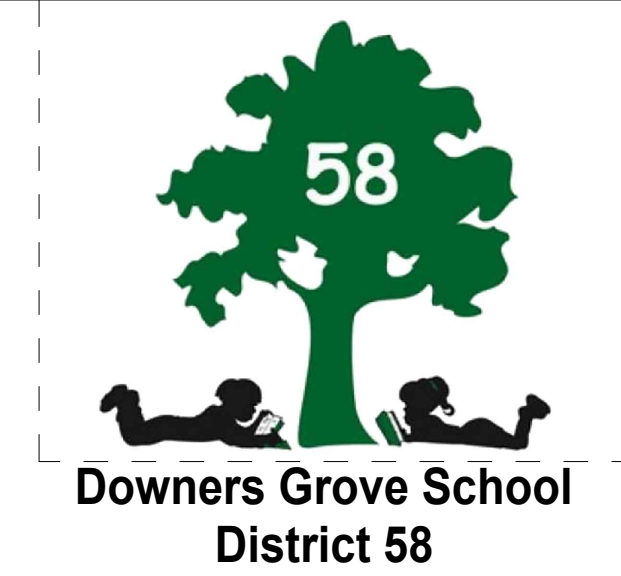

Wight

Wight & Company
 wightco.com
 2500 North Frontage Road
 Darien, IL 60561
 P 630.969.7000
 F 630.969.7979

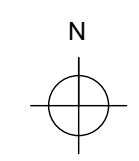
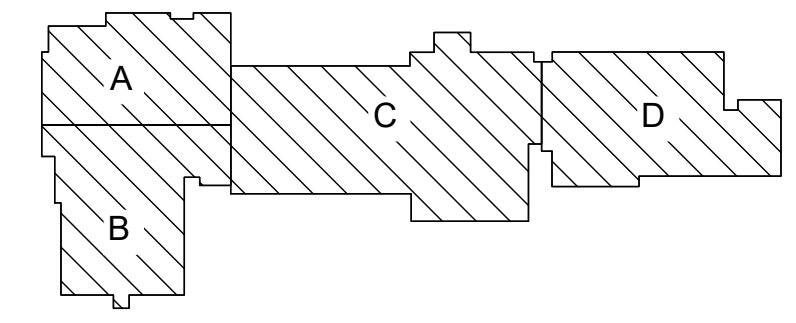

NOT FOR CONSTRUCTION

REV	E-RATE RFP DESCRIPTION	12/18/2023 DATE
-----	------------------------	-----------------

HILLCREST ELEMENTARY SCHOOL

1435 JEFFERSON AVE.
 DOWNERS GROVE, IL 60515
TECHNOLOGY PLAN - AREA D

Project Number:
 220281
 Drawn By:
 -
 Sheet:



T1.3

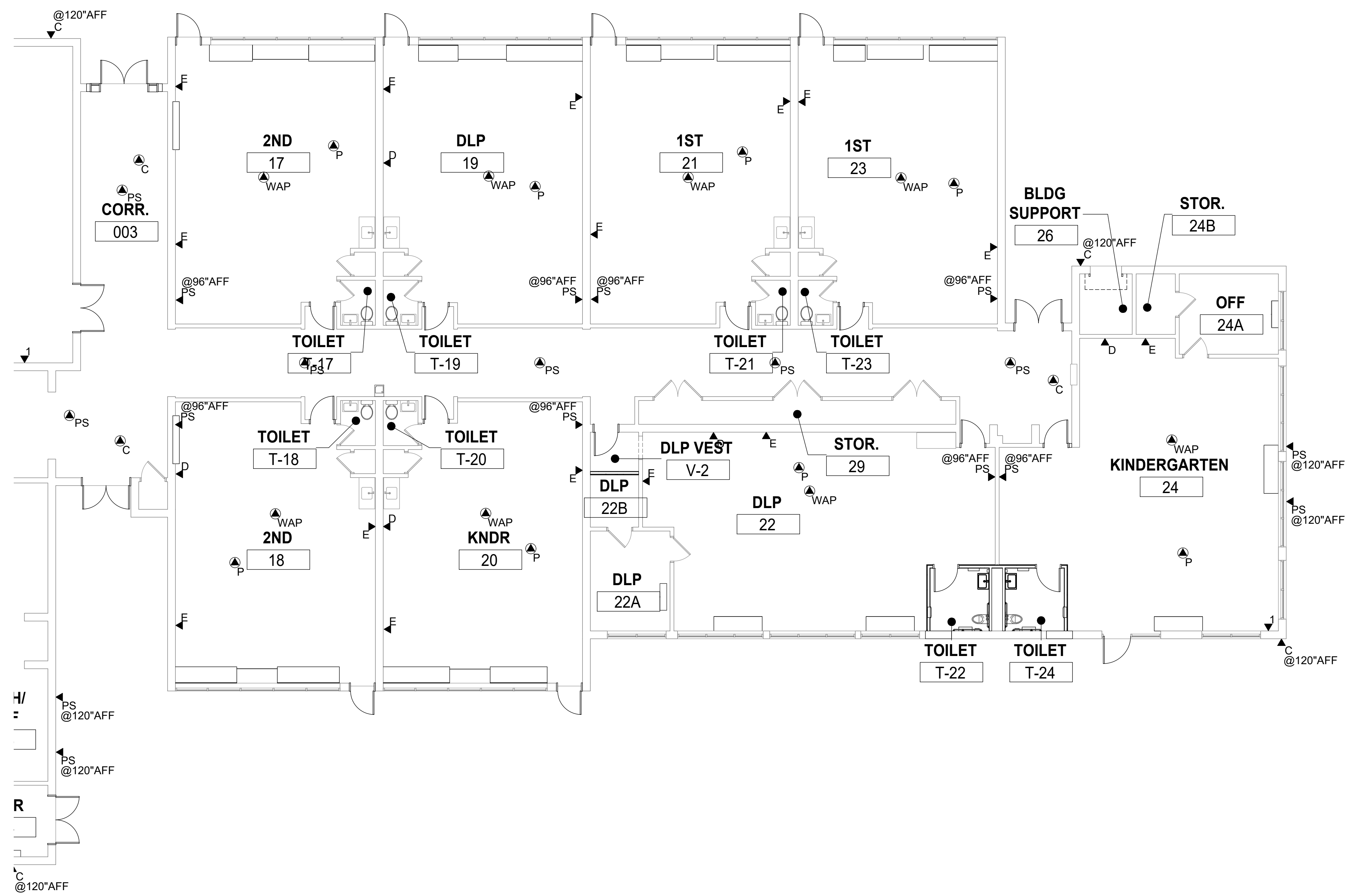

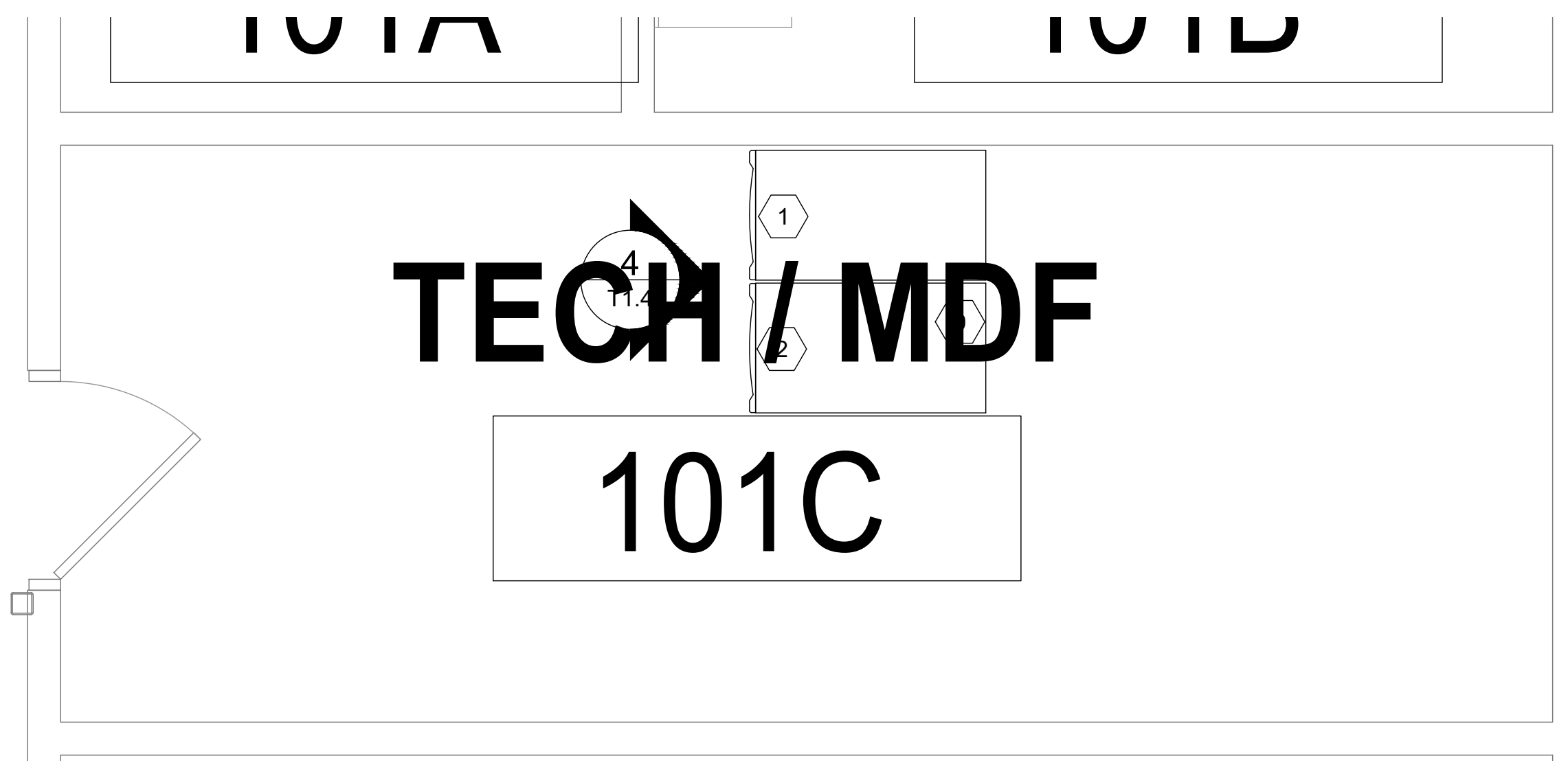

1 CABINET LAYOUT - TECH/MDF 101C
PLAN VIEW
1/2" = 1' - 0"

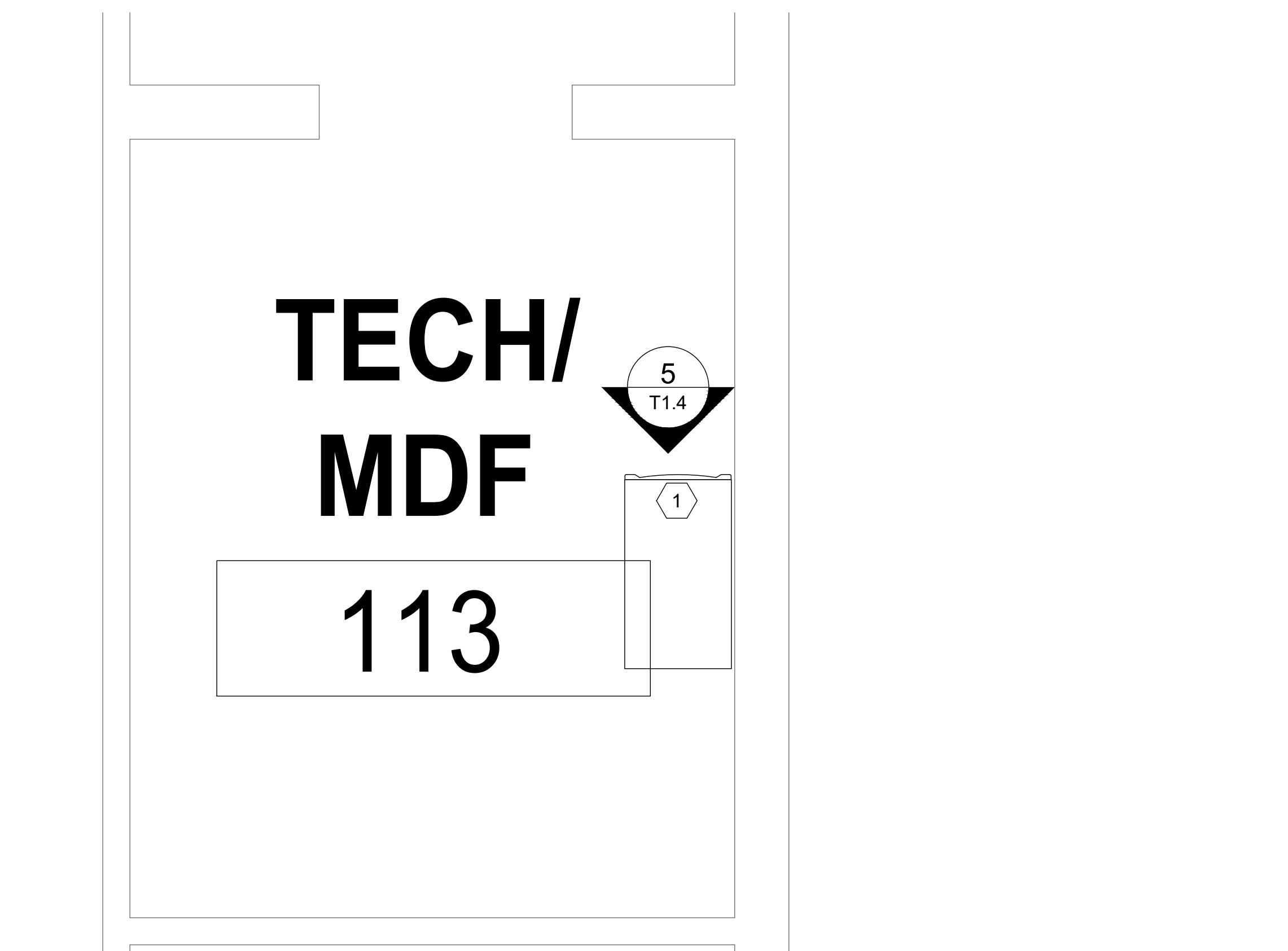

2 CABINET LAYOUT - TECH/MDF 113
PLAN VIEW
1/2" = 1' - 0"

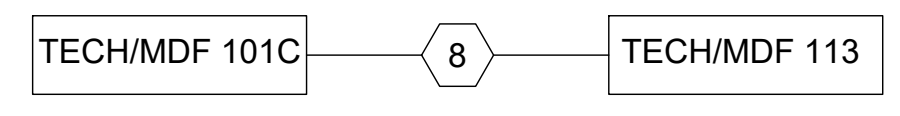

3 BACKBONE CABLING REQUIREMENTS
SCHEMATIC VIEW
NOT TO SCALE

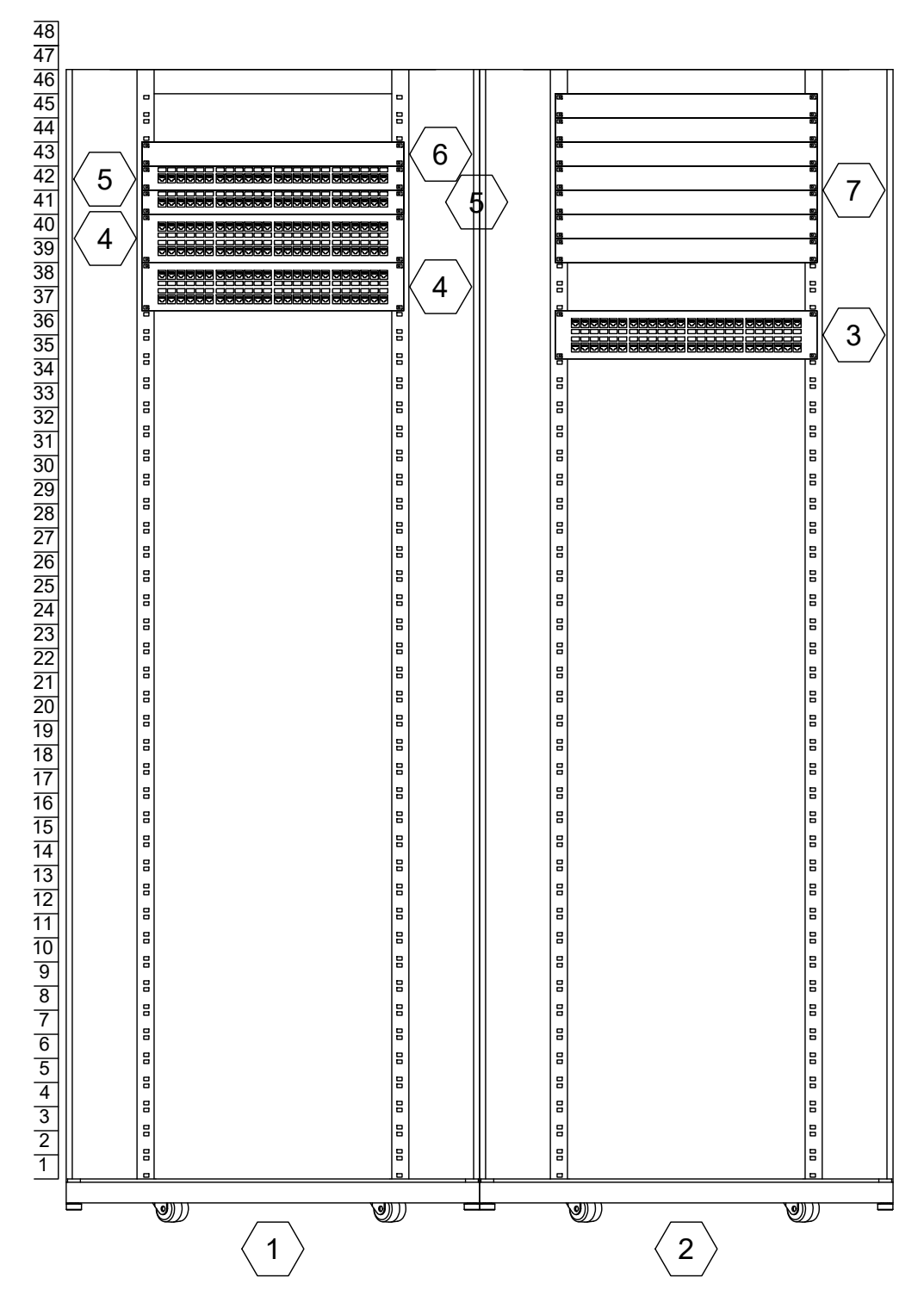

4 CABINET LAYOUT - TECH/MDF 101C
ELEVATION VIEW - FRONT
1" = 1' - 0"

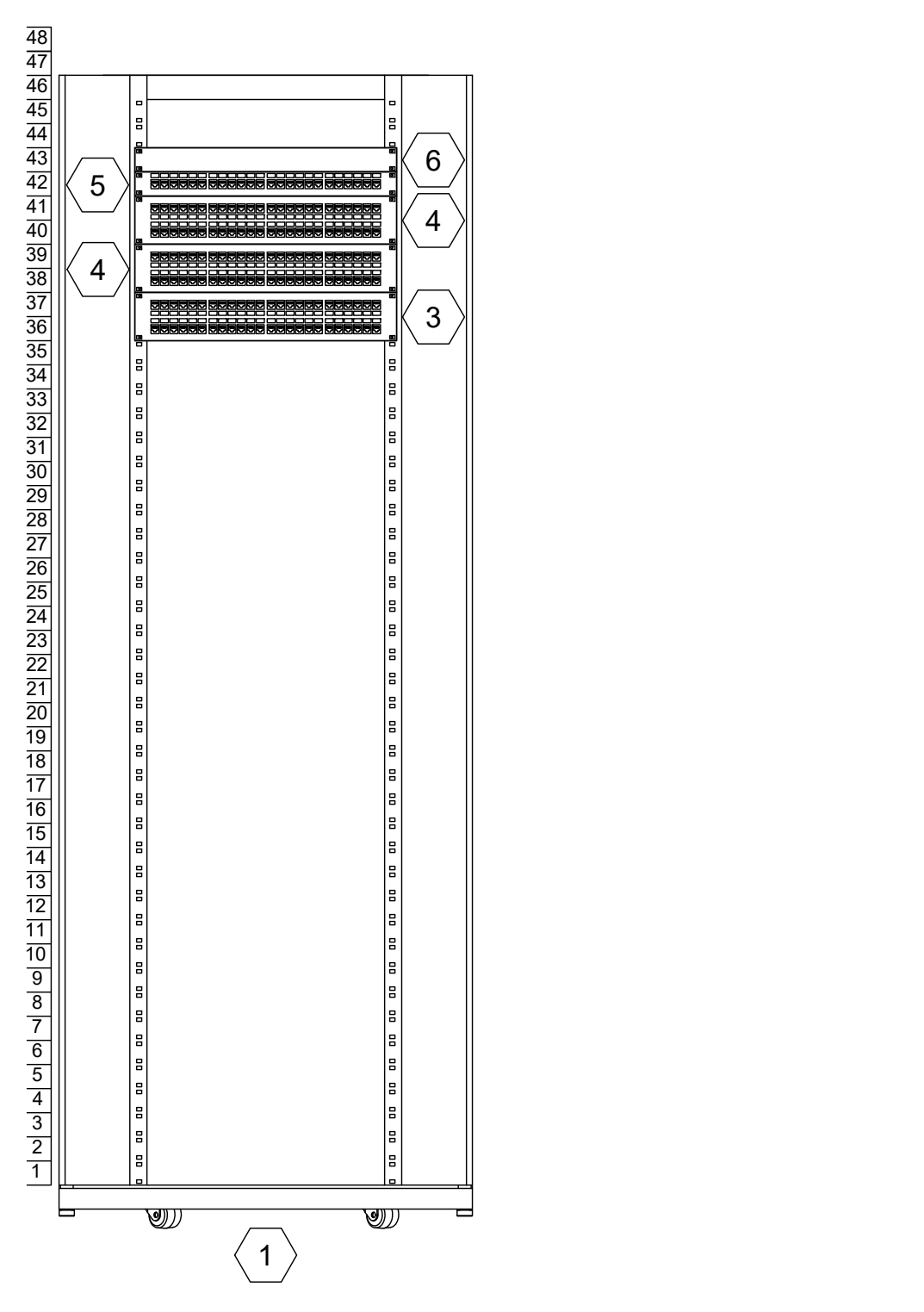

5 CABINET LAYOUT - TECH/MDF 113
ELEVATION VIEW - FRONT
1" = 1' - 0"

DRAWING KEYNOTES:

- 1 EXISTING TO REMAIN ENCLOSED EQUIPMENT CABINET.
- 2 CIC SUPPLIED AND INSTALLED ENCLOSED EQUIPMENT CABINET TO HOUSE THE PAGING SYSTEM COMPONENTS. CIC TO REMOVE EXISTING 2-POST RACK TO ALLOW FOR THE INSTALLATION OF THE PAGING CABINET.
- 3 CIC SUPPLIED AND INSTALLED CATEGORY 6 2U 48-PORT PATCH PANEL TO SUPPORT TERMINATION OF HORIZONTAL STATION CABLING FOR PAGING SYSTEM COMPONENTS. REFER TO SPECIFICATION FOR EXACT REQUIREMENTS.
- 4 CIC SUPPLIED AND INSTALLED CATEGORY 6 2U 48-PORT PATCH PANEL TO SUPPORT TERMINATION OF HORIZONTAL STATION CABLING. REFER TO SPECIFICATION FOR EXACT REQUIREMENTS.
- 5 CIC SUPPLIED AND INSTALLED CATEGORY 6A 1U 24-PORT PATCH PANEL TO SUPPORT WIRELESS ACCESS POINT CABLING CONNECTIVITY REQUIREMENTS. REFER TO SPECIFICATION FOR EXACT REQUIREMENTS.
- 6 CIC SUPPLIED AND INSTALLED 1U FIBER OPTIC TERMINATION SHELF TO SUPPORT TERMINATION OF FIBER BACKBONE CABLING. REFER TO SPECIFICATION FOR EXACT REQUIREMENTS.
- 7 CIC SUPPLIED AND INSTALLED PAGING SYSTEM COMPONENTS. REFER TO PAGING SYSTEM DETAILS DRAWING FOR EXACT REQUIREMENTS.
- 8 LOW VOLTAGE INTEGRATOR SUPPLIED AND INSTALLED QUANTITY ONE (1) 24-STRAND 50-MICRON OM4 GRADE ARMORED FIBER OPTIC CABLE. REFER TO CABLE SPECIFICATION DRAWING FOR EXACT REQUIREMENTS.
- 9 EC FURNISHED AND INSTALLED NEMA 5-20 QUAD RECEPTACLE MOUNTED IN THE REAR OF THE CABINET AT THE TOP. REFER TO E-SERIES DRAWINGS FOR EXACT REQUIREMENTS.

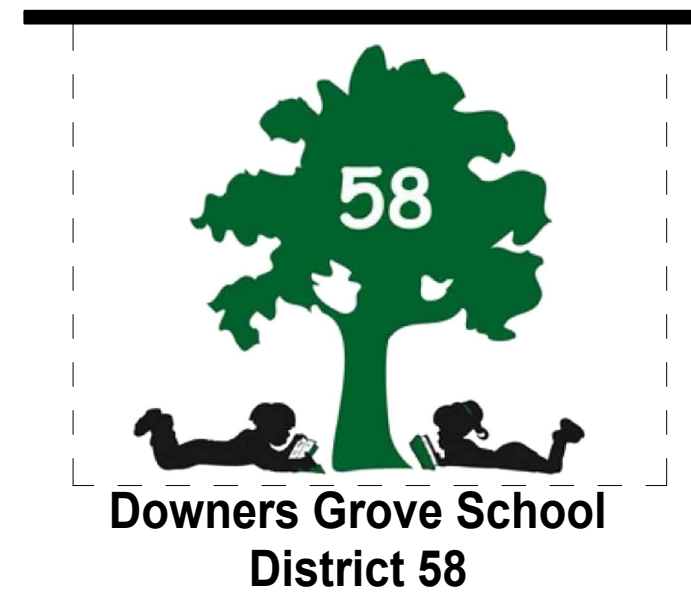

Wight & Company
wightco.com
2500 North Frontage Road
Darien, IL 60561
P 630.969.7000
F 630.969.7979

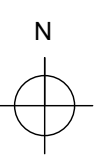
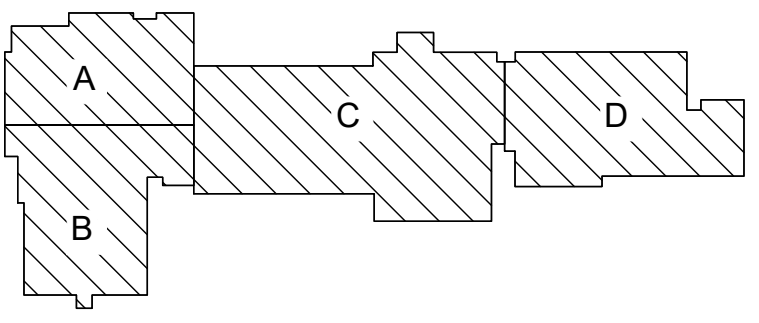

NOT FOR CONSTRUCTION

REV	E-RATE RFP DESCRIPTION	12/18/2023 DATE

HILLCREST ELEMENTARY SCHOOL

1435 JEFFERSON AVE.
DOWNERS GROVE, IL 60515

TECH/MDF ROOM LAYOUTS



Project Number:
220281
Drawn By:
-
Sheet:



T1.4

Whittier Elementary School - D58 Referendum Improvements

Downers Grove School District 58

536 Hill St.

Downers Grove, IL 60515

220281

December 18, 2023

ISSUED FOR E-RATE RFP

NOT FOR CONSTRUCTION

PROJECT TEAM		DRAWING SHEET INDEX		LOCATION
<p>CLIENT DOWNERS GROVE GRADE SCHOOL DISTRICT 58 2300 WARRENVILLE RD, SUITE 200 NE DOWNERS GROVE, IL 60516 PHONE: (630)719-5859 CONTACT: KEVIN BARTO</p> <p>STRUCTURAL ENGINEER WIGHT & COMPANY 2500 NORTH FRONTAGE ROAD DARIEN, IL 60561 PHONE: (630)969-7000 FAX: (630)969-7979 CONTACT: MATT AQUINO Design Firm Registration #184-000451</p> <p>TECHNOLOGY SERVICES SENTINEL TECHNOLOGIES 2550 WARRENVILLE RD. DOWNERS GROVE, IL 60515 PHONE: (630) 769-4284 CONTACT: FRANK KRISTOFF</p>	<p>ARCHITECT WIGHT & COMPANY 2500 NORTH FRONTAGE ROAD DARIEN, IL 60561 PHONE: (630)969-7000 FAX: (630)969-7979 CONTACT: AMY TIBERI Design Firm Registration #184-000451</p> <p>PLUMBING & FIRE PROTECTION ENGINEER WIGHT & COMPANY 2500 NORTH FRONTAGE ROAD DARIEN, IL 60561 PHONE: (630)969-7000 FAX: (630)969-7979 CONTACT: BILL BAUER Design Firm Registration #184-000451</p> <p>MECHANICAL ENGINEER WIGHT & COMPANY 2500 NORTH FRONTAGE ROAD DARIEN, IL 60561 PHONE: (630)969-7000 FAX: (630)969-7979 CONTACT: SUDESH SARAF Design Firm Registration #184-000451</p> <p>ELECTRICAL ENGINEER WIGHT & COMPANY 2500 NORTH FRONTAGE ROAD DARIEN, IL 60561 PHONE: (630)969-7000 FAX: (630)969-7979 CONTACT: ANTHONY SULLENTRUP Design Firm Registration #184-000451</p>	<p>BUILDING CODE DATA</p> <p>1. APPLICABLE CODES BUILDING CODE: 2015 INTERNATIONAL EXISTING BUILDING CODE MECHANICAL CODE: 2015 INTERNATIONAL MECHANICAL CODE ELECTRICAL CODE: 2014 NATIONAL ELECTRICAL CODE PLUMBING CODE: ILLINOIS PLUMBING CODE - CURRENT EDITION ACCESSIBILITY CODE: 2018 ILLINOIS ACCESSIBILITY CODE ENERGY CODE: 2018 INTERNATIONAL ENERGY CONSERVATION FIRE CODE: 2015 INTERNATIONAL FIRE CODE OTHER CODES: 2015 IBC FUEL GAS CODE</p> <p>2. GENERAL BUILDING DESCRIPTION GROSS BUILDING AREA, EXISTING: 37,435 SF GROSS BUILDING AREA, TOTAL (NEW & EXISTING): 37,435 SF</p> <p>3. BUILDING OCCUPANCY TYPE SECTION 302 OCCUPANCY CLASSIFICATION: E</p> <p>4. CONSTRUCTION TYPE SECTION 503, 602 CONSTRUCTION TYPE: IIB, IV FIRE RESISTANCE RATING REQUIREMENTS: TABLE 601 STRUCTURAL FRAME: 0 HR BEARING WALLS (EXTERIOR) (ALSO SEE TABLE 602): 0 HR BEARING WALLS (INTERIOR): 0 HR NON-BEARING WALLS (EXTERIOR): SEE TABLE 602 NON-BEARING WALLS (INTERIOR): 0 HR FLOOR CONSTRUCTION: 0 HR ROOF CONSTRUCTION: 0 HR EXTERIOR WALL FIRE SEPARATION DISTANCE: TABLE 602 LESS THAN 5': 1 HR LESS THAN OR EQUAL TO 5' TO LESS THAN 10': 1 HR LESS THAN OR EQUAL TO 10' TO LESS THAN 30': 0 HR GREATER THAN OR EQUAL TO 30': 0 HR</p> <p>ADDITIONAL CODE IEBC CHAPTER 4 PRESCRIPTIVE COMPLIANCE PATH DICTATE WHERE FIRE RATING WILL BE REQUIRED COMMON PATH OF EGRESS - 75 FEET MAX. MAX TRAVEL DISTANCE - 200 FEET</p>	<p>GENERAL G0.00 G0.02</p> <p>TECHNOLOGY T0.0 T1.0 T1.1 T1.2</p> <p>COVER SHEET GENERAL INFORMATION, SYMBOLS, NOTES & ABBREVIATIONS</p> <p>LEGEND AND GENERAL NOTES TECHNOLOGY PLAN - AREA A TECHNOLOGY PLAN - AREA B TECH/MDF 34 LAYOUT</p>	

ILLINOIS ENERGY CONSERVATION CODE STATEMENT OF COMPLIANCE

I HAVE PREPARED OR CAUSED TO BE PREPARED UNDER MY DIRECT SUPERVISION, THE ATTACHED PLANS AND SPECIFICATIONS AND STATE THAT, TO THE BEST OF MY KNOWLEDGE AND BELIEF AND TO THE EXTENT OF MY CONTRACTUAL OBLIGATION, THEY ARE IN COMPLIANCE WITH THE REQUIREMENTS OF THE 2015 ILLINOIS ENERGY CONSERVATION CODE

SIGNED: _____

ILLINOIS REGISTRATION NO.: _____

DATE: _____

ARCHITECT

SEAL & SIGNATURE APPLY TO GENERAL AND ARCHITECTURAL SHEETS INDICATED ON G0.01 SHEET AS G, A-SERIES, AND INCLUDED IN THE PERMIT DOCUMENTS.

SIGNED: _____

ILLINOIS REGISTRATION NO.: _____

DATE: _____

STATEMENT OF COMPLIANCE

I HAVE PREPARED OR CAUSED TO BE PREPARED UNDER MY DIRECT SUPERVISION, THE ATTACHED PLANS AND SPECIFICATIONS AND STATE THAT, TO THE BEST OF MY KNOWLEDGE AND BELIEF AND TO THE EXTENT OF MY CONTRACTUAL OBLIGATION, THEY ARE IN COMPLIANCE WITH THE ENVIRONMENTAL BARRIERS ACT (IL. REV. STAT. 1985, CH. 111 1/2, PARS. 3711 ET SEQ AS AMENDED) AND THE ILLINOIS ACCESSIBILITY CODE, 71 IL ADM. CODE 400.

SIGNED: _____

ARCHITECT/ENGINEER

ILLINOIS REGISTRATION NO.: _____

DATE: _____

FOR UNDERGROUND UTILITY LOCATIONS, CALL J.U.L.I.E.

TOLL FREE TEL. 1-800-892-0123
JULIE SUBURBS & DIGG CHICAGO

- YELLOW _____ GAS
- RED _____ ELECTRICAL
- ORANGE _____ PHONE / TV COMMUNICATION
- BLUE _____ WATER
- GREEN _____ SEWERS
- WHITE _____ SAFE TO DIG

TYPICAL FIXTURE MOUNTING HEIGHTS, U.N.O.

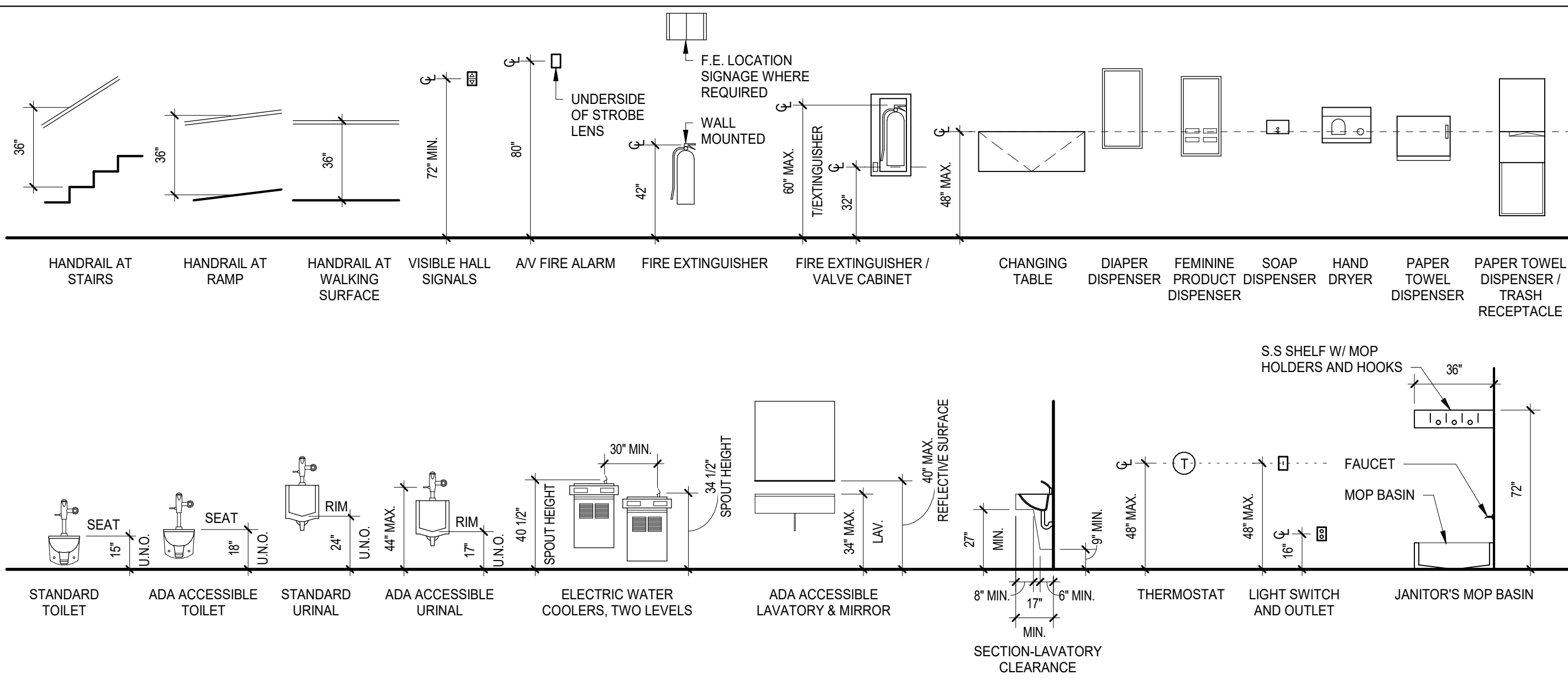

FIRESTOP SYSTEM MATRIX

- NOTES:
 1. UL TEST DESIGNATION SHOWN ARE FOR GUIDANCE ONLY. CONTRACTOR SHALL PROVIDE SUBMITTALS FOR EACH BASED ON ACTUAL FIELD CONDITIONS.
 2. REFER TO THE UL THROUGH PENETRATION GUIDELINES FOR ADDITIONAL USE OF SYSTEMS.
 3. CONTRACTOR SHALL COORDINATE THE ALLOWED MOVEMENT OF A FIRESTOP SYSTEM WITH THE STRUCTURAL ENGINEERS ANTICIPATED SLAB MOVEMENT.
 4. IF ANY DEVIATIONS OCCUR FROM THE SYSTEMS SHOWN, THE CONTRACTOR SHALL SUBMIT AN ALTERNATE UL TESTED SYSTEM OR MANUFACTURER'S ENGINEERING JUDGMENT.
 5. ALL EXISTING CORRIDOR WALLS ARE 1 HOUR RATED. PROVIDE FIRE STOPPING AS APPLICABLE.

DESCRIPTION	CONCRETE FLOOR OR BLOCK WALLS	GYPSUM WALLS	GYPSUM SHAFT WALLS
BLANK OPENING	CAJ-0090 FA-0014	WL-0012 WL-0040	
METAL PIPE	CAJ-1226 FA-1016	WL-1054 WL-1297	WL-1205 WL-1380
PLASTIC PIPE	CAJ-2109 FA-2054	WL-2078 WL-2128	
INSULATED PLASTIC PIPE	CAJ-5320	WL-5225	
CABLE BUNDLE	CAJ-3095 FA-3007	WL-3065 WL-3334 WL-3384	WL-3161
CABLE TRAYS	CAJ-4071 CAJ-4083	WL-4011	
METAL PIPE WITH GLASS FIBER OR POLYISO INSUL.	FA-5032 CAJ-5091 FA-5017	WL-5029 WL-5257	WL-5244
METAL PIPE WITH AB/PVC INSUL.	CAJ-5090 FA-5032 FA-5015	WL-5028 WL-5257	WL-5143
MISC. ELECTRICAL/BUSWAY	CAJ-8017 CAJ-8042	WL-6019	
SHEET METAL DUCT/ RECTANGULAR	CAJ-7051	WL-7040 WL-7155 WL-7059	
SHEET METAL DUCT/ ROUND	CAJ-7084	WL-7042 WL-7153	WL-7068
MULTIPLE PENETRATIONS	CAJ-8143 FA-8012 FA-5032	WL-8065 WL-8079 WL-8071	WL-8098

ABBREVIATIONS

- ACCESS. ACCESSIBLE
 AC. AMERICAN CONCRETE INSTITUTE
 ACoust. ACOUSTICAL
 ACT ACOUSTICAL CEILING TILE
 ADA AMERICANS WITH DISABILITIES ACT
 A.F.F. ABOVE FINISHED FLOOR
 ALT. ALTERNATE
 ALUM./AL. ALUMINUM
 APPROX. APPROXIMATE
 ARCH. ARCHITECTURAL
 ASTM. AMERICAN SOCIETY FOR TESTING AND MATERIALS
 @ AT
 AV AUDIO VISUAL BOARD
 BLDG. BUILDING
 BM BEAM
 B/O BOTTOM OF
 BRK. BREAK
 CAB. CABINET
 CC CENTER TO CENTER
 C CENTERLINE
 CJ CONTROL JOINT
 CMU CONCRETE MASONRY UNITS
 COL. COLUMN
 CLG. CEILING
 CLR. CLEAR
 CONC. CONCRETE
 CONT. CONTINUOUS
 CONTR. CONTRACTOR
 CORR. CORRIDOR
 CPT. CARPET
 CR. ACCESS CARD READER
 CT. CERAMIC TILE
 DIA. DIAMETER
 DIMS. DIMENSIONS
 DN. DOWN
 DR. DOWN SPOUT
 DS. DRAWING
 DWGS. DRAWINGS
 EA. EACH
 EIFS EXTERIOR INSULATED FINISH SYSTEM
 EL. ELEVATION
 ELEC. ELECTRICAL
 ELEV. ELEVATOR
 E.J. EXPANSION JOINT
 EQ. EQUAL
 EQUIP. EQUIPMENT
 EWC ELECTRIC WATER COOLER
 EXP. EXPANSION
 EXT. EXTERIOR
 EXIST. EXISTING
 ETR. EXISTING TO REMAIN
 FD. FLOOR DRAIN
 FE. FIRE EXTINGUISHER CABINET
 FF. FINISH
 FL.FLR. FLOOR
 FOUND. FOUNDATION
 FT. FOOT/FEET
 FTG. FOOTING
 GA. GAUGE
 GALV. GALVANIZED
 GWB/ GYP. BD. GYPSUM WALL BOARD
 HD. HEAVY DUTY
 HM. HOLLOW METAL
 HOR. HORIZONTAL
 HP. HIGH POINT
 HT/HTG. HEIGHT
 HVAC. HEATING, VENTILATION & AIR CONDITIONING
 IN. INCH
 INSUL. INSULATED/INSULATION
 INT. INTERIOR
 JT. JOINT
 LAV. LAVATORY
 LINO. LINOLEUM
 LBS. POUNDS
 LP. LOW POINT
 LVL. LEVEL
 M. MENS
 MAT. MATERIAL
 MAX. MAXIMUM
- MAS. MASONRY MANUFACTURER
 MFR./MAN UF./MANF. MFG.
 MD. MEDIUM DENSITY FIBERBOARD
 MIL. MILLIMETERS
 MIN. MINIMUM
 MISC. MISCELLANEOUS
 MHO. MAGNETIC HOLD OPEN
 M.O. MASONRY OPENING
 MTL. METALS
 NEG. NOT IN CONTRACT
 N.I.C. NUMBER
 NTS. NOT TO SCALE
 ON CENTER
 O.C. OUTSIDE DIAMETER
 ORD. OVERFLOW ROOF DRAIN
 P.B. PIPE BOLLARD
 PERS. PERSON
 PL. PLATE
 PL./P LAM. PLASTIC LAMINATE
 PLY. PLYWOOD
 PP. CENTERLINE
 P. PLATE
 R. RADIUS
 PSF. POUNDS PER SQUARE FOOT
 PSI. POUNDS PER SQUARE INCH (PAINTED)
 P/PTD. PRESSURE TREATED
 P.T. PLYWOOD
 RAD. RADIUS
 RCP. REFLECTED CEILING PLAN
 RD. ROOF DRAIN
 RESTRM. RESTROOM
 RM. ROOM
 R.O. ROUGH OPENING
 RTU. ROOF TOP UNIT
 SAFB. SOUND ATTENUATION FIBER BATT INSULATION
 SC. SEALED CONCRETE SCHEDULE
 SCHD./SC SCHEDULE
 HED. HEDGING
 SD. SQUARE FEET
 SF. STRUCTURAL GLAZED FACING TILE
 SGT. SHEET
 SIM. SIMILAR
 SI. STEEL JOINT INSTITUTE
 S.J. SHEET METAL
 S.M. SPACES
 SPA. SPECIFICATIONS
 ST. STONE TILE
 STC. SOUND TRANSMISSION COEFFICIENT
 STB. STONE TILE BASE
 ST. STEEL
 STL. STEEL ANGLE
 STL/SS. STAINLESS STEEL STORAGE
 STOR. STRUCTURAL SHEET VINYL
 SV. SYNTHETIC TOP OF
 T/ T/OFF. TOP OF FOOTING
 TPNT. TEXTURED PAINT
 TYP. TYPICAL
 UNO. UNLESS NOTED OTHERWISE
 USGS. UNITED STATES GEOLOGICAL SURVEY
 VB. VINYL BASE
 VCT. VINYL COMPOSITION TILE
 VERT. VERTICAL
 V.I.F. VERIFY IN FIELD
 VWC. VINYL WALL COVERING
 WC. WATER CLOSET
 WD. WOOD
 W. WOMENS
 W. WITH
 W/O. WITHOUT
 WWF. WELDED WIRE FABRIC

TOP OF WALL JOINTS

DESCRIPTION	CONCRETE BLOCK WALLS	GYPSUM WALLS	EXTERIOR WALL
PERP. TO METAL DECK	HWD-0042 HWD-1066/1067 HWD-0045	HWD-1037 HWD-0081	
PARALLEL TO METAL DECK	HWD-0049 HWD-1067 HWD-0184 HWD-0339	HWD-0181 HWD-0081	
PARALLEL TO STEEL BEAM	HWD-0259		
FLAT CONCRETE	HWD-1068 HWD-0208	HWD-1058 HWD-0268	
CUT TO PROFILE	HW-0324		
SHAFT WALL PARALLEL TO DECK	HWD-0570		
SHAFT WALL PERP. TO DECK	HWD-0569		
SHAFT WALL TO FLAT CONCRETE	HWD-0342 HWD-0572		

GENERAL NOTES

- WORK, MATERIALS AND METHODS SHALL BE IN CONFORMANCE WITH THE CODES, ORDINANCES AND REGULATIONS OF GOVERNMENTAL AGENCIES HAVING JURISDICTION AT THE PROJECT LOCATION.
- UNLESS OTHERWISE INDICATED IN THE CONSTRUCTION DOCUMENTS AS BEING NOT IN CONTRACT (N.I.C.) OR EXISTING, ITEMS, MATERIALS AND INSTALLATION OF SAME ARE PART OF THE CONTRACT AS DEFINED BY THE CONSTRUCTION DOCUMENTS. THE CONTRACTORS SHALL PROVIDE AND INSTALL ACCESSORIES, COMPONENTS AND ASSEMBLIES REQUIRED FOR THE WORK DEPICTED OR SPECIFIED.
- EACH CONTRACTOR SHALL BE RESPONSIBLE FOR VERIFYING DIMENSIONS AND EXISTING CONDITIONS BEFORE COMMENCING WORK. REPORT DISCREPANCIES AND/OR POTENTIAL PROBLEMS PRIOR TO PROCEEDING WITH AFFECTED WORK.
- FIRE-RATED ASSEMBLIES SHALL BE INSTALLED, LABELED, AND INSPECTED IN ACCORDANCE WITH THE APPLICABLE CODES. THIS INCLUDES FIRE DAMPERS OR FIRE DOORS PROVIDED WHERE AIR DUCTS OR OPENINGS PENETRATE FIRE RATED SURFACES. PENETRATIONS OF RATED FIRE RESISTIVE CONSTRUCTION SHALL BE PROTECTED WITH APPROVED FIRE ASSEMBLIES.
- PENETRATIONS THROUGH SURFACE SHALL BE SEALED WITH SEALANT MATERIAL PER SPECIFICATIONS. FOR PLUMBING, FIRE SPRINKLER AND ELECTRICAL SYSTEMS.
- IN THE EVENT OF DISCREPANCIES BETWEEN DRAWINGS AND/OR SPECIFICATIONS, THE MORE COSTLY OR MORE RESTRICTIVE CONDITIONS SHALL BE DEEMED THE CONTRACT REQUIREMENT UNLESS OTHERWISE STATED IN WRITING.
- PROVIDE GALVANIC PROTECTION BETWEEN DISSIMILAR MATERIALS, WHERE REQUIRED.
- KEEP PIPING AS CLOSE TO WALLS AS POSSIBLE UNLESS NOTED OTHERWISE.
- NO CONTRACTORS SHALL CLOSE OR OBSTRUCT STREETS, DOCKS, ALLEYS OR WALKS. NO MATERIALS ARE TO BE PLACED OR STORED IN STREETS, ALLEYS OR WALKS. DEBRIS IS TO BE REMOVED COMPLETELY FROM THE PREMISES.
- CONTRACTORS SHALL PROVIDE AND ARE SOLELY RESPONSIBLE AND LIABLE FOR PUBLIC AND EMPLOYEE PROTECTION AS NECESSARY AND AS REQUIRED BY THE CODES, INCLUDING EXTERIOR, INTERIOR PEDESTRIAN AND TRAFFIC BARRIERS. EXISTING EXIT CORRIDORS, PATHS OF EXITS, STAIRWAYS, OR EXIT SIGNAGE, MUST HAVE A CLEAR MEANS OF EGRESS DURING PHASES OF CONSTRUCTION.
- CONTRACTORS WISHING TO WORK IN THE BUILDING OR ON THE BUILDING PROPERTY SHALL BE REQUIRED TO PRESENT THE PROPER CERTIFICATES OF INSURANCE. CONTRACTORS ARE REQUIRED TO BE LICENSED WITH THE LOCAL JURISDICTION. LICENSES AND BONDING ARE TO BE INCLUDED IN THE BID PER THE REQUIREMENTS IN THE SPECIFICATIONS.
- DIMENSIONS NOTED ON THE ARCHITECTURAL FLOOR PLAN REGARDING DETAILS AND PARTITION THICKNESSES ARE NOMINAL DIMENSIONS. REFER TO A8 SERIES FOR THE EXACT DIMENSION.

GRAPHIC SYMBOLS

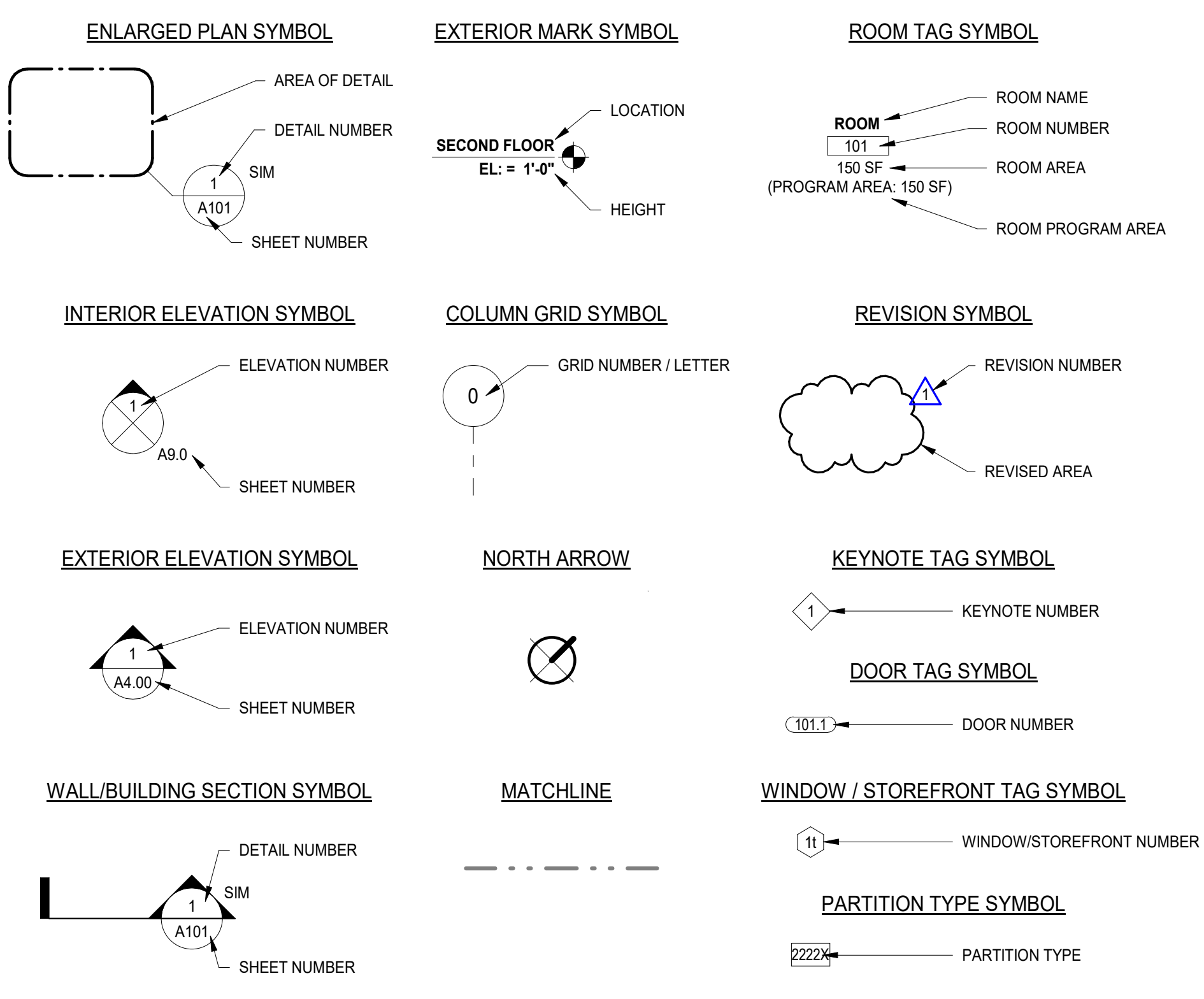

MATERIAL LEGEND

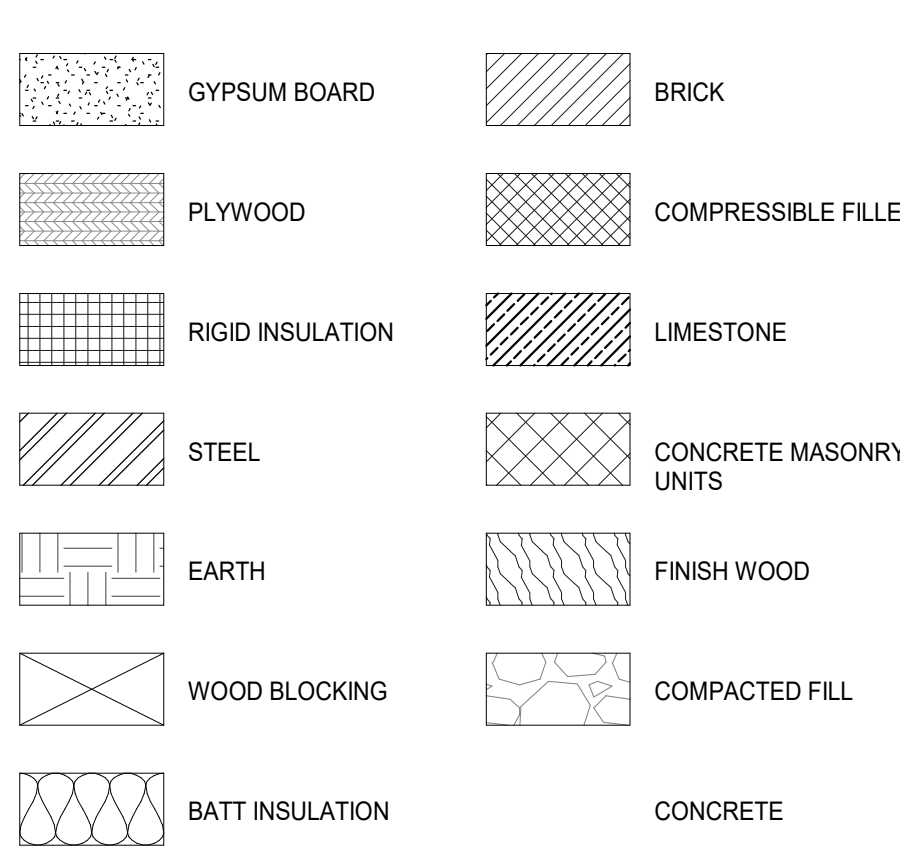

FURNISHED AND INSTALLED MATRIX.

D58 Equipment Matrix Henry Puffer

TOILET ROOM ACCESSORIES	FURNISHED BY	INSTALLED BY
PAPER TOWEL HOLDER	TOILET ROOMS	OWNER CONTRACTOR
SOAP DISPENSERS	TOILET ROOMS	OWNER CONTRACTOR
TOILET PAPER HOLDERS	TOILET ROOMS	OWNER CONTRACTOR
ALL OTHER ACCESSORIES	TOILET ROOMS	CONTRACTOR CONTRACTOR



Wight

Wight & Company
 wightco.com
 2500 North Frontage Road
 Darien, IL 60561
 P 630.969.7700
 F 630.969.7979

NOT FOR CONSTRUCTION

TYPICAL DOOR LOCATION

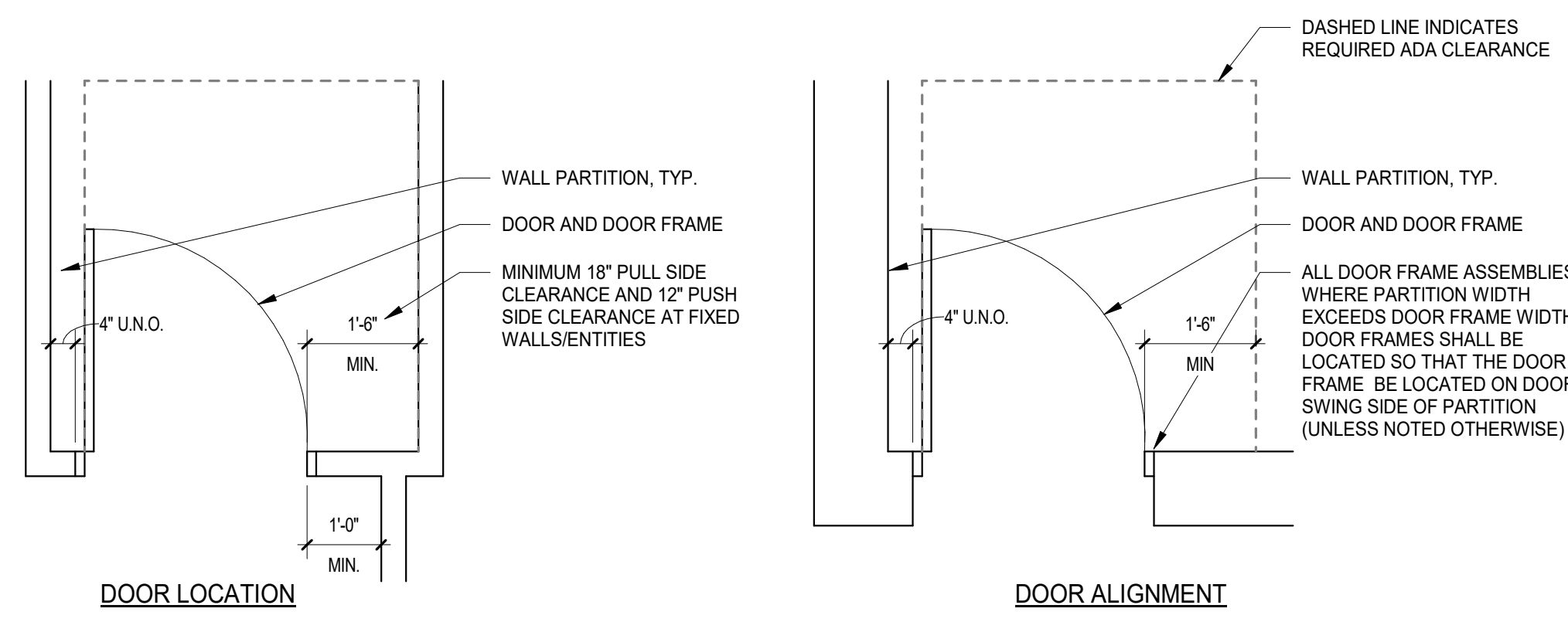

ADA ACCESSIBLE TOILET PLAN & ELEVATIONS

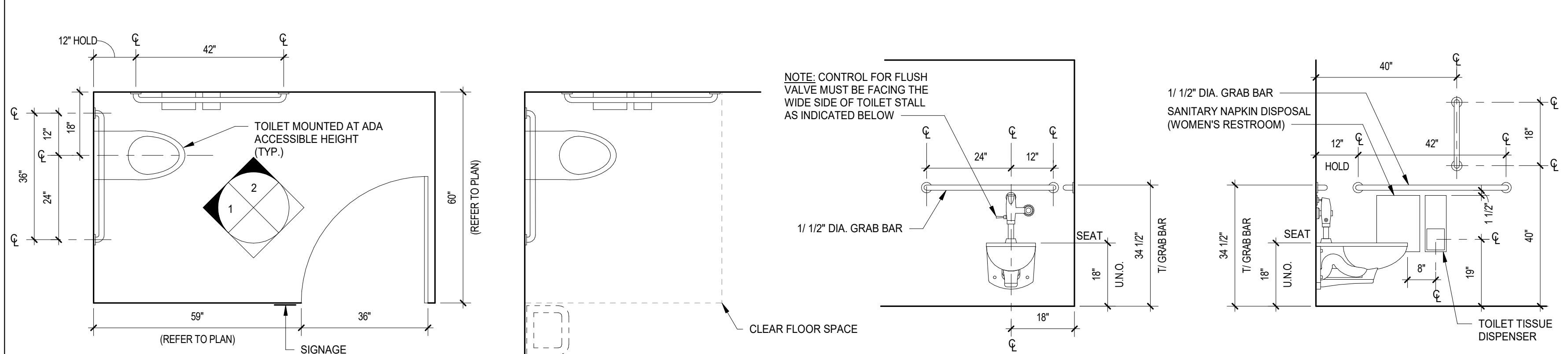

12/12/2023 10:14:49 AM
 Autodesk Docs/058 EHS Phase 1 220281_Whittier_ARCH_2023.rvt
 Wight & Co. © Copyright 2016 All rights reserved. No part of these documents may be reproduced, stored, or transmitted in any form or by any means, electronic, mechanical, photocopying, recording or otherwise, without the prior written consent of Wight & Co.

E-RATE RFP 12.18.2023
 REV DESCRIPTION DATE

Whittier Elementary School - D58 Referendum Improvements

536 Hill St.
 Downers Grove, IL 60515

GENERAL INFORMATION, SYMBOLS, NOTES & ABBREVIATIONS

Project Number: 220281
 Drawn By:
 Drawn By
 Sheet:

GO.02

COMMUNICATIONS & LOW VOLTAGE CONDUIT REQUIREMENTS:

ALL CONDUIT RUNS SHALL BE 3/4" EMT, UNLESS NOTED OTHERWISE.

ALL BOXES SHALL BE A MINIMUM OF 4-11/16" x 4-11/16" x 2-1/8" DEEP BOX WITH A SINGLE GANG TRIM RING MOUNTED FLUSH TO THE WALL SURFACE, UNLESS NOTED OTHERWISE.

ALL MOUNTING HEIGHTS ARE TO THE CENTERLINE OF THE BACKBOX UNLESS NOTED OTHERWISE.

ALL CONDUIT SHALL BE ROUTED ABOVE CEILINGS, BELOW FLOORS, OR STUBBED UP WITHIN WALLS; NO CONDUIT SHALL BE EXPOSED UNLESS APPROVED BY THE ARCHITECT.

ALL CONDUITS IN WALLS SHALL STUB UP AT LEAST 6-INCHES ABOVE THE FINISHED CEILING. ALL STUBS SHALL BE REAMED AND BUSHED AT BOTH ENDS.

ALL CONDUIT PENETRATIONS THROUGH FIRE-RATED PARTITIONS SHALL BE SEALED AS REQUIRED BY CODE. ALL BACKBOXES MOUNTED WITHIN FIRE-RATED PARTITIONS SHALL MEET THE FIRE RATING OF THE PARTITION AS REQUIRED BY CODE.

PROVIDE PULL STRINGS IN ALL CONDUIT RUNS LONGER THAN 10-FEET.

PROVIDE PULL BOXES EVERY 100 LINEAR FEET OR AFTER TWO SUCCESSIVE 90° BENDS.

ALL JUNCTION AND PULL BOXES SHALL BE FURNISHED WITH ACCOMPANYING BLANK COVER PLATE.

ALL BOXES IN EXTERIOR LOCATIONS SHALL BE WEATHERPROOF AND WATERPROOF.

INSTRUCTIONS SHOWN IN DIMENSION LINES, DETAILS, ELEVATIONS, AND PLANS (IN THIS ORDER) TAKE PRECEDENCE OVER INSTRUCTIONS SHOWN IN LEGENDS.

CONDUIT AND CABLE ROUTING SHOWN IS SCHEMATIC AND IS NOT INTENDED TO REPRESENT INSTALLATION PATHS OR DISTANCES. ACTUAL ROUTING AND BOX LOCATIONS SHALL BE FIELD-VERIFIED FOR FEASIBILITY AND COORDINATED WITH OTHER DISCIPLINES BY THE INSTALLATION CONTRACTOR.

HORIZONTAL CONDUITS INTO EACH TECHNOLOGY AREA FROM THE EXTERIOR CEILING PLENUM ARE REQUIRED FOR CABLE ACCESS INTO THE ROOM FROM ALL LOCATIONS THROUGHOUT THE SPACE. THE ENDS OF THE CONDUITS SHALL BE REAMED AND BUSHED, AND EXTEND A MINIMUM OF 2-INCHES INTO THE ROOM.

Table with 8 columns: CABLE O.D. (") and CONDUIT TRADE SIZE AND MAXIMUM QUANTITIES OF CABLES OF THAT O.D. (3/4", 1", 1-1/4", 1-1/2", 2", 3", 4").

Table with 3 columns: NUMBER AND SIZE OF CONDUITS, PULL BOX SIZE (W x L x H IN INCHES), FOR EACH ADDITIONAL CONDUIT ENTERING THE PULL BOX, INCREASE THE WIDTH.

TECHNOLOGY DRAWING INDEX - E-RATE RFP

- T0.0 - LEGEND AND GENERAL NOTES
T0.1 - TECHNOLOGY PLAN - BASEMENT AREA B
T1.0 - TECHNOLOGY PLAN - AREA A
T1.1 - TECHNOLOGY PLAN - AREA B
T1.2 - TECH/MDF 34 LAYOUT

TELECOMMUNICATIONS GROUNDING NOTES:

- 1. REFER TO E-SERIES DRAWINGS FOR PANEL SCHEDULING INFORMATION AND GROUNDING ELECTRODE SYSTEM DATA.
2. A SINGLE GROUND SOURCE SHALL BE PROVIDED FOR GROUNDING ALL RACKS, TRAYS AND METAL FRAMES IN THE MAIN DISTRIBUTION FRAME.
3. A TELECOMMUNICATIONS GROUNDING BUSBAR (TGB) SHALL BE INSTALLED IN ANY/ALL TELECOM ROOMS.
4. A GROUND CABLE FROM THE TMGB TO EACH TGB SHALL BE INSTALLED TO CREATE A FORMAL TELECOMMUNICATIONS BONDING BACKBONE (TBB).
5. THE CONTRACTOR SHALL PROVIDE AND INSTALL A MINIMUM #6 AWG GROUND WIRE FROM EACH OPEN RELAY RACK AND CABLE TRAY TO THE MAIN TELECOMMUNICATIONS GROUNDING BUSBAR OR TELECOMMUNICATIONS GROUNDING BUSBAR.
6. ANY PENETRATION THROUGH A FIRE-RATED WALL SHALL BE PROPERLY FIRE-STOPPED BY THE CONTRACTOR WITH THE APPROPRIATE FIRE-STOP MATERIAL PER APPLICABLE BUILDING AND ELECTRICAL CODES.
7. THE CONTRACTOR SHALL COORDINATE GROUND CABLE INSTALLATION WITH THE ARCHITECTS, MEP ENGINEERS AND THE OTHER TRADES ON THE PROJECT.
8. THE CONTRACTOR SHALL ASSUME RESPONSIBILITY FOR ANY DAMAGE TO ANY COMPONENT OF THE TELECOMMUNICATIONS GROUNDING SYSTEM DURNING INSTALLATION.
9. THE CONTRACTOR SHALL VERIFY THAT THE SIZE OF THE TMGB AND THE TGB ARE ADEQUATE TO SUPPORT THE TELECOMMUNICATIONS GROUNDING REQUIREMENTS FOR THE PROJECT.

Table: ANSII/TIA-607-B CONDUCTOR SIZES. Columns: LENGTH IN FEET, CONDUCTOR SIZE (AWG).

ABBREVIATIONS USED IN THESE DRAWINGS:

- AVIC = AUDIOVISUAL CABLING CONTRACTOR
CIC = CABLING INSTALLATION CONTRACTOR
EC = ELECTRICAL INSTALLATION CONTRACTOR
PIC = PAGING INSTALLATION CONTRACTOR
SIC = SECURITY INSTALLATION CONTRACTOR

NOTE: COORDINATE WITH THE ARCHITECT AND GENERAL CONTRACTOR FOR EXACT MOUNTING LOCATIONS PRIOR TO INSTALLATION OF ANY COMPONENTS.

THIS DRAWING SERIES IS INTENDED TO SHOW QUANTITIES. REFER TO A-SERIES AND E-SERIES DRAWINGS FOR EXACT LOCATIONS, HEIGHTS, AND PLACEMENT.

NOTE: THIS DRAWING SET INCORPORATES THREE-PART SPECIFICATIONS FOR INTERPRETATION; THEREFORE, THESE SPECIFICATIONS AND DRAWINGS SHALL BE TREATED AS A SINGLE ISSUANCE. IF EITHER COMPONENT IS NOT UTILIZED FOR BID, REVIEW, OR CONSTRUCTION, THEN CRITICAL INFORMATION IS MISSING THAT MAY AFFECT SCHEDULE AND PRICING. INSTALLATION CONTRACTORS SHALL TRANSMIT, DOWNLOAD, AND INCORPORATE THESE SPECIFICATIONS ALONG WITH THESE DRAWINGS.

NOTE: BASE BID WORK IS AS FOLLOWS:

- 1. BASE BID WORK SHALL INCLUDE ALL CABLING LOCATIONS IN THE HIGHLIGHTED AREAS
2. ALL CABLING LOCATIONS FOR PAGING SYSTEM, CAMERA, AND WALL DATA LOCATIONS THROUGHOUT THE ENTIRE SCHOOL

NOTE: ALTERNATE BID WORK IS AS FOLLOWS:

- 1. WIRELESS ACCESS POINT LOCATIONS THROUGHOUT THE ENTIRE SCHOOL NOT IN BASE BID AREAS
2. PROJECTOR LOCATIONS THROUGHOUT THE ENTIRE SCHOOL NOT IN BASE BID AREAS

COMMUNICATIONS LEGEND:

- ▲2 TWO (2) CABLE AND TWO (2) JACK LOCATION. CIC TO FURNISH AND INSTALL TWO (2) CATEGORY 6 CABLES AND TWO (2) CATEGORY 6 8P8C (RJ45) JACKS AT THIS LOCATION.
▲E EXISTING DATA LOCATION. CIC TO FURNISH AND INSTALL ONE (1) CATEGORY 6 CABLE AND ONE (1) CATEGORY 6 8P8C (RJ45) JACK AT THIS LOCATION.
▲D EXISTING DATA LOCATION TO BE REMOVED. CICTO FURNISH AND INSTALL A BLANK FACEPLATE AT THIS LOCATION TO COVER THE OPENING.
WAP CEILING DATA LOCATION CONSISTING OF TWO (2) CATEGORY 6A 8P8C (RJ45) JACKS AND TWO (2) CATEGORY 6 CABLES TO SUPPORT CUSTOMER PROVIDED AND CIC INSTALLED WIRELESS ACCESS POINTS.
C CEILING DATA LOCATION CONSISTING OF ONE (1) CATEGORY 6 CABLE TO SUPPORT SIC FURNISHED AND INSTALLED SURVEILLANCE CAMERA.
▲C WALL MOUNTED DATA LOCATION CONSISTING OF ONE (1) CATEGORY 6 CABLE TO SUPPORT SIC FURNISHED AND INSTALLED SURVEILLANCE CAMERA.
PCL CIC FURNISHED AND INSTALLED IP-BASED PAGING SPEAKER AND CLOCK.
CL CIC FURNISHED AND INSTALLED IP-BASED PAGING DUAL SIDED CLOCK.
PS CIC FURNISHED AND INSTALLED IP-BASED CEILING MOUNTED PAGING SPEAKER.
OPS CIC FURNISHED AND INSTALLED IP-BASED OUTDOOR PAGING SPEAKER.
ST CIC FURNISHED AND INSTALLED IP-BASED OUTDOOR STROBE.
P CEILING DATA LOCATION CONSISTING OF TWO (2) CATEGORY 6 8P8C (RJ45) JACKS AND TWO (2) CATEGORY 6 CABLES TO SUPPORT CUSTOMER PROVIDED AND INSTALLED PROJECTORS.
PS ONE (1) CABLE AND ONE (1) JACK LOCATION.
PS2 TWO (2) CABLE AND TWO (2) JACK LOCATION.
WAP TWO (2) CABLE AND TWO (2) JACK LOCATION TO SUPPORT CUSTOMER PROVIDED AND CIC INSTALLED WIRELESS ACCESS POINTS.
▲1 ONE (1) CABLE AND ONE (1) JACK LOCATION.

▲ X MOUNTING INFORMATION, WHERE X =

- A ABOVE CEILING
D TO THE DESK
F FLUSH-MOUNTED
H HIDDEN UNDER WORKSURFACE
M TO THE MULLION
R TO THE RACK ITSELF
S PLACED ON THE WORKSURFACE

AV X MOUNTING INFORMATION, WHERE X =

- A ABOVE CEILING
D TO THE DESK
F FLUSH-MOUNTED
H HIDDEN UNDER WORKSURFACE
M TO THE MULLION
P TO THE PODIUM
R TO THE RACK ITSELF
S PLACED ON THE WORKSURFACE
TX TRANSMITTER
RX RECEIVER

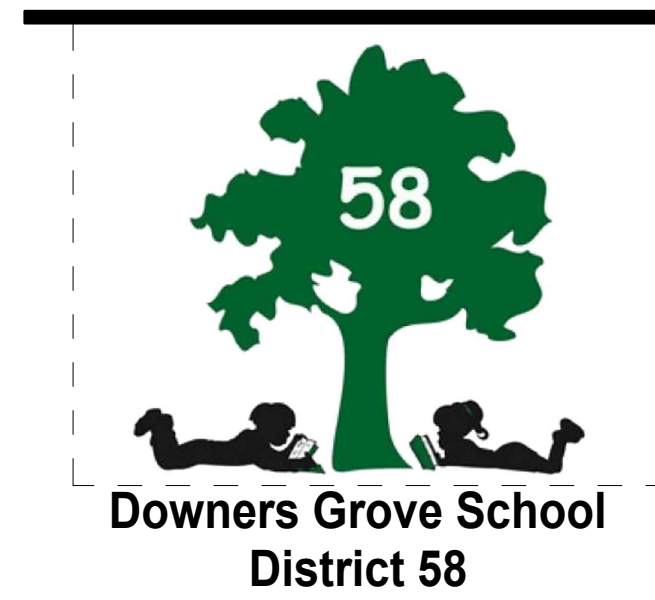

Wight & Company
wightco.com
2500 North Frontage Road
Darien, IL 60561
P 630.969.7000
F 630.969.7979

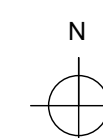
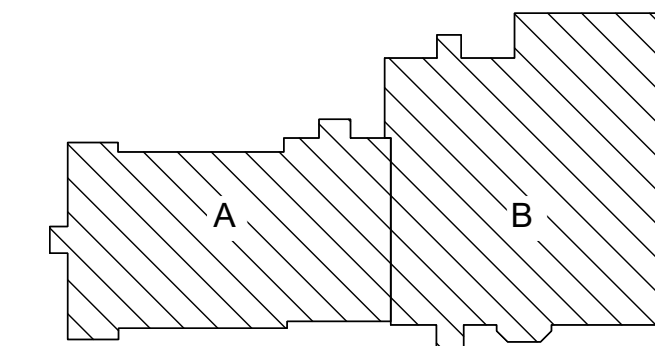

Table with 3 columns: REV, E-RATE RFP DESCRIPTION, 12/18/2023 DATE

WHITTIER ELEMENTARY SCHOOL

536 HILL STREET
DOWNERS GROVE, IL 60515

LEGEND AND GENERAL NOTES

Project Number: 220281
Drawn By: -
Sheet:



T0.0

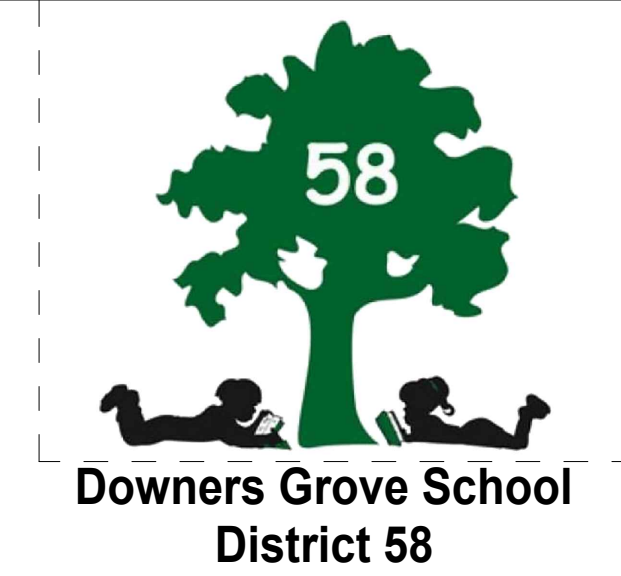

Wight & Company
 wightco.com
 2500 North Frontage Road
 Darien, IL 60561
 P 630.969.7000
 F 630.969.7979

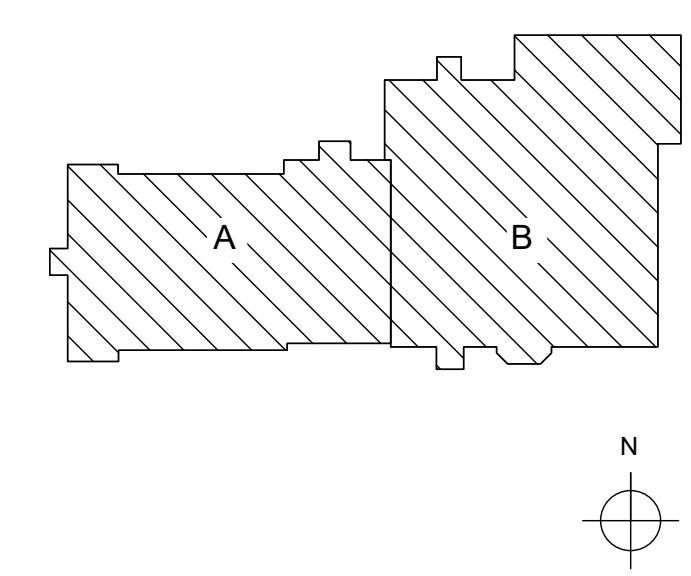

**NOT FOR
 CONSTRUCTION**

REV	E-RATE RFP DESCRIPTION	12/18/2023 DATE
-----	------------------------	-----------------

**WHITTIER
 ELEMENTARY
 SCHOOL**

536 HILL STREET
 DOWNERS GROVE, IL 60515

**TECHNOLOGY PLAN -
 BASEMENT AREA B**

Project Number:
 220281
 Drawn By:
 -
 Sheet:



T0.1

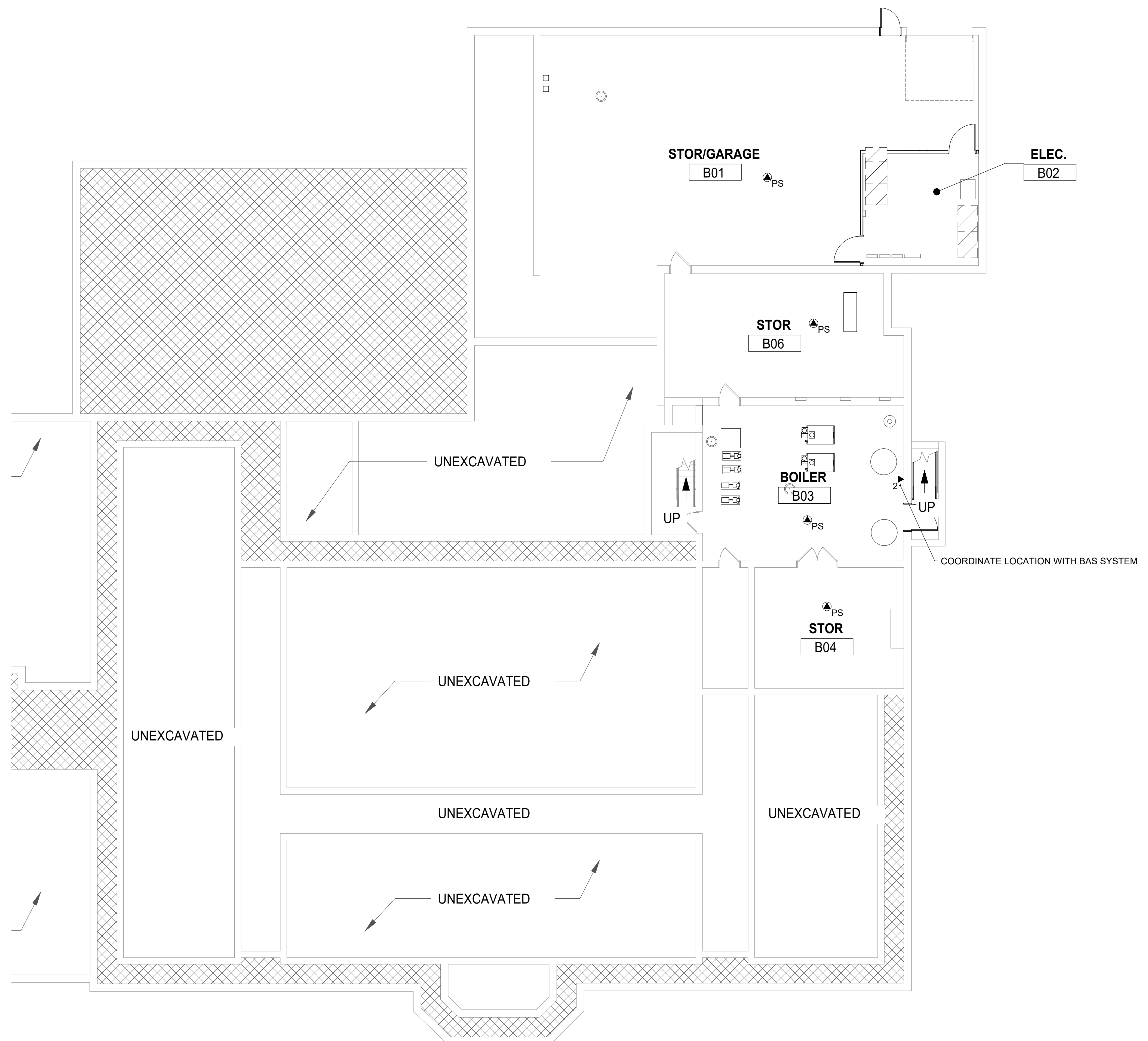



Wight

Wight & Company
wightco.com
2500 North Frontage Road
Darien, IL 60561
P 630.969.7000
F 630.969.7979

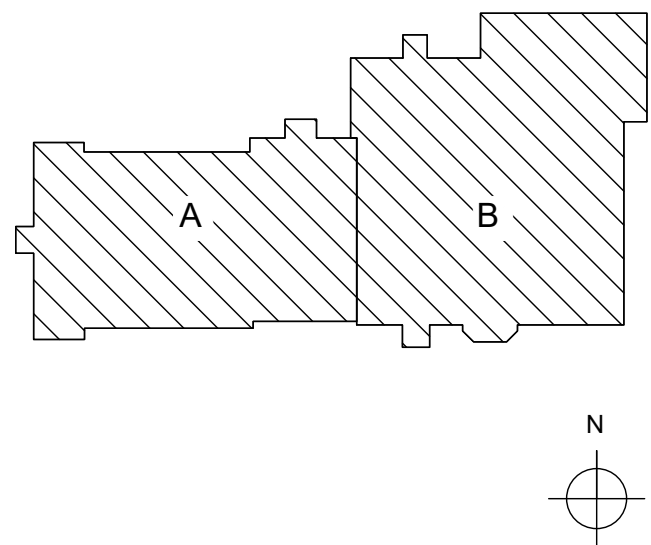

NOT FOR CONSTRUCTION

REV	E-RATE RFP DESCRIPTION	12/18/2023 DATE
-----	------------------------	-----------------

WHITTIER ELEMENTARY SCHOOL

536 HILL STREET
DOWNERS GROVE, IL 60515
TECHNOLOGY PLAN - AREA A

Project Number:
220281
Drawn By:
-
Sheet:



SENTINEL
2550 WARRENVILLE ROAD
DOWNERS GROVE, ILLINOIS 60515
630.769.4300
www.sentinel.com

T1.0

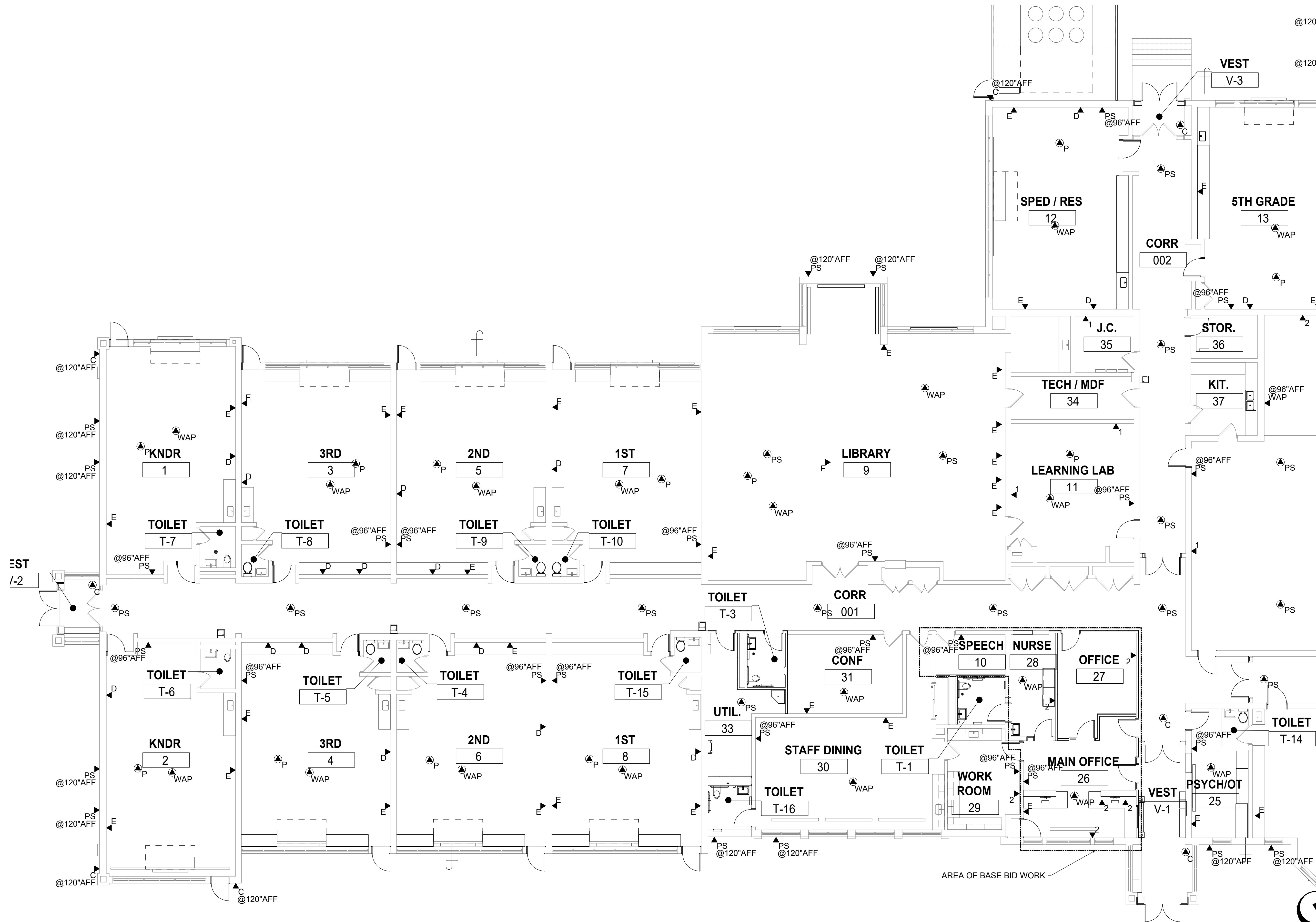



Wight

Wight & Company
 wightco.com
 2500 North Frontage Road
 Darien, IL 60561
 P 630.969.7000
 F 630.969.7979

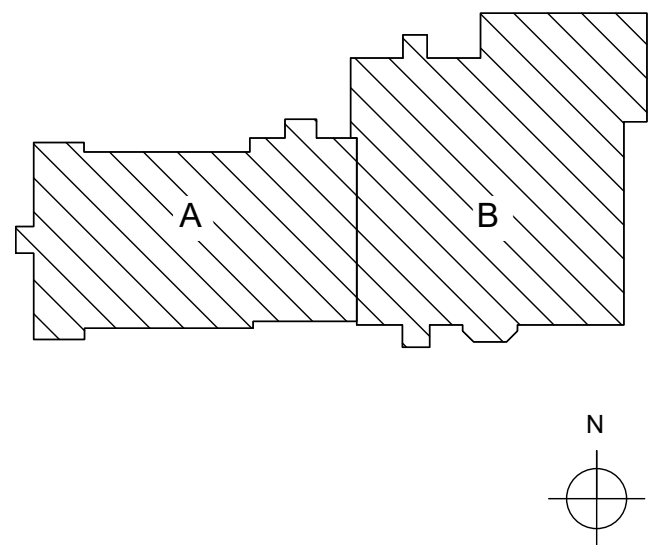

NOT FOR CONSTRUCTION

REV	E-RATE RFP DESCRIPTION	12/18/2023 DATE
-----	------------------------	-----------------

WHITTIER ELEMENTARY SCHOOL

536 HILL STREET
 DOWNERS GROVE, IL 60515
TECHNOLOGY PLAN - AREA B

Project Number:
 220281
 Drawn By:
 -
 Sheet:

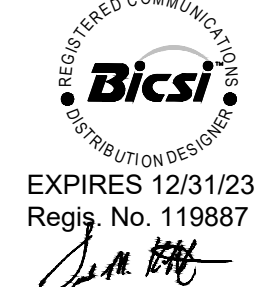

T1.1

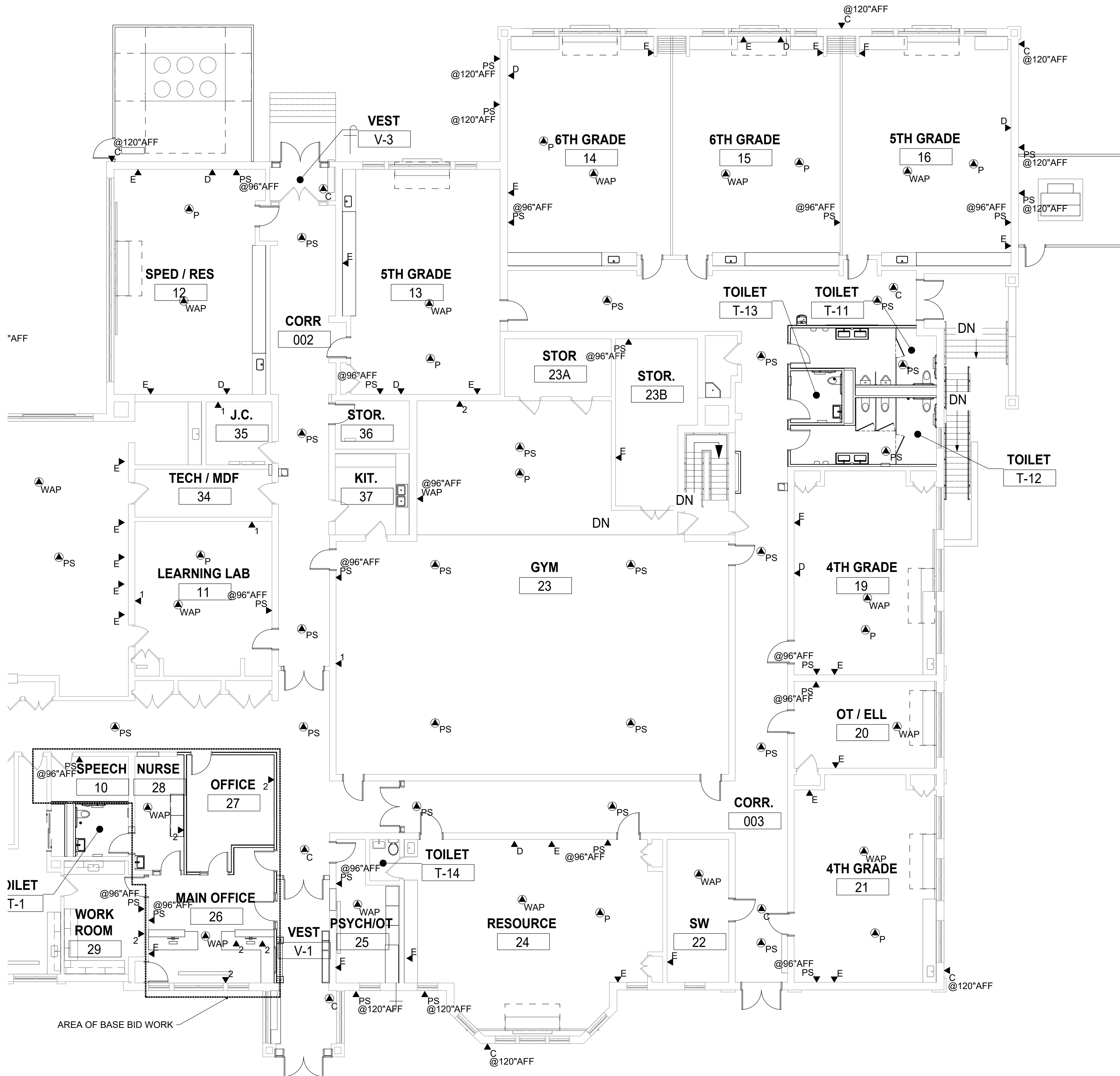

AREA OF BASE BID WORK

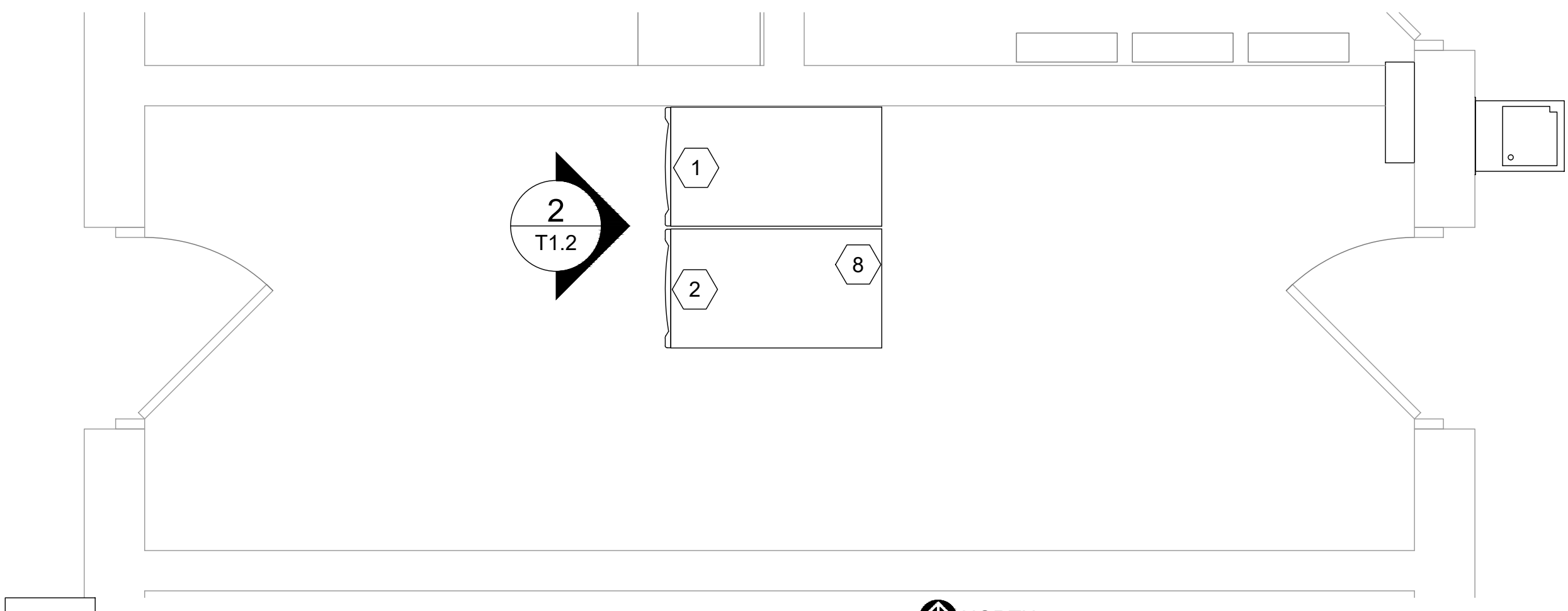

1 CABINET LAYOUT
PLAN VIEW
NORTH
1/2" = 1' - 0"

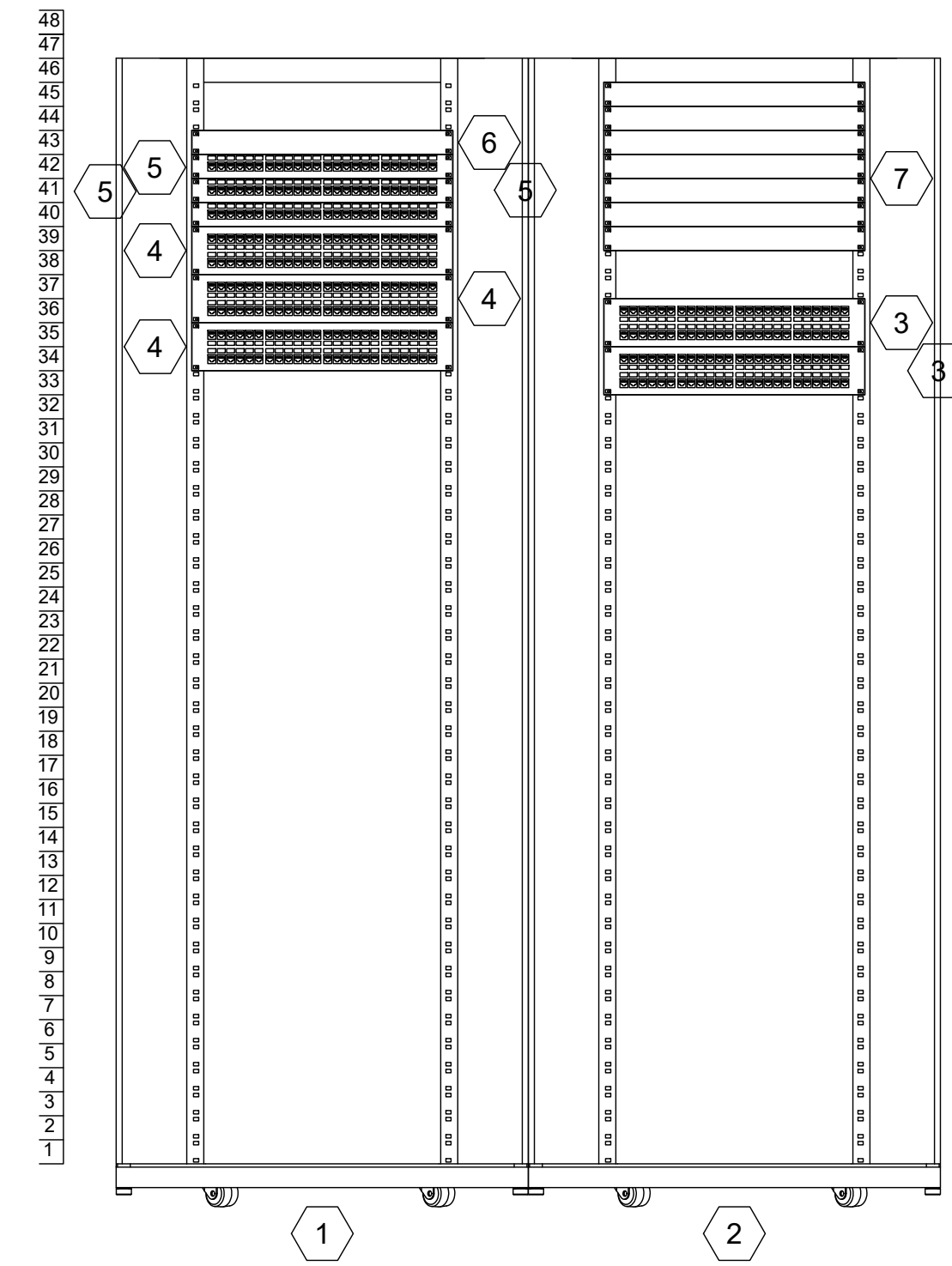

2 CABINET LAYOUT
ELEVATION VIEW - FRONT
1" = 1' - 0"

DRAWING KEYNOTES:

- 1 EXISTING TO REMAIN ENCLOSED EQUIPMENT CABINET.
- 2 CIC SUPPLIED AND INSTALLED ENCLOSED EQUIPMENT CABINET TO HOUSE THE PAGING SYSTEM COMPONENTS. CIC TO REMOVE EXISTING 2-POST RACK TO ALLOW FOR THE INSTALLATION OF THE PAGING CABINET.
- 3 CIC SUPPLIED AND INSTALLED CATEGORY 6 2U 48-PORT PATCH PANEL TO SUPPORT TERMINATION OF HORIZONTAL STATION CABLING FOR PAGING SYSTEM COMPONENTS. REFER TO SPECIFICATION FOR EXACT REQUIREMENTS.
- 4 CIC SUPPLIED AND INSTALLED CATEGORY 6 2U 48-PORT PATCH PANEL TO SUPPORT TERMINATION OF HORIZONTAL STATION CABLING. REFER TO SPECIFICATION FOR EXACT REQUIREMENTS.
- 5 CIC SUPPLIED AND INSTALLED CATEGORY 6A 1U 24-PORT PATCH PANEL TO SUPPORT WIRELESS ACCESS POINT CABLING CONNECTIVITY REQUIREMENTS. REFER TO SPECIFICATION FOR EXACT REQUIREMENTS.
- 6 CIC SUPPLIED AND INSTALLED 1U FIBER OPTIC TERMINATION SHELF TO SUPPORT TERMINATION OF FIBER BACKBONE CABLING. REFER TO SPECIFICATION FOR EXACT REQUIREMENTS.
- 7 CIC SUPPLIED AND INSTALLED PAGING SYSTEM COMPONENTS. REFER TO PAGING SYSTEM DETAILS DRAWING FOR EXACT REQUIREMENTS.
- 8 EC FURNISHED AND INSTALLED NEMA 5-20 QUAD RECEPTACLE MOUNTED IN THE REAR OF THE CABINET AT THE TOP. REFER TO E-SERIES DRAWINGS FOR EXACT REQUIREMENTS.

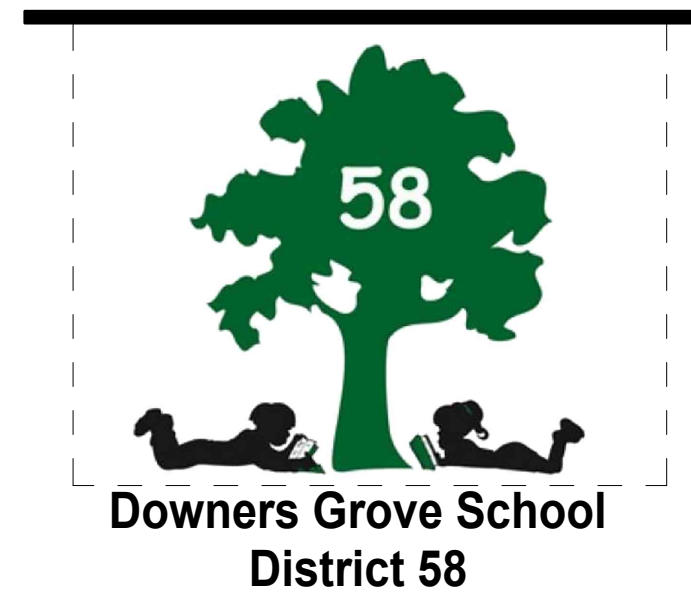

Wight & Company
wightco.com
2500 North Frontage Road
Darien, IL 60561
P 630.969.7000
F 630.969.7979

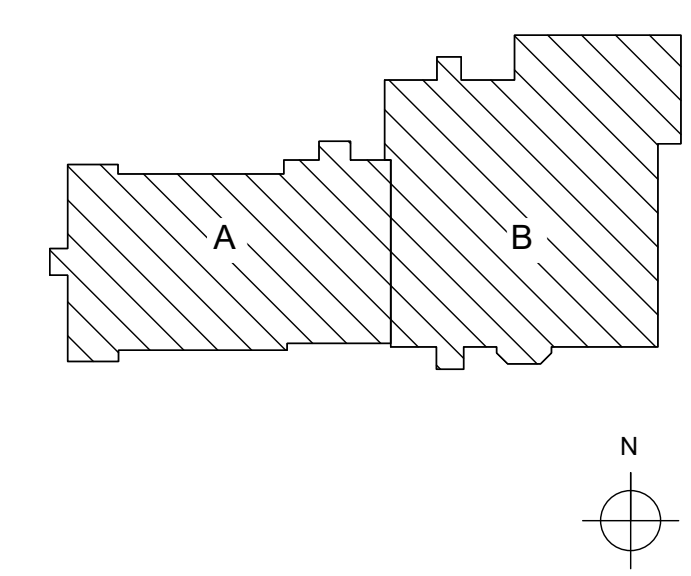

NOT FOR CONSTRUCTION

REV	E-RATE RFP DESCRIPTION	12/18/2023 DATE

WHITTIER ELEMENTARY SCHOOL

536 HILL STREET
DOWNERS GROVE, IL 60515
TECH/MDF 34 LAYOUT

SENTINEL
2550 WARRENVILLE ROAD
DOWNERS GROVE, ILLINOIS 60515
630.769.4300
www.sentinel.com

Project Number:
220281
Drawn By:
-
Sheet:



T1.2